

3700

SERIES

**Installation, Maintenance
& Operating Guide**

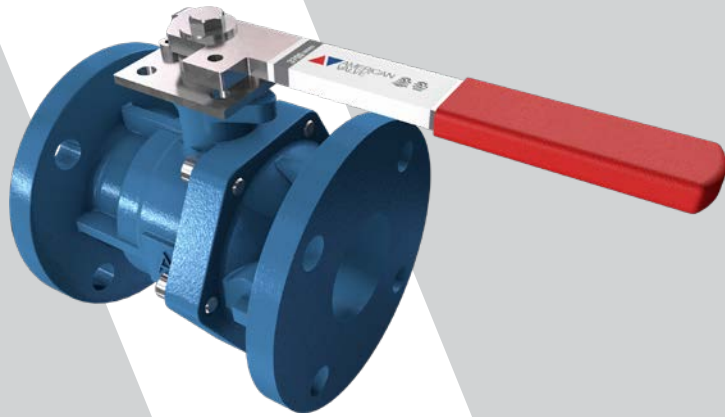

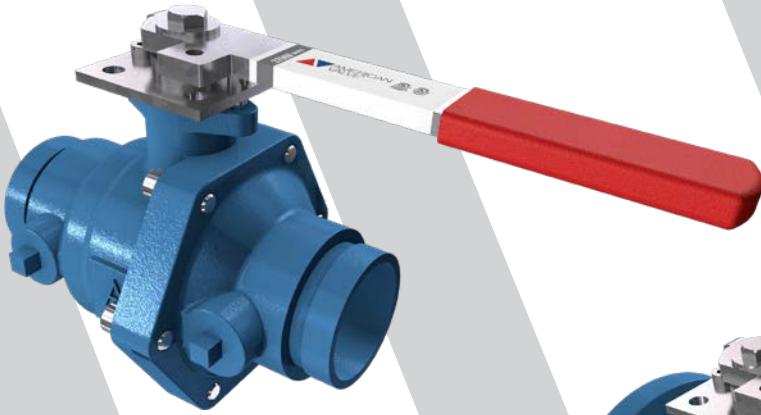

This document contains information pertaining to American Valve models 3700 and 3700V. American Valve reserves the right to change design features from time to time. Diagrams and descriptions in this guide may not exactly match your particular valve. If you are unsure of or do not completely understand a particular procedure, please consult the factory.

WARNING

For your personal safety and protection, it is important that you observe the following precautions before removing the valve from service or disassembling the valve.

1. Never adjust exterior screws or bolts while the valve is pressurized.
2. Keep hands and fingers out of valve. Actuated valves may close without warning, resulting in serious injury.
3. It is possible that residual media or pressure may be trapped inside the valve cavity. Ensure that the line and valve are properly depressurized and be aware of any residual harmful substances that may still be present.
4. To depressurize the valve:
 - A. Repeatedly open and close the valve to both drain the line and relieve any residual pressure in the valve cavity. Leave the valve in the open position.
 - B. Repeat this procedure once the valve is removed from the line and standing in the vertical position.
5. Exercise caution when handling a valve that has been used to control hazardous media. It is recommended that the valve and line be thoroughly flushed prior to removal and/or disassembly. Cycle the valve slowly while flushing to clear the cavity.

CAUTION

3700 Series Ball Valves feature a double “o”-ring stem with non-adjustable packing. Do not remove the stem retainer plate while the valve is under pressure.

1. Installation

1. Prior to installation, all valves and mating flanges should be inspected to ensure gasket surfaces are free from defects.
2. The valve and line should be free from dirt and debris, which can damage valve seats.
3. Piping should be checked for proper alignment and appropriate supports. Valves should never be used to align or brace improperly positioned pipe.
OVER-TIGHTENING FLANGE BOLTS TO COMPENSATE FOR EXCESS FLANGE SPACING COULD CAUSE THE VALVE BODY TO CRACK.
4. 3700 Series valves can be installed for flow in either direction. Visually inspect valve for foreign matter.
5. Install valve into pipeline and tighten flange bolts (3700) evenly according to recommendations of gasket manufacturer. For grooved-end products (3700V), refer to installation instructions provided with the coupling.
6. **DO NOT TIGHTEN OR OTHERWISE ADJUST BODY BOLTS. THEY ARE AT A PRE-SET EVENLY DISTRIBUTED TORQUE. OVERTIGHTENING OF ONE SIDE MAY CAUSE LEAKAGE, AND NECESSITATE BODY SEAL REPLACEMENT.**

2. Operation

1. The operation of 3700 Series ball valves consists of rotating the handle 90° (¼ turn) counterclockwise to open.
2. When the valve is in the open position, the handle is parallel to the pipeline.
3. When the valve is in the closed position, the handle is perpendicular to the pipeline.
4. Media which can solidify, crystallize, or polymerize should not be allowed to stand in ball valve cavities.

3. General Maintenance

1. Replacement seats and body seals are not available for 3700 Series valves. Consult the factory for all repair needs.
2. Body bolts are tightened to pre-set torques evenly distributed around the body. Any tightening or loosening of these bolts may result in leakage through the body gasket. Should this occur, consult the factory for repair options.
3. No special tools are needed for maintenance of American Valve 3700 Series valves.

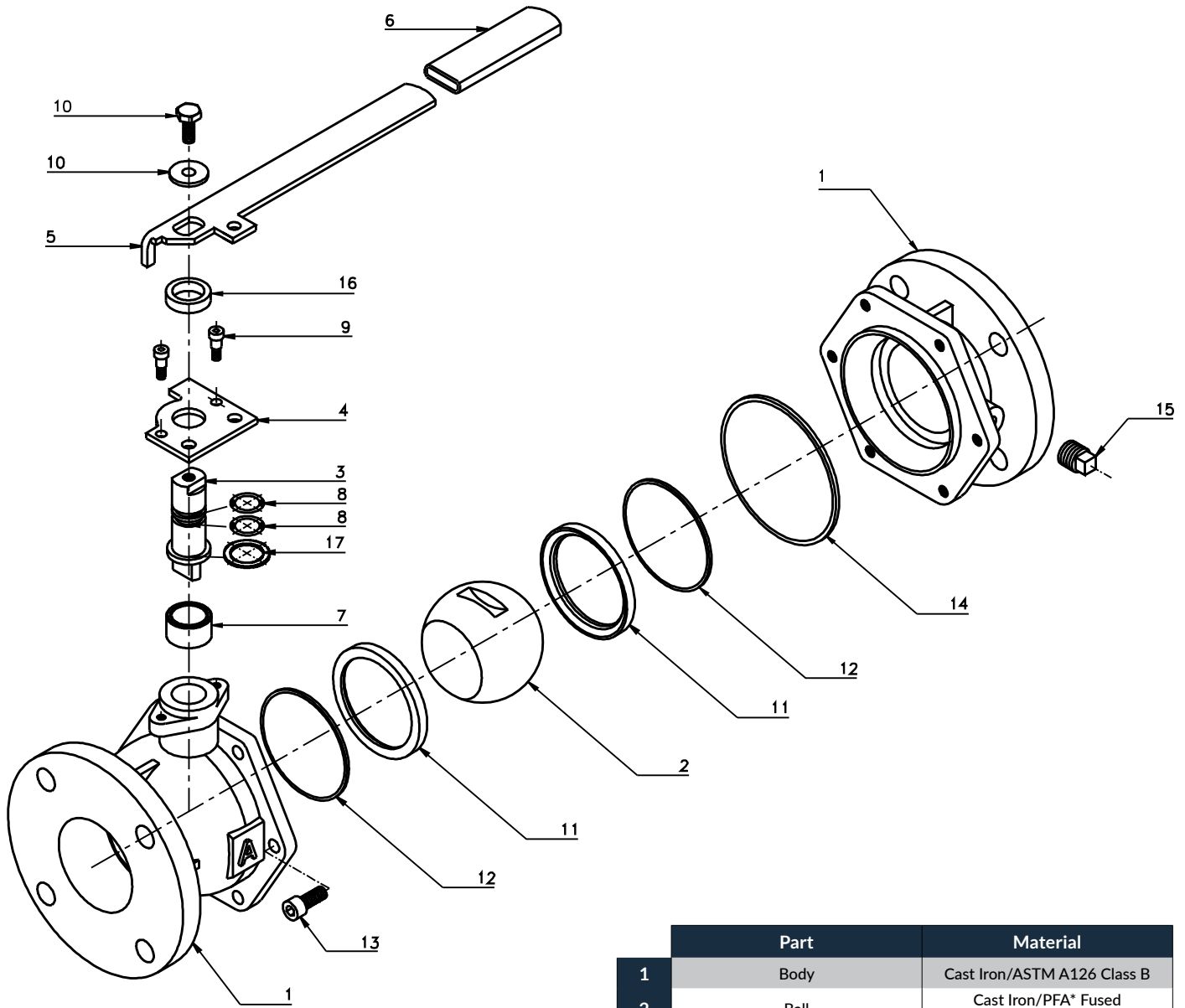

	Part	Material
1	Body	Cast Iron/ASTM A126 Class B
2	Ball	Cast Iron/PFA* Fused ASTM A48 Class-35
3	Stem	Stainless Steel
4	Stop Plate	Steel
5	Handle	Steel
6	Handle Grip	Vinyl Dipped Plastisol
7	Sleeve	Stainless Steel
8	Stem O-Ring	Nitrile Rubber (Buna-N)
9	Shoulder Screw	Steel
10	Stem Bolt/Washer	Steel
11	Seat Ring	Virgin PTFE
12	Back Seat O-Ring	Nitrile Rubber (Buna-N)
13	Socket Head Screw	Steel
14	Body Gasket	Nitrile Rubber (Buna-N)
15	Body Plug	2" - 4": Steel 6" - 8": Cast Iron
16	Collar	Steel

*PFA is an ingredient commonly branded as Teflon®



MODEL 3700V
CAST IRON GROOVED-END BALL VALVE

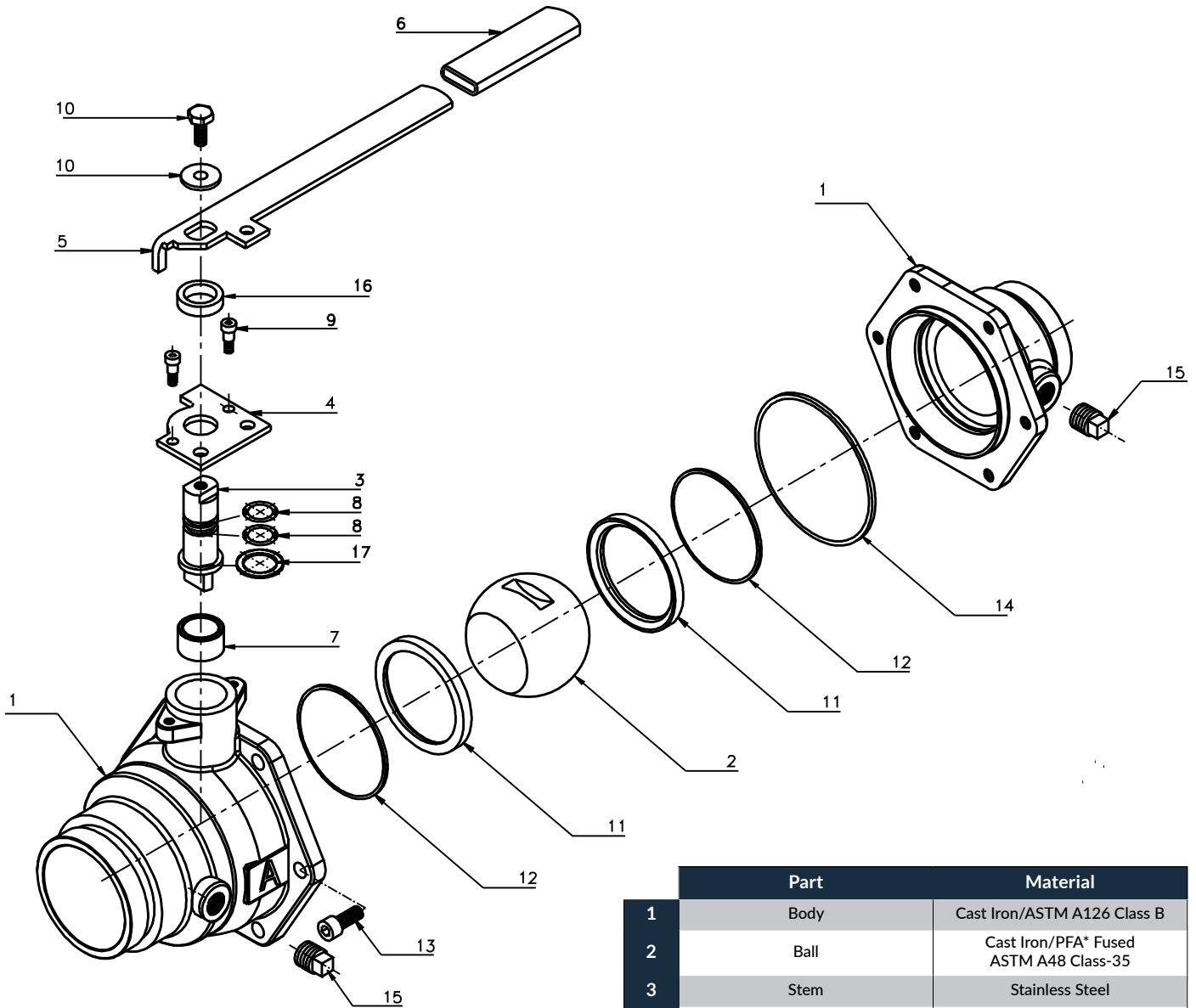

	Part	Material
1	Body	Cast Iron/ASTM A126 Class B
2	Ball	Cast Iron/PFA* Fused ASTM A48 Class-35
3	Stem	Stainless Steel
4	Stop Plate	Steel
5	Handle	Steel
6	Handle Grip	Vinyl Dipped Plastisol
7	Sleeve	Stainless Steel
8	Stem O-Ring	Nitrile Rubber (Buna-N)
9	Shoulder Screw	Steel
10	Stem Bolt/Washer	Steel
11	Seat	Virgin PTFE
12	Back Seat O-Ring	Nitrile Rubber (Buna-N)
13	Socket Head Screw	Steel
14	Body Gasket	Nitrile Rubber (Buna-N)
15	Body Plug	2" - 4": Steel 6": Cast Iron
16	Collar	Steel
17	Thrust Washer	PTFE
18	Body Cap	Cast Iron/A48 Class 30

*PFA is an ingredient commonly branded as Teflon®

AMERICAN VALVE
GREENSBORO, NC 27410
SALES@AMERICANVALVE.COM

IOM 3700 V1-6:19