

**United Security Products
Model AVD-45b
Automatic Voice Dialer**

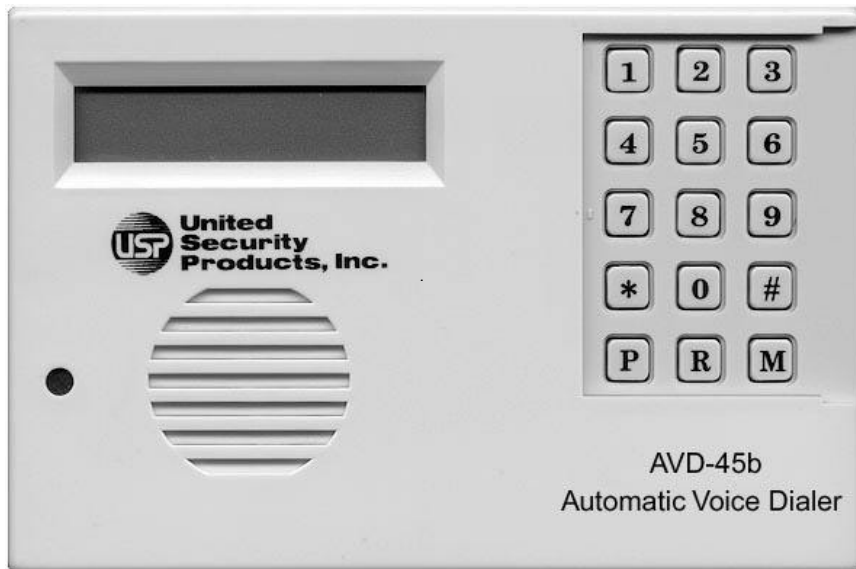

Patents
Pending

Installation and Instruction Manual

INTRODUCTION

Thank you for purchasing United Security Products Model AVD-45b, the single channel voice dialer that can be incorporated into hard wired or wireless security systems or used as a stand-alone unit. This versatile dialer can be easily expanded to operate in conjunction with an alarm, temperature or water level sensor, or any other sensor that can provide the appropriate trigger.

The AVD-45b is compatible with continuous, momentary, normally closed (NC) and normally open (NO) dry contact or voltage sensors. It can be programmed to sequentially dial any combination of four standard telephone, most cellular telephones, alpha/voice pagers and/or numeric pagers. The dialer features busy-line and no answer detection to ensure timely transmission of the recorded message of up to 16 seconds.

This manual describes how to set up, install and operate the AVD-45b. Please read the entire booklet before operating the dialer. For specific questions or problems, contact a USP Technical Service Representative at (858) 597-6677, Monday – Friday, 7:30 AM - 4:00 PM, Pacific Standard Time.

Package Contents

??Model AVD-45b Automatic Voice Dialer

??7-foot, 2-conductor jacket telephone cable with RJ11 plug attached

??7-foot jacketed, 4 conductor power/alarm cable

AVD-45b PANEL DISPLAY

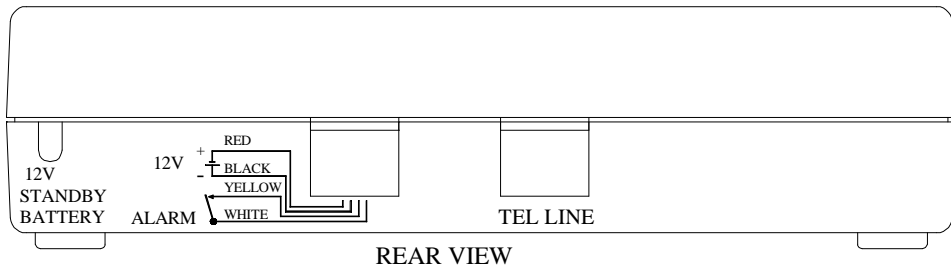

REAR VIEW

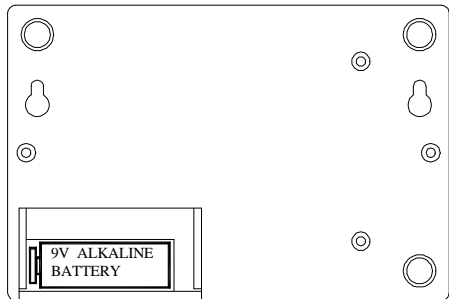

BACK VIEW

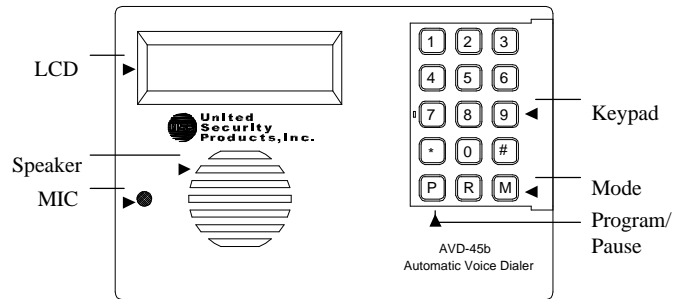

FRONT VIEW

N.C./N.O. DRY CONTACT ACTIVATION HOOKUP

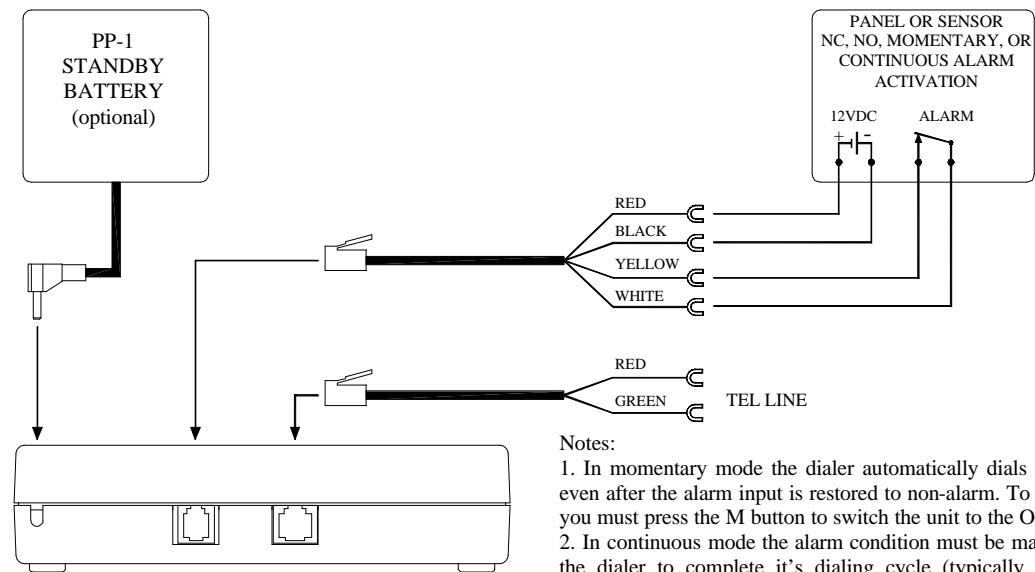

Notes:

1. In momentary mode the dialer automatically dials all numbers even after the alarm input is restored to non-alarm. To stop dialing you must press the M button to switch the unit to the OFF mode.
2. In continuous mode the alarm condition must be maintained for the dialer to complete its dialing cycle (typically 7 minutes). Dialing stops when the alarm input is restored to non-alarm or by pressing the M button.
3. Match the power cables colored wires to the corresponding outputs on the alarm panel. Do the same for the telephone cable.

Make sure unit is set to "OFF" prior to wiring and phone line hook-up.

VOLTAGE LEVEL ACTIVATION HOOKUP

WHEN THE ALARM OUTPUT VOLTAGE IS RELAY DRIVEN, YOU MUST ADD A 1K RESISTOR ACROSS ALARM OUTPUT TERMINALS. HOOK UP DIALER AS SHOWN BELOW.

Note: You may either program for momentary or continuous voltage activation. In continuous mode, make sure that the alarm condition is maintained for minimum 7 minutes to allow all numbers to be dialed. Pressing the M button immediately resets the dialer.

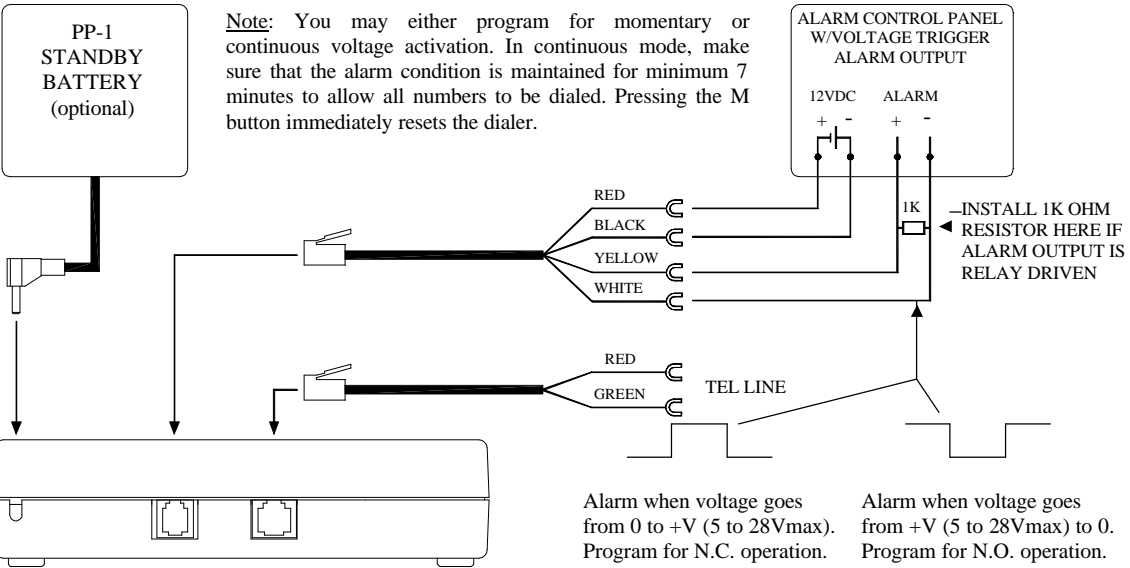
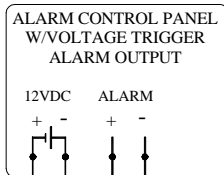

Alarm when voltage goes from 0 to +V (5 to 28Vmax). Program for N.C. operation.	Alarm when voltage goes from +V (5 to 28Vmax) to 0. Program for N.O. operation.
--	--

Match the power cables colored wires to the corresponding outputs on the alarm panel. Do the same for the telephone cable.

Make sure unit is set to "OFF" prior to wiring and phone line hook-up.

PROGRAMMING THE DIALER

IMPORTANT: Before operating the AVD-45b, make sure wiring is correct and power is set within specified limits. Recording and data recall can be performed without connection to a telephone line. We strongly recommend that final testing be performed under simulated alarm conditions, and that confirmation of transmission be obtained from the numbers dialed.

Model AVD-45b stores and dials up to 4 telephone numbers and/or pager numbers. Each number may contain up to 28 digits, including a maximum of 10 “pause” segments (a pause is 2 seconds long and counts as a digit) and an optional “pound” tone for pager dialing.

Once a connection is made, the dialer will deliver a recorded voice message of up to 16 seconds or a numeric code for pager messaging. The dialer will repeat the voice message two times per call, to ensure that a full message is delivered. If the phone number is busy or not answered within 8 rings, the AVD-45b will automatically dial the next programmed number.

Assuming an uninterrupted alarm (a minimum 7 minutes if programmed in continuous mode), the dialer will go through the numbers a second time, and call in an attempt to deliver the message twice to each programmed number. It will automatically call a pager # twice. If any numbers are busy or unanswered, the dialer will continue calling (up to 10 times per programmed number) in an attempt to deliver the voice message or until the alarm condition is terminated. In the TEST mode only, the respective location numbers and telephone numbers will appear in the LCD to show the calls are in process.

NOTE: If any numbers are used for alpha/voice pager designations that require operator assistance, the pager service should be notified, to ensure proper interpretation of the message.

PROGRAMMING THE DIALER

How to store phone numbers

Follow these directions to store up to 4 telephone numbers in the dialer's memory. Please remember that local ordinances may prohibit automatic dialing of police, fire departments and other emergency agencies.

The AVD-45b will call up to 4 numbers. This can be any combination of regular telephones, cellular telephones or pagers. The 4 numbers being called will be stored in locations 1-4. Any of locations 1-4 can store up to 28 digits and dial a telephone or pager. If dialing less than 4 numbers, simply leave the latter location(s) empty and the unit will automatically skip them.

To program telephone numbers:

1. Supply power to the AVD-45b.
2. The AVD-45b has four modes (PROGRAM, TEST, OPERATE, and OFF) indicated in the upper part of the LCD. Make sure the unit is in the "PROGRAM" mode. If it is not, press the MODE ("M") button to change modes.

To store "voice" telephone numbers in memory locations 1 through 4 (see p. 9 for pagers)

1. At the "PROGRAM: NUMBERS" prompt, press "1" (YES).
2. Press all the digits of the first number to be dialed. Check the LCD while programming to make sure the correct numbers are pressed.
3. After inputting the entire phone number (1 + area code if needed), press the PROGRAM/PAUSE ("P") button (momentarily), then the "1" key. This will store the number in location 1.
4. Repeat step 1, then press all the digits for the second number to be dialed. Check the LCD, press the PROGRAM/PAUSE ("P") button (momentarily), then the "2" key. This will store the number in location 2.
5. Repeat the process, if needed, for locations 3 and 4.

NOTE: Multiple pauses are used when dialing a pager or cell phone, in which case during the OPERATE mode the stored voice message will be played.

PROGRAMMING THE DIALER

Example 1: Store telephone number 1-800-555-1212 in Location 1.

Press: Program/Pause
(Press momentarily)

1 8 0 0 5 5 5 1 2 1 2 P 1

Example 2: Store telephone number 555-1212 in Location 2.

Press: Program/Pause
(Press momentarily)

5 5 5 1 2 1 2 P 2

Follow the steps above to store the desired numbers in Memory Locations 3 and 4.

Note: If you enter the wrong number or wish to change a programmed number, press the MODE (“M”) button until “PROGRAM: NUMBERS” prompt appears, enter “1” (YES) and enter the number then the location (see example 1 or 2 above).

To completely erase numbers already stored in memory locations:

1. Set dialer to “PROGRAM: NUMBERS” prompt.
2. Press “1” (YES).
3. Press PROGRAM/PAUSE (momentarily).
4. Press the number (1,2,3 or 4) for the memory location to be erased.

PROGRAMMING THE DIALER

To store a pager number and numeric code

1. With the dialer at the "PROGRAM: NUMBERS" prompt, press "1" (YES).
2. Enter all the digits of the pager number to be dialed. Check the LCD to insure the correct numbers are pressed.
3. After inputting the entire pager number (1 + area code if needed), press the PROGRAM/PAUSE ("P") button and hold it down for about 2 seconds. A "P" will appear in the LCD following the number. If more pauses are required, simply repeat the process by releasing the "P" button and pressing it again for 2 seconds. Up to 10 pauses are allowed.
4. After the pause sequence, input the numeric code to be delivered. This is the code that will be displayed on the pager. (Note: Some pager services require a "#" sign at the end of the numeric message for proper transmission. Also make sure that the total length of the number including pauses and "#" does not exceed 28 characters).
5. Finally, press the PROGRAM/PAUSE ("P") button (momentarily), then the "1" key. This will store the number, pauses and the numeric code in location 1.
6. Repeat step 1, then press all the digits for the second pager number to be dialed. Check the LCD, input pause(s), input the numeric code, then press the PROGRAM/PAUSE ("P") button (momentarily) and the "2" key. This will store the number in location 2.
7. Repeat the process, if needed, for locations 3 and 4.
8. You may store pager number and numeric code in any memory location (1-4).
9. When testing the pager operation, it is recommended that the AVD-45b be in the "OPERATE" mode, connected to a phone line and the input triggered.

NOTE: A pause counts as one digit. Up to 10 pauses are allowed.

PROGRAMMING THE DIALER

Example 1: Store pager number 555-1212 and numeric message 911 in Location 1.

Press:

Program/Pause (Hold for 2 seconds) Program/Pause (Press momentarily)

Example 2: Store pager number 1-800-555-1212 with access code 3 and numeric message 911 in Location 2.

Press:

Program/Pause (Hold for 2 seconds)

Access Code Enter if required by provider Program/Pause (Press momentarily)

Note: If you enter the wrong number or wish to change a programmed number, press the MODE button until “PROGRAM: NUMBERS” prompt appears, enter “1” (YES) and enter the number then the location (see example 1 or 2 above).

PROGRAMMING THE DIALER

Programming Tone/Pulse and PBX

1. Press the “M” key until “PROGRAM: NUMBERS” appears in the LCD, then press “2”.
2. Press “1” (YES) at the “PROGRAM: T-LINE” prompt.
3. Press “1” (TONE) for touch tone phone service.
Press “2” (PULSE) for pulse (rotary) phone service.
4. After selecting TONE or PULSE, the LCD will display “PROGRAM: PBX”.
5. Press “1” (ON) to set for PBX phone system, then enter the PBX digit 0-9 (This will allow the unit to dial the PBX digit, wait for a dial tone, then dial the stored number).
Press “2” (OFF) to set for regular phone system (Waits for a dial tone, then dials the stored number).

Programming Exit and Entry Delay

1. Press the “M” key until “PROGRAM: NUMBERS” appears in the LCD, then press “2” three times.
2. Press “1” (YES) at the “PROGRAM: CHANNEL” prompt.
3. Press “1” (ON) for a 60 second Exit delay (This provides a 60 second exit delay, after the AVD-45b is set in the “OPERATE” mode, before the unit will react to a sensor trip, allowing time to exit).
Press “2” (OFF) for no Exit delay (This will allow the unit, when set in the “OPERATE” mode, to react immediately to a sensor trip).
4. After selecting the Exit delay, the LCD should display “ENTRY DELAY”.
5. Press “1” (ON) for a 20 second Entry delay (This provides a 20 second entrance delay, after any exit delay time has elapsed, before the unit will react to a sensor trip, allowing time to shut off).
6. Press “2” (OFF) for no Entry delay (This will allow the unit to react immediately to a sensor trip, after any exit delay has elapsed).

NOTE: When using the AVD-45b with an alarm panel that already has Exit/Entry delays programmed, EXIT and ENTRY should be programmed for “OFF” unless an additional delay is needed.

PROGRAMMING THE DIALER

- 7 Immediately after selecting Exit and Entry delays, the LCD displays input options; N.O./N.C. for either normally open or normally closed contact operation. Select by entering 1 or 2, depending on the type alarm contact used; select N.O. when input is shorted or N.C. when input opens during an alarm.
- 8 Next, select either 1(MOM) or 2(CONT) for momentary or continuous activation. Note: A momentary alarm must be 0.5 seconds or longer for the dialer to dial all numbers in sequence, including all attempts to re-dial. In the continuous mode the dialer stops dialing immediately when the input is restored to a non-alarm state. Therefore, an alarm condition in the CONT mode must last long enough (7 minutes or longer) to allow all numbers to be properly dialed.

How to record outgoing voice message

An outgoing message (OGM) of up to 16 seconds may be programmed into the AVD-45b. Once recorded, this message will be repeated during activation 2 times, in sequence (starting with Location 1), to each number designation. For best results, the OGM should be written down, practiced and timed before recording.

1. Press the “M” key until “PROGRAM: NUMBERS” appears in the LCD, then press “2” twice.
2. Press “1” at the “PROGRAM: OGM” prompt.
3. Locate the microphone on the lower left corner of the AVD-45b. For best results when recording, speak about 12 inches from the microphone in a clear and normal voice.
4. Press “*” key to initiate the recording process. “RECORDING” will appear in the LCD when recording. The “*” key must be held down for the entire time of recording.
5. When the “*” key is released the message will be stored. Once the 16 seconds have elapsed, “DONE” will appear in the LCD.
6. If you wish to change the OGM, repeat the preceding steps. The new OGM will automatically replace the previous message.

PROGRAMMING THE DIALER

To verify telephone numbers and OGM without phone line connection

Follow these directions to ensure the correct telephone numbers have been properly stored and the recorded message satisfactory.

1. Press the “M” key until “TEST: T-LINE” appears.
2. Press “1” (YES). The LCD will display the T-LINE configuration.
3. Press “1” (YES) at the “TEST: CHANNEL” prompt. The LCD will display the Delay configuration, then the number stored in Location 1 followed by either the OGM or pager code.
4. This process will be repeated for each stored Location. Any empty Location will be skipped.
5. Press the “M” key three times to return to the program mode.

To verify telephone numbers and OGM with phone line connection

NOTE: A complete test should be performed in the “OPERATE” mode to ensure proper operation.

1. Before conducting an actual test under “OPERATE” mode, contact each of the designated emergency numbers (Locations 1 through 4) to advise people that you are conducting a test. After the test, verify that they received the message.
2. Apply power to the unit.
3. Press the “M” key until “OFF” appears in the LCD.
4. Connect the AVD-45b to an active phone line.
5. Make sure the sensor is in a non-alarm condition.
6. Press “M” until “OPERATE” appears in the LCD.
7. Trigger the sensor to simulate an alarm condition. If there are any delays programmed, the AVD-45b will wait until they elapse before activating and dialing.

- 8. The AVD-45b will sequentially dial the programmed Locations (1-4). If there is no number stored in a location, it will be skipped. The OGM will be delivered when the AVD-45b receives an answer. (The OGM will not be played through the speaker.) For pager numbers, the pager code will be transmitted instead of an OGM.
- 9. The AVD-45b will automatically go through the next programmed Location repeating the same process.

The AVD-45b is now ready for operation.

Utilizing the EEPROM and CPU memory cell components, the AVD-45b will retain its' memory in the event of a power loss. The internal 9-volt alkaline battery will provide stand by power for approximately 4 hours of operation. If more battery backup is needed, an optional rechargeable power pack (USP part# PP-1 or PB12P Combination AC Adaptor/Rechargeable battery) is available and plugs into the AVD-45b, providing up to 24 hours of stand by power.

IMPORTANT INFORMATION

LOCATION

Place the dialer on a flat level surface or mount the unit on the wall, away from extreme cold or heat, direct sunlight, excessive humidity and away from equipment that generates a strong magnetic field. Avoid placing near large metal objects and areas that produce smoke, dust or mechanical vibrations.

CARE

Clean the housing with a soft cloth lightly moistened with water or mild detergent solution. Never use solvents such as alcohol or thinner. Do not allow liquids to spill into the unit.

OPTIONAL BACKUP

To ensure continuous operation during power outages, hookup to a 12VDC backup battery pack as recommended.

CAUTION

Do not use the dialer if a gas leak is suspected or during lightning.

PROBLEMS

If liquid or a foreign object penetrates the unit, disconnect it immediately and contact your installer or other qualified technician.

Before calling USP, please make sure ...

?? You have read this manual and understood how to operate the dialer.

?? Your phone line is working.

?? You check out the entire system.

If you still have questions or concerns, call USP Technical Service Department between the hours of 7:30 AM and 4:00 PM, PST, Monday through Friday.

IMPORTANT INFORMATION

Federal Communications Commission Radio And Television Interference Statement For A Class 'B' Device

This equipment generates and uses radio frequency energy and if not installed and used properly, that is, in strict accordance with the manufacturer's instructions, may cause interference to radio and television reception. It has been type tested and found to comply with the limits for a Class 'B' computing device in accordance with the specifications in Subpart B of FCC Rules and Regulations (as outlined in the Code of Federal Regulation, Title 47), which are designed to provide reasonable protection against such interference in a residential installation.

User Instructions

If this equipment does cause interference to radio or television reception, which can be determined by turning the equipment off, then on, the user is encouraged to try to correct the interference by one or more of the following measures:

- ??Reorient or relocate radio or television.
- ??Increase the separation between the equipment and receiver.
- ??Connect the equipment into a different outlet so that the equipment and receiver are on different branch circuits.
- ??Consult the dealer or an experienced radio/TV technician for help.

Changes or modifications not expressly approved by United Security Products, Inc. will void the warranty.

FEATURES SUMMARIZED

- ??Non volatile (EEPROM) memory for voice message and phone numbers
- ??Calls up to 4 phone numbers, any combination of telephones or pagers
- ??Sends up to 16 second voice message to telephones or numeric code to pagers
- ??Record your own message in any language
- ??Easily change message and phone numbers without a programmer
- ??Voice chip technology (no tape required)
- ??Ability to program up to 10 (2-second) pauses and pound (#) for pager dialing
- ??Returns to call unanswered numbers
- ??2 X 16 character LCD window
- ??Internal playback speaker for voice message
- ??Programmable Exit and Entry delay
- ??Internal 9V battery backup
- ??Works with PBX or regular phone system
- ??Tone or Pulse dialing
- ??NC, NO, momentary, continuous or voltage activation
- ??Internal protection against transient overload conditions

DIALER ACCESSORIES

Consult factory for availability and pricing

24V APPLICATION: AVD-45b/F

- For this option the dialer is configured to operate at 24VDC to 32VDC max. All other specifications apply.
- **AC-2 AC/DC ADAPTOR (500mA)**
Plugs into regular 110VAC outlet to provide the dialer with the required 12VDC primary power.
- **PP-1 BACKUP BATTERY PACK**
Plugs into 12V Standby Battery jack. Built-in rechargeable battery for up to 24 hours of uninterrupted standby.
- **PB12P Combination AC Adaptor/Rechargeable battery for extended operation for up to 24 hours of uninterrupted standby.**

**FCC PART 68
INFORMATION SUPPLIED TO THE USER**

This equipment complies with Part 68 of the FCC Rules. The FCC Part 68 Label is located on the bottom of the enclosure. It contains the FCC Registration Number for this equipment. If requested, this information must be provided to your telephone company. The BEN is useful to determine the quantity of devices you may connect to your telephone line and still have those entire devices ring when your telephone number is called. In most, but not all areas, the sum of the RENs of all devices connected to one line should not exceed five (5.0). To be certain of the number of devices you may connect to your line, as determined by the BEN, you should contact your local telephone company to determine the maximum BEN for your calling area. Connection to the telephone network should be made by using standard modular telephone jacks, type RJ11C. The RJ11C plug and/or jacks used must comply with FCC Part 68 rules. If this telephone equipment causes harm to the telephone network, the telephone company will notify you in advance that temporary discontinuance of service may be required. But if advance notice isn't practical, the telephone company will notify the customer as soon as possible. Also, you will be advised of your right to file a complaint with the FCC if you believe it is necessary. The telephone company may make changes in its facilities, equipment, operations or procedures that could affect the proper functioning of your equipment. If they do, you will be notified in advance in order for you to make necessary modifications to maintain uninterrupted service. This equipment may not be used on coin service provided by the telephone company. Connection to party lines is subject to state tariffs. If trouble is experienced with this unit, please contact customer service at the address and phone listed below. **DO NOT DISASSEMBLE THIS EQUIPMENT. IT does not contain any user serviceable components.**

Attn: CUSTOMER SERVICE DEPT. United Security Products *13250 Gregg St.,
Ste. B, Poway, CA 92064 Ph: 858-413-0149

Model AVD-45b Automatic Voice/Pager Dialer

SPECIFICATIONS:

Power requirements:	9-18VDC
Current draw (OPERATE mode - Stand By):	28mA
Current draw (OPERATE mode - Alarm):	100mA
Activation:	1. NO or NC, Momentary or Continuous dry contact Activation. 2. Voltage Activation: 0 to +V (NC operation) or +V to 0 (NO operation). Note: +V limited from 5 to 28VDC
Phone numbers stored:	Up to 4
Max. digits/phone number:	28 (including pauses)
Programmable pauses (2 sec./pause):	up to 10 for pager dialing (each pause counts as 1 digit)
Operating temperature range:	-18 to 55 C (0 to 130 deg F)
Dimensions (inches):	6.0 x 4.0 x 1.5
Weight (ounces):	10 oz.
Mounting:	Wall or Flat Surface
Case Material:	ABS
Color:	White
Warranty:	1 year

Note: Design and specifications subject to change without notice.



13250 Gregg St, Ste. B, Poway, CA 92064

Ph: 858-413-0149 Fax: 858-413-0124 e-mail: usp@unitedsecurity.com www.unitedsecurity.com