

# Airtrol<sup>®</sup> System

- The time proven method of air control for hydronic systems
- A complete line of air control components
- Guaranteed to prevent the accumulation of air in heating and cooling units
- Twenty year product warranty

# A PROVEN CONCEPT FOR AIR CONTROL

Hydronics is the science of heating and cooling with circulated water. The ability to transfer large quantities of heat to or from an area in sealed piping systems makes hydronics an excellent choice for all types of construction.

Basically the techniques of hydronic design are quite simple. Adherence to just a few basic fundamentals will enable a designer to produce an efficient and economical heating or cooling system for a wide range of applications. One of the most important of these fundamentals is positive air control.

Efficient circulating water (or anti-freeze) systems must be completely free of air for proper operation. Free air in piping circuits causes reduced or blocked circulation as well as noisy operation. Free air also has damaging effects on various system components. Yet, air, properly controlled, can offer both the expansion space and pressurization needs of a closed system. A Bell & Gossett Design Manual on Air Control reviews this subject in detail.

The Bell & Gossett Airtrol System is based upon this same concept of air control for closed hydronic systems of all sizes. The Airtrol System consists of three basic components:

1. The Rolairtrol Air Separator, serves to separate air bubbles from the system water before they can enter the system.
2. The compression tank or tanks; where all free air should be confined.
3. The Airtrol Tank Fitting serves to help confine air in the Compression tank, reduces gravity circulation which thru lower tank temperature reduces tank size and helps establish the correct initial air content in the tank when filling a system.

The Airtrol System has been in use on hydronic systems for over forty years and as a result of its complete success on all types and sizes of systems, is offered with both a product and a performance guarantee when installed in accordance with the published Bell & Gossett design data. Every hydronic system requires air control—guaranteed with the B&G Airtrol System.

*A Bell & Gossett Design Manual on Air Control reviews this subject in detail.*

## **AIRTROL SYSTEM PERFORMANCE GUARANTEE**

*The Bell and Gossett Airtrol System consists of three basic components:*

*The Airtrol Boiler Fitting or Inline or Rolairtrol Air Separator, the Airtrol Tank Fitting and the Bell and Gossett Compression Tank.*

*The Bell and Gossett Airtrol System is guaranteed to prevent the accumulation of air in heating and cooling units and prevent noises caused by entrained air in piping. In case of failure of any Bell and Gossett Airtrol System (within the USA) to operate correctly, when installed and operated in accordance with our published instructions on an air-tight system, we will provide, free of charge, the services of a factory trained engineer who will supervise steps necessary to provide satisfactory results.*

## **AIRTROL PRODUCT WARRANTY**

*The Airtrol Tank Fitting, Airtrol Boiler Fitting, Inline Air Separator, Rolairtrol Air Separator and Compression Tank are guaranteed for 20 years from date of installation against defects in material and workmanship. Labor charges for replacement are not allowed nor shall Bell and Gossett be liable for any special, indirect or consequential damages. ALL IMPLIED WARRANTIES OF MERCHANTABILITY AND FITNESS FOR A PARTICULAR PURPOSE ARE HEREBY DISCLAIMED.*

# A COMPLETE LINE OF AIR CONTROL PRODUCTS

## AIRTROL® TANK FITTINGS

Directs free air to the compression tank. Restricts thermal circulation to boiler. Establishes initial tank air level. Allows compression tank size reduction.

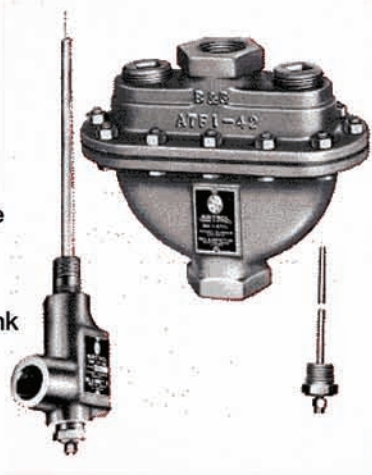

## IN-LINE® AIRTROL FITTINGS

Available in only straight pipe connections; cast iron construction 1" - 3" pipe sizes.



## ROLAIRTROL® AIR SEPARATOR

Unique design with tangential nozzles, separates air via centrifugal force. Highly efficient units include pump suction strainer option. Sizes from 3" to 24" are available.

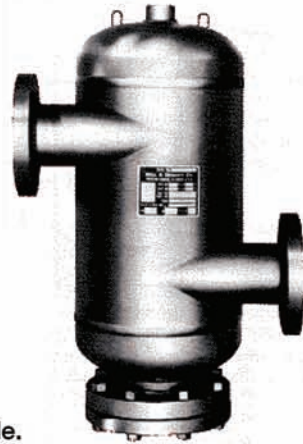

## THE BELL & GOSSETT COMPRESSION TANK

Air-tight, ASME construction. Available in plain steel or painted. Sizes from 15 to 505 gallons. Gauge glass tapplings are standard. Always use with B&G Airtrol Tank Fittings.



## IAS IN-LINE® AIRTROL FITTINGS

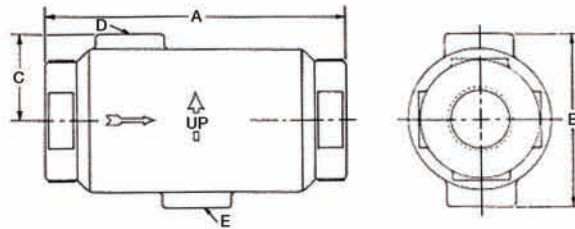
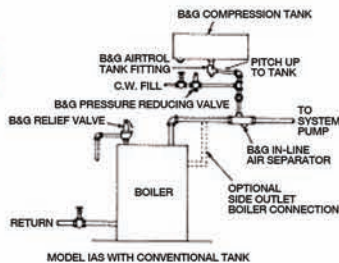

Model No.	Size Inches NPT	Max. Flow GPM	Dimensions										Approx. Shpg. Wgt. Lbs.	Kg
			A		B		C		D		E			
			IN	mm	IN	mm	IN	mm	IN	mm	IN	mm		
IAS-1	1	15											3½	1.7
IAS-1½	1½	25	6½	152	3½	89	1½	45					3½	1.6
IAS-1½	1½	35											8½	3.9
IAS-2	2	50	8½	203	4½	114	2½	57	¾	20	½	13	7½	3.4
IAS-2½	2½	75											23	10.5
IAS-3	3	125	10½	254	6½	162	3¾	81					21½	9.8

# AIRTROL<sup>®</sup> TANK FITTINGS

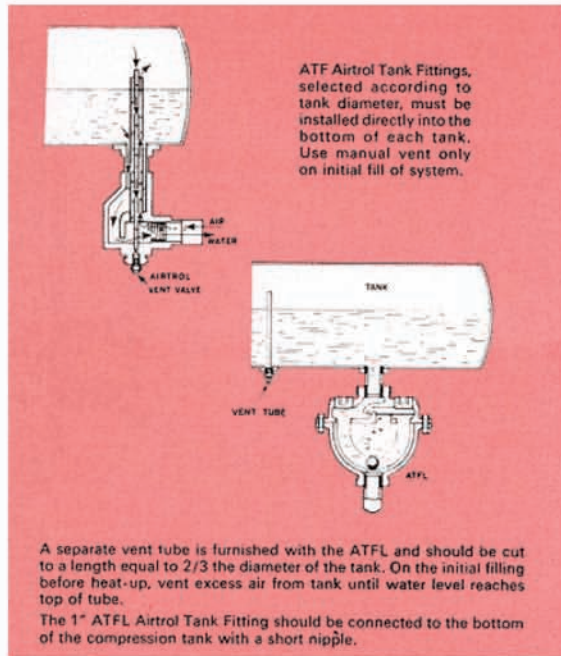
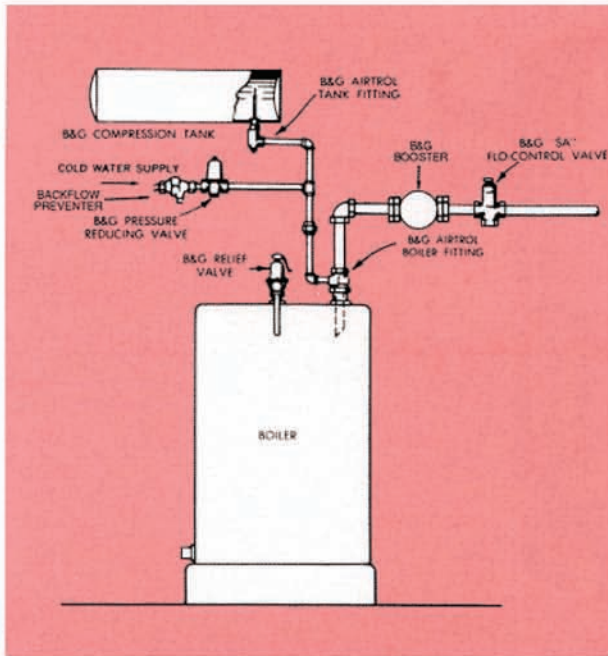

For proper operation, the air cushion Compression Tank(s) should be the only air space within a closed hydronic system. This air cushion can then provide adequate pressurization for all fluctuations of water volume.

However, because air can be absorbed in water, some means of restricting the flow of cooler water (gravity circulation) from the tank into the system is needed without restricting passage of free air into the tank. Compression tank size can be reduced considerably by reducing vapor pressure if this can be achieved.

B&G Airtrol Tank Fittings fill this need. The cross section of the ATF fitting illustrates how air bubbles can rise directly into the tank, but water flow is restricted by a baffle or trap. ATF fittings are available for tanks up to and including 24" diameter.

For tanks of 100 gallons and larger, the 1" ATFL fitting is recommended. As illustrated, air bubbles form an air trap at the bridge and rise unobstructed into the tank. Water will not circulate across this air trap so must return to the system via the "U" tube. A small differential in pressure between the system and the tank will move the non-ferrous ball past the small port, permitting tank water to return to the system. A large difference in pressure will force the ball to either end of the tube, thus permitting full flow through the tube to or from the system.

Both the ATF and ATFL are also equipped to help establish the correct initial air level in the compression tank when filling a system. After a system has been thoroughly cleaned and flushed, it is then filled with water. In the process of filling, air will be trapped in the compression tank. Usually too much air is trapped within the tank, since additional air will be collected in the process of heating and de-aerating the system water. A manual air vent is furnished on the ATF, separately with the ATFL, which will permit excess air to be released from the tank prior to heat-up of the system.

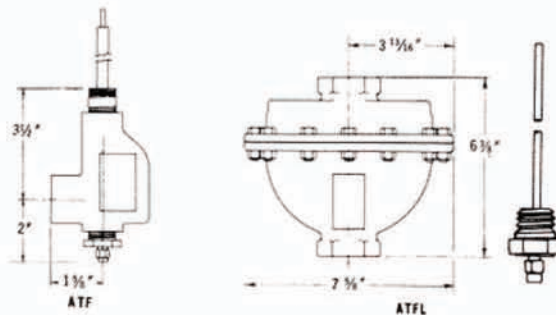

Catalog Number	Diameter of Compression Tank	Tank Connection	Boiler Connection
ATF- 9	9"	1/2" Male	3/4" Female
ATF-12	12", 13" or 14"	1/2" Male	3/4" Female
ATF-16	16"-18"	1/2" Male	3/4" Female
ATF-20	20"-22"	1/2" Male	3/4" Female
ATF-24	24"	1/2" Male	3/4" Female
ATFL	For tanks 100 gals. and larger.	1" Female	1" Female

Maximum Design Limitations 175 psig @ 250°F

The Airtrol System is designed to maintain the right amount of air in the compression tank; therefore it is important to match the Airtrol Tank Fitting as closely as possible to the diameter of the tank being used.

# THE ROLAIRTROL® AIR SEPARATOR

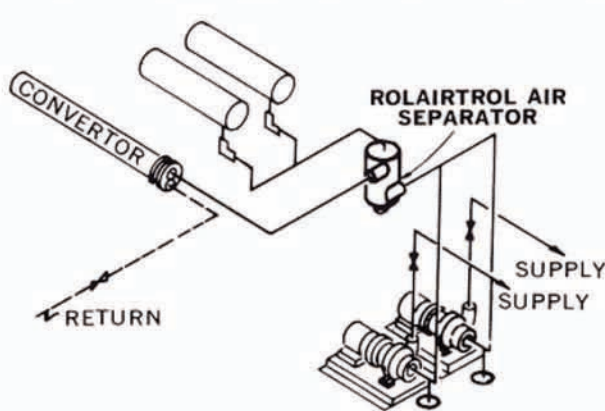
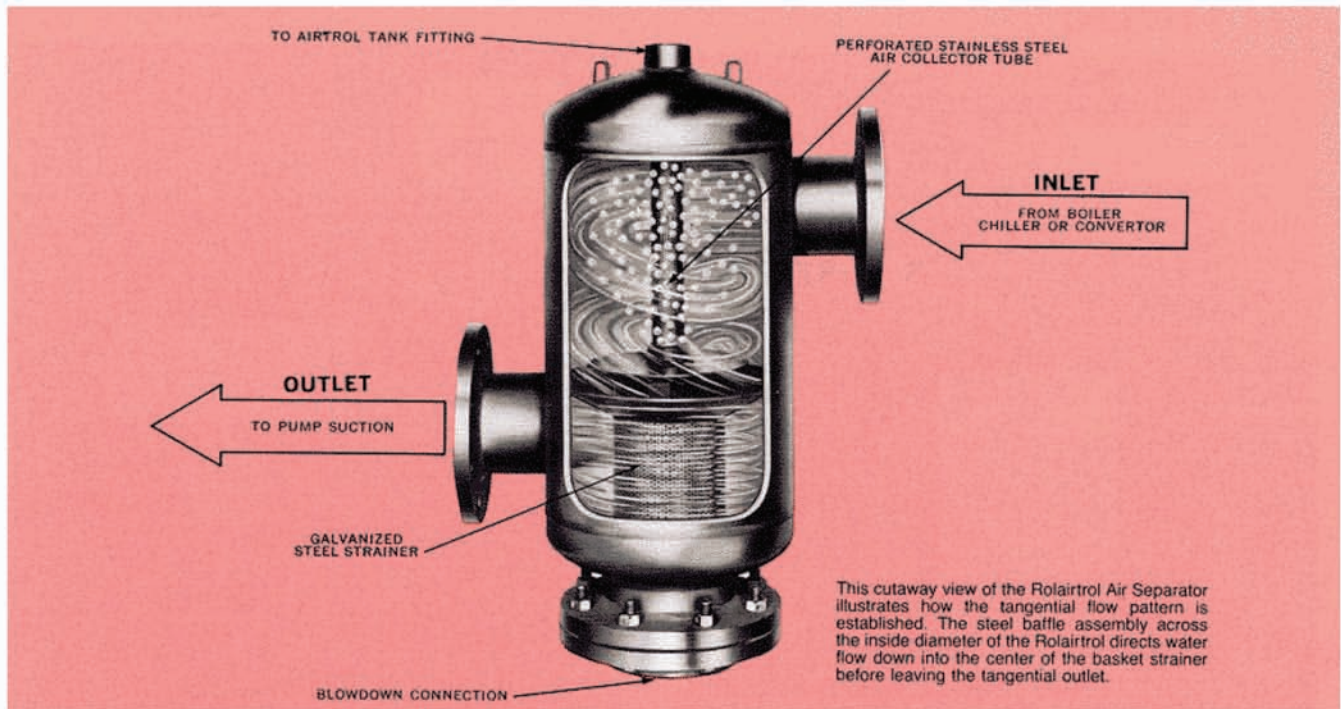

**CONVERTOR SYSTEM WITH ZONE PUMPS**

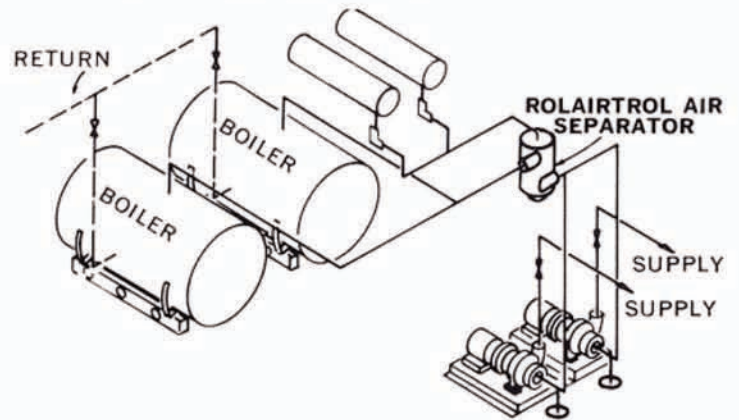

**MULTIPLE BOILER WITH ZONE PUMPS**

Typical installation for both boiler and convertor applications shows Rolairtrol Air Separator installed so that system strainer is always accessible for cleaning. Note system pump always operates away from Rolairtrol Air Separator.

The Rolairtrol Air Separator provides effective separation of free air from the system fluid thru its unique design and tangential nozzles which work together to create a low velocity vortex around the stainless steel air collector tube. The action of centrifugal forces causes heavier bubble free water to move to the outside while the lighter air entrained water moves into the low velocity area at the center. Physical size is

reduced considerably over conventional low velocity separators. Models with removable system strainer require installation so that the strainer is always accessible for cleaning. Strainers should always be removed and cleaned after 24 hours and 30 days of system operation. Any system strainer should be checked regularly.

# THE ROLAIRTROL® AIR SEPARATOR

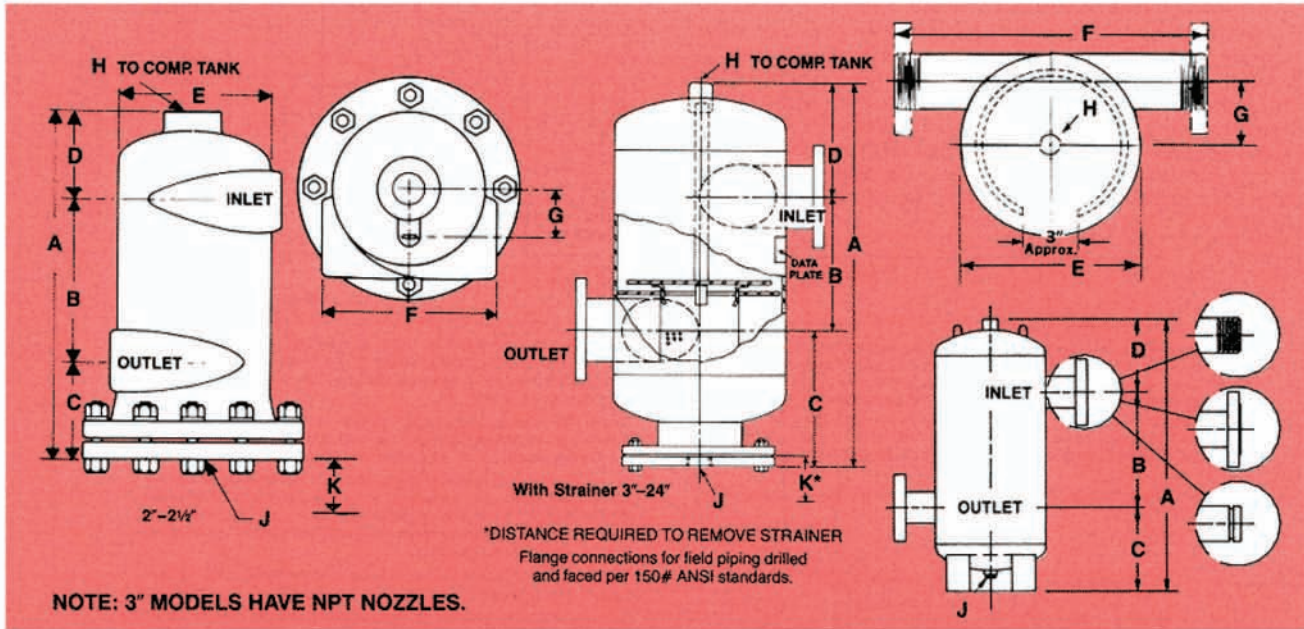

## Capacities, Dimensions and Weights

Model No.*	Capacity GPM	Size of Tangential Openings	DIMENSIONS IN INCHES											Strainer Free Area Sq. Inches	Approx. Shpg. Wt. Lbs.		
			A	B	C	D	E	F	Grooved F	G	H	J	K				
R-2	56	2	NPT	15½	7	4	4½	6½	7½	—	2	1	1	8½	32	55	
R-2½	90	2½		17½	7½	4½	5½	8½	9½	—	2½				45	90	
R-3(G)	190	3	NPT or Grooved	25½	8	9½	8½	10½	16½	16½	3½	1½	1½	12	66	95	
R-4(G)	300	4		30½	10	11½	9½	12½	20½	19½	4½				14	140	165
R-5(G)	500	5	Flanged or Grooved	36½	12	13½	10½	16	23½	23	5½	1½	2	2	17	220	
R-6(G)	700	6		42½	14	15½	13½	18	25½	25	5½				20	220	300
R-8(G)	1300	8		53½	18	19½	16½	24	31½	31	7½				23	310	460
R-10(G)	2000	10		64½	22	22½	20½	30	37½	37½	9½				29	435	860
R-12(G)	2750	12		77	27	27½	22½	36	46½	46½	11½				34	590	1200
R-14(G)	3400	14		89½	31½	32½	25½	42	54½	54½	14				37	715	1780
R-16(G)	4400	16		102½	36	36½	30½	48	62½	62½	16				42	919	2425
R-18(G)	5200	18		123	40½	44½	37½	54	70½	70½	18				52	1521	3410
R-20(G)	6300	20		135½	45	49½	41½	60	78	78	20				56	1989	5310
R-22(G)	7400	22		148½	49½	52½	45½	66	85½	85½	22				60	2322	6400
R-24(G)	8500	24	159½	54	56½	49½	72	93½	93½	24	64	2841	7530				
RL-2	56	2	NPT	15½	7	4	4½	6½	7½	—	2	1	1	8½	32	55	
RL-2½	90	2½		17½	7½	4½	5½	8½	9½	—	2½				45	90	
RL-3(G)	190	3	NPT or Grooved	25½	8	10½	8½	10½	16½	16½	3½	1½	1½	12	66	95	
RL-4(G)	300	4		30½	10	11½	9½	12½	20½	19½	4½				14	140	165
RL-5(G)	530	5	Flanged or Grooved	44½	14	16½	13½	18	25½	25	5½	1½	2	2	17	220	
RL-6(G)	850	6		54½	18	20	16½	24	31½	31	7½				20	220	300
RL-8(G)	1900	8		64½	22	22½	19½	30	37½	37½	9½				23	310	460
RL-10(G)	3600	10		75½	27	25½	22½	36	46½	46½	11½				29	435	860
RL-12(G)	4800	12		89	31½	35	28½	42	54½	54½	14				34	590	1200
RL-14(G)	6100	14		105½	36	38½	31½	48	62½	62½	16				37	715	1780
RL-16(G)	8000	16		123	40½	44½	37½	54	70½	70½	18				42	919	2425
RL-18(G)	9700	18		135½	45	48½	41½	60	78	78	20				52	1521	3410
RL-20(G)	12000	20		148	49½	52½	45½	66	85½	85½	22				56	1989	5310
RL-22(G)	15000	22		159½	54	56½	49½	72	93½	93½	24				60	2322	6400
RL-24(G)	17000	24	159½	54	56½	49½	72	93½	93½	24	64	2841	7530				

\*Model "RL" Rolairtrol Air Separators are manufactured less strainer. The G in the model number designates a Rolairtrol Air Separator with grooved tangential openings.  
 \*\*Do not use for construction. Dimensions are approximate and subject to change. Contact factory for certified dimensions. **Maximum Design Limitations 125 psig @ 350°F**

## COMPRESSION TANKS

The compression tank on a closed hydronic system serves a very important function in providing adequate pressurization under all operating conditions. Above all, a compression tank must be absolutely air tight. B&G Tanks are available nationally in ASME construction, are of black steel construction, thoroughly tested and guaranteed leakproof. Gauge glass tappings are included as standard. See B&G Air Control Design Manual for compression tank selection procedure. Always use B&G Airtrol Tank Fittings for minimum tank size and effective air control.

(For Sizes Not Shown, Use Multiple Tanks )

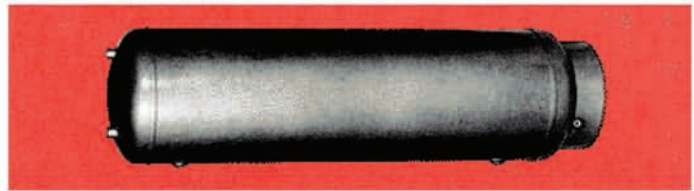

## DIMENSIONS AND WEIGHTS

MODEL NUMBER	DIMENSIONS - INCHES (MM)							TAPPINGS NPT INCHES (mm)	
	A	B	C	D	E	F	G	T	W
15	12 (305)	33 (838)	7 (178)	19 (483)	8 (203)	11-1/2 (292)	1-1/8 (29)	1	1/2
24	12 (305)	51 (1295)	7 (178)	37 (940)	8 (203)	11-1/2 (292)	1-1/8 (29)	1	1/2
30	14 (356)	48 (1219)	8-3/8 (213)	31-1/4 (794)	10 (254)	12 (305)	1-3/8 (35)	1	1/2
40	14 (356)	63 (1600)	8-3/8 (213)	46-1/4 (1175)	10 (254)	12 (305)	1-3/8 (35)	1	1/2
60	16 (406)	72 (1829)	9-1/4 (235)	53-1/2 (1359)	12 (305)	14 (356)	1 (25)	1	1/2
80	20 (508)	62 (1575)	10 (254)	42 (1067)	16 (406)	18 (457)	2-5/16 (59)	1	1/2
100	20 (508)	78 (1981)	10 (254)	58 (1473)	16 (406)	18 (457)	2-5/16 (59)	1	1/2
120	24 (610)	65 (1651)	11-1/8 (283)	42-3/4 (1086)	20 (508)	22 (559)	1-1/2 (38)	1	1/2
135	24 (610)	72 (1829)	11-1/8 (283)	49-3/4 (1264)	20 (508)	22 (559)	1-1/2 (38)	1	1/2
175	30 (762)	62-1/4 (1581)	13-1/2 (343)	35-1/4 (895)	22 (559)	26 (660)	1-3/8 (35)	1-1/2	1/2
220	30 (762)	77 (1956)	13-1/2 (343)	50 (1270)	22 (559)	26 (660)	1-3/8 (35)	1-1/2	1/2
240	30 (762)	84 (2134)	13-1/2 (343)	57 (1448)	22 (559)	26 (660)	1-3/8 (35)	1-1/2	1/2
305	30 (762)	105-3/4 (2686)	13-1/2 (343)	78-3/4 (2000)	22 (559)	26 (660)	1-3/8 (35)	1-1/2	1/2
400	36 (914)	93 (2362)	14-3/4 (375)	63-1/2 (1613)	28 (711)	30 (762)	1 (25)	1-1/2	1/2
505	36 (914)	116 (2946)	14-3/4 (375)	86-1/2 (2197)	28 (711)	30 (762)	1-1/8 (29)	1-1/2	1/2

Dimensions are subject to change. Not to be used for construction purposes unless certified.

## TYPICAL SPECIFICATIONS

### IAS

Furnish and install as shown on plans a horizontal in-line air separator designed to effectively separate free air in hydronic heating/cooling systems. The air separator shall be heavy duty cast iron designed to function satisfactorily at working pressures up to 175 PSI and liquid temperatures up to 300°F. The air separator shall have an integral weir designed to decelerate system flow to maximize air separation.

**NOTE: Choose either A or B to Complete this Specification.**

#### A. For Use with Conventional Compression Tanks

The in-line air separator shall further assist in controlling free air in the system by directing the separated air to a conventional compression tank while the bubble free water is circulated to the system. The in-line air separator shall allow expansion of the system fluid to be directed to the compression tank.

#### B. For Use with Precharged Bladder & Diaphragm Expansion Tanks

The in-line air separator shall further assist in eliminating free air from the system by directing the separated air to an air vent attached to the top of the air separator while the bubble free water is circulated to the system. The in-line air separator shall allow expansion of the system fluid to be directed to a precharged (CHOOSE ONE: BLADDER OR DIAPHRAGM) \_\_\_\_\_ expansion tank attached to the bottom.

Each air separator shall be ITT Bell & Gossett Model No. IAS-\_\_\_\_\_ In-Line Airtrol Fitting.

### COMPRESSION TANK

Furnish and install as shown on plans, a \_\_\_\_\_ gallon, \_\_\_\_\_ diameter x \_\_\_\_\_ long horizontal compression tank with two 1/2" NPT gauge glass tappings in one head and a minimum of two \_\_\_\_\_ NPT tappings (Select one: 15 thru 135 gallon tanks @ 1" or 175 thru 505 gallon tanks @ 1 1/2") in the shell. The tank must be designed, constructed and stamped for \_\_\_\_\_ psig @ 650°F in accordance with Section VIII, Division I of the ASME Boiler and Pressure Vessel Code, and registered with The National Board of Boiler and Pressure Vessel Inspectors. The compression tank shall be painted with one coat of air dry enamel.

A Manufacturer's Data Report for Pressure Vessels, Form U-1 as required by the provisions of the ASME Boiler and Pressure Vessel Code shall be furnished for each compression tank upon request.

Each compression tank shall be Bell & Gossett Model No. \_\_\_\_\_.

### ROLAIRTROL AIR SEPARATOR

Furnish and install, as shown on plans, a centrifugal type air separator. The unit shall have \_\_\_\_\_" (NPT/flanged/grooved) inlet and outlet connections tangential to the vessel shell. Vessel shell diameter to be three times the nominal inlet/outlet pipe diameter.

The unit shall have an internal stainless steel air collector tube with 1/2" diameter perforations and 63% open area designed to direct accumulated air to the compression tank via an NPT vent connection at top of unit.

The unit shall have a removable galvanized steel system strainer with 3/16" diameter perforations and a free area of not less than five times the cross-sectional area of the connecting pipe. A blowdown connection shall be provided to facilitate routine cleaning of the strainer. (Delete this paragraph if system strainer is not specified.)

Manufacturer to furnish data sheet specifying air collection efficiency and pressure drop at rated flow.

The air separator must be designed, constructed and stamped for 125 psig @ 350°F in accordance with Section VIII, Division I of the ASME Boiler and Pressure Vessel Code, and registered with the National Board of Boiler and Pressure Vessel Inspectors. The air separator(s) shall be painted with one shop coat of light gray air dry enamel.

A manufacturers' Data Report for Pressure Vessels, Form U-1 as required by the provisions of the ASME Boiler and Pressure Vessel Code shall be furnished for each air separator upon request.

Each air separator shall be Bell & Gossett Model No. R-\_\_\_\_\_ (with system strainer) or RL-\_\_\_\_\_ (less system strainer) Rolairtrol Air Separator for \_\_\_\_\_ GPM.

### AIRTROL TANK FITTING

Furnish and install a compression tank fitting as shown on plans. It must contain an air separating trap and liquid control baffle to assure unrestricted air flow to the tank and air-free liquid flow from the tank. It must include a manual vent for adjustment of air volume in the tank. Cast iron \_\_\_\_\_ psi (\_\_\_\_\_ kPa) working pressure. All units shall be Bell & Gossett Model No. \_\_\_\_\_ Airtrol Tank Fitting.

**xylem**  
Let's Solve Water

Xylem Inc.  
8200 N. Austin Avenue  
Morton Grove, Illinois 60053  
Phone: (847) 966-3700  
Fax: (847) 965-8379  
www.xylem.com/brands/bellgossett

Bell & Gossett is a trademark of Xylem Inc. or one of its subsidiaries.  
© 2012 Xylem Inc. A-300J September 2012