

AprilAire®

Ventilation

SUBMITTAL SHEET

Model 8100

Fresh Air Exchanger (ERV)

Project: _____

Dealer: _____

Architect: _____

Engineer: _____

Contractor: _____

Location: _____

Suppliers: _____

Date: _____

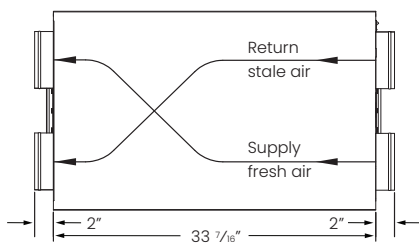
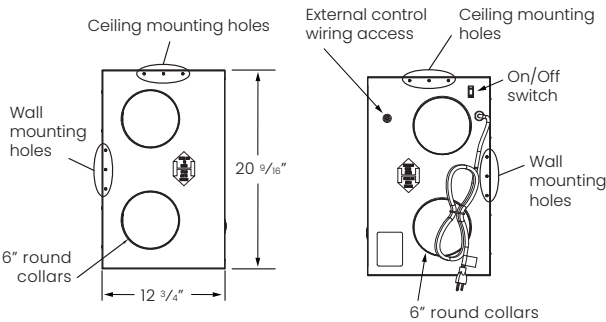

SPECIFICATIONS

Overall dimensions	33 7/16" W x 20 9/16" H x 12 3/4" D
EnergyMax® transfer core	12 1/8" x 12 1/8" x 10 3/4"
Air flow capacity	120 cfm @ 0.30 in. w.g. external ductwork resistance, i.e., 240 equivalent feet for each of the "fresh" and "stale" air streams
Performance	Apparent Sensible Effectiveness (ASE) – 77% at rated ventilation capacity with 72°F indoor temperature and 32°F outdoor temperature
Home size	Up to 7,500 sq. ft. home at rated air flow
Power requirements	120 VAC, 1.4A max. Unit equipped with a 3 ft. grounded power cord
Interior insulation	Entire interior surface is sealed with 1" single face insulation
Filters	(2) – 10 13/16" x 11 5/16" x 3/32" EZ Kleen® air filters
Unit weight and packaging	Total shipping weight with mounting hardware – 76 lbs.

FEATURES

- Provides a constant and controlled supply of fresh air year-round
- EnergyMax® transfer core technology uses the conditioned air being expelled to heat the incoming fresh air in the winter, reducing value loss from indoor air
- EnergyMax® core also removes moisture and cools the incoming fresh air in the summer the same way it warms the air in the winter
- Unit is designed, when properly installed, to achieve ASHRAE standard 62.2
- Can run continuously without a controller or on schedule when wired to an 8120X ventilation controller*
- Minimal maintenance required
- Quiet operation

*Pat. No. 9,874,366

BENEFITS

- Brings fresh air into the home
- Helps remove moisture from incoming air during warmer months
- Reduces indoor air pollution by expelling pollutants that can build up indoors
- Reduces energy costs by tempering incoming fresh air with outgoing air

When properly installed and set, the AprilAire Model 8100 will meet the mechanical ventilation requirements of:

- ASHRAE standard 62.2
- International Residential Code (IRC)
- International Mechanical Code (IMC)

ERV DUCTING INSTALLATION

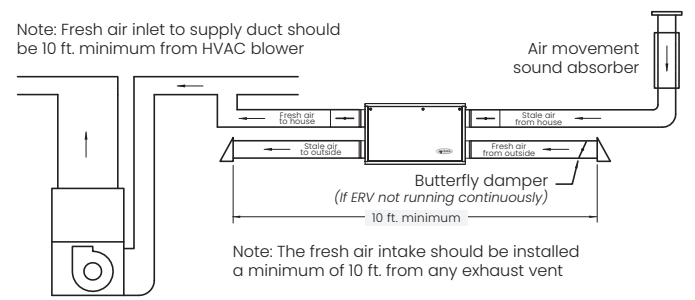

90-1747

WIRING TO 8120X VENTILATION CONTROLLER

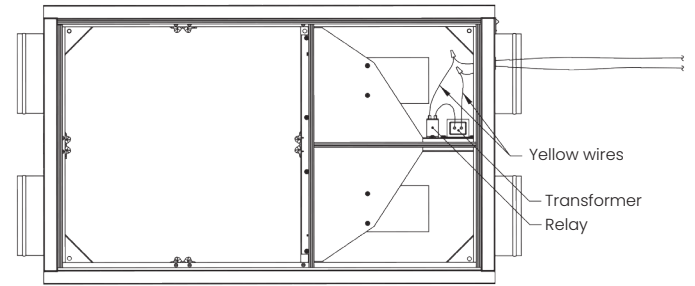

AprilAire Model 8120X Ventilation Controller

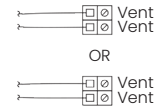

AprilAire Home Comfort Control™ or third-party control, 24VAC normally open

90-1749

SERVICE CLEARANCE FOR ERV

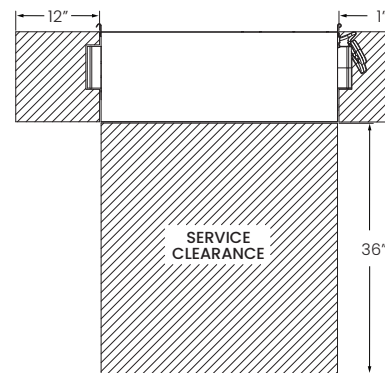

90-1743

The submittal is intended to show general, overall product dimensions and provide guidance for installation clearance. Drawings are not to scale. Ensure submittals are current. AprilAire reserves the right to make changes without notification or obligation.