

Bosch BVA 15 Series Air Handler

2-3-4-5 Ton Capacity

R410A



BOSCH

Installation Instructions



Table of Contents

1 Key to Symbols and Safety Instructions	4
1.1 Key to Symbols	4
1.2 Safety	4
2 General	6
2.1 Installations in High Humidity Environments	6
2.2 Unit Dimensions	9
3 Applications	10
3.1 Vertical Upflow	10
3.2 Vertical Downflow	10
3.3 Horizontal	10
3.4 Installation in an Unconditioned Space	12
4 Electrical wiring	13
4.1 Power Wiring	13
4.2 Control Wiring	13
4.3 Grounding	13
4.4 Electrical Data	13
4.5 Electric Heat Kit MCA/MOP Data	14
5 Airflow Performance	15
6 Ductwork	16
7 Refrigerant Connections	17
7.1 Condensate Drain Connection	17
8 Air Filter (Not Factory-Installed)	18
9 Filter Installation Dimensions	19
10 Maintenance	20
10.1 Cleaning Precautions	20
10.2 Regular Maintenance	20
11 Wiring Diagrams	21

1 Key to Symbols and Safety Instructions

1.1 Key to Symbols

Warnings



Warnings in this document are identified by a warning triangle printed against a grey background. Keywords at the start of a warning indicate the type and seriousness of the ensuing risk if measures to prevent the risk are not taken.

The following keywords are defined and can be used in this document:

- ▶ **DANGER** indicates a hazardous situation which, if not avoided, will result in death or serious injury.
- ▶ **WARNING** indicates a hazardous situation which, if not avoided, could result in death or serious injury.
- ▶ **CAUTION** indicates a hazardous situation which, if not avoided, could result in minor to moderate injury.
- ▶ **NOTICE** is used to address practices not related to personal injury.

Important information



This symbol indicates important information where there is no risk to people or property.

1.2 Safety

Please read before proceeding



WARNING:

- ▶ These instructions are intended as an aid to qualified, licensed service personnel for proper installation, adjustment and operation of this unit. Read these instructions thoroughly before attempting installation or operation. Failure to follow these instruction may lead to improper installation, adjustment, service or maintenance possibly resulting in fire, electrical shock, property damage, personal injury or death.



This document is customer property and is to remain with this unit. These instructions do not cover all the different variations of systems nor does it provide for every possible contingency to be met in connection with installation.



WARNING: FIRE, ELECTRICAL SHOCK, PROPERTY DAMAGE, PERSONAL INJURY, OR DEATH

- ▶ All phases of this installation must comply with NATIONAL, STATE AND LOCAL CODES. If additional information is required please contact your local distributor.



WARNING: ELECTRICAL SHOCK

- ▶ Disconnect all power to unit before installing or servicing. More than one disconnect switch may be required to deenergize the equipment. Hazardous voltage can cause severe personal injury or death.



WARNING: ELECTRICAL SHOCK

- ▶ If removal of the blower assembly is required, all disconnect switches supplying power to the equipment must be deenergized and locked (if not in sight of unit) so the field power wires can be safely removed from the blower assembly. Failure to do so can cause electrical shock resulting in personal injury or death.



WARNING: FIRE, ELECTRICAL SHOCK, PROPERTY DAMAGE, PERSONAL INJURY, OR DEATH

- ▶ Because of possible damage to equipment or personal injury, installation, service, and maintenance should be performed by trained, qualified service personnel. Consumer service is recommended only for filter cleaning / replacement. Never operate the unit with the access panels removed.

**WARNING:**

- ▶ This product can expose you to chemicals including Lead and Lead components, which are known to the State of California to cause cancer and birth defects or other reproductive harm. For more information go to www.P65Warnings.ca.gov.

**WARNING: ELECTRICAL SHOCK**

- ▶ The unit must be permanently grounded. Failure to do so can result in electrical shock causing personal injury or death.

**CAUTION: FIRE HAZARD**

- ▶ The material of plenum and ductwork must meet the latest edition of the NFPA 90B standard.

NOTICE:

- ▶ Make sure the blower motor support is tight (3-motor mounting bolts - Fig. 1). Then check if wheel is tightly secured to motor shaft before operating unit.

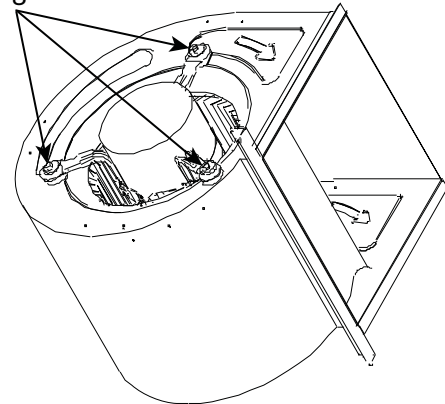
**Blower Motor
Mounting Bolt***Figure 1*

2 General

The unit can be positioned for bottom air return in the upflow position, left and right air return in the horizontal position and top air return in downflow position.

This air handler provides the flexibility for installation in any upflow, downflow or horizontal application. Adjust the motor speed by adjusting the motor wiring at the indoor control board. Select correct air flow according to airflow performance table in Section 5. Please refer to wiring diagram for motor speed selection instructions.

Please refer to Figure 8 for high and low voltage wiring connections.

To ensure the proper installation, select a solid and level site. Ensure enough clearance is maintained for installation and maintenance.

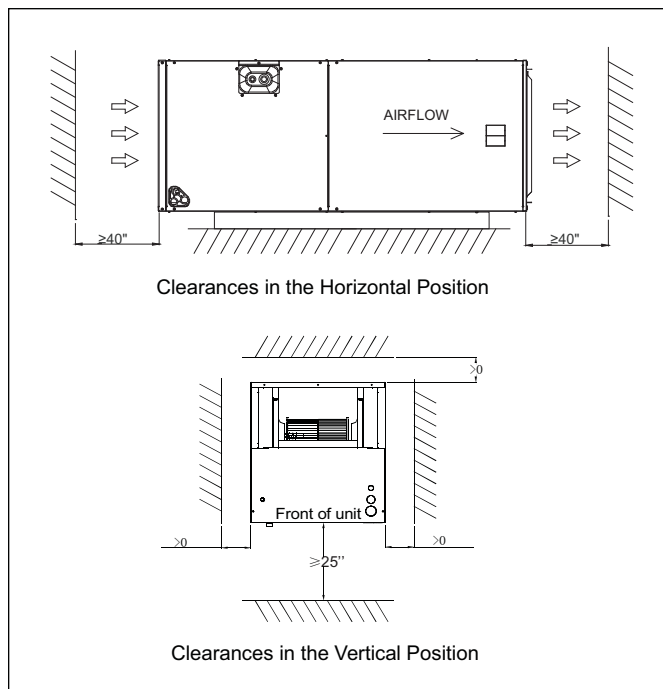

Figure 2 Required Clearances

NOTICE:

- ▶ The installed unit must have the required clearances as shown in Figure 2. Failure to follow these instructions may result in equipment damage and/or premature equipment failure.



WARNING: FIRE HAZARD

- ▶ Keep flammable material and vapors, such as gasoline, away from the air handler. Failure to follow these instructions can result in death, explosion, or fire.

2.1 Installations in High Humidity Environments

When the unit is installed in a hot and humid place, if the humidity inside the installation space exceeds 86°F and RH 80%, it is recommended to insulate the cabinet exterior. Use glass wool or polyethylene foam as insulation; the thickness should be more than 2 in. and it must fit inside the installation space opening.

Condensation may come from the surface of the insulation. Be sure to use insulation that is designed for use with HVAC Systems. Condensation may be produced on surface during cooling operation. It is also recommended to use auxiliary drain pan and secure the unit firmly to prevent it from falling. See Figures 3, 4, 5 & 6.



Refer to local code requirements for usage of auxiliary drain pans.

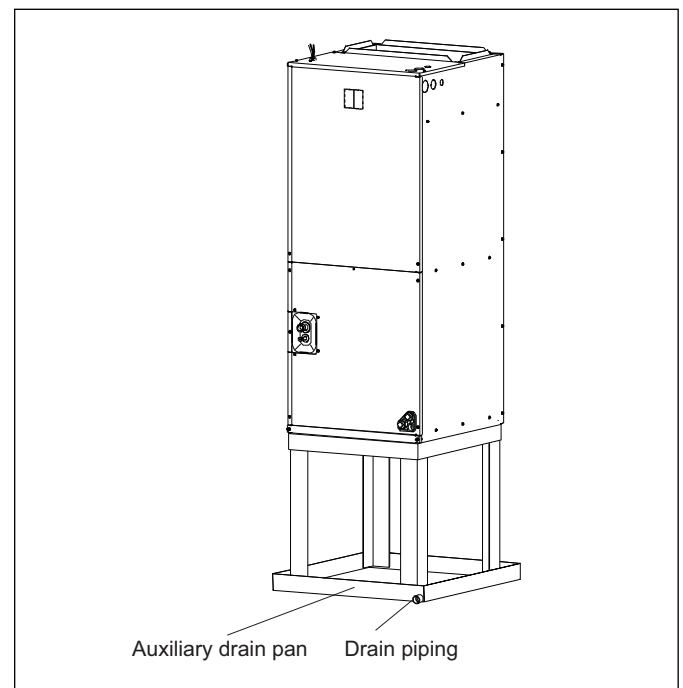

Figure 3 Installed Vertical Upflow

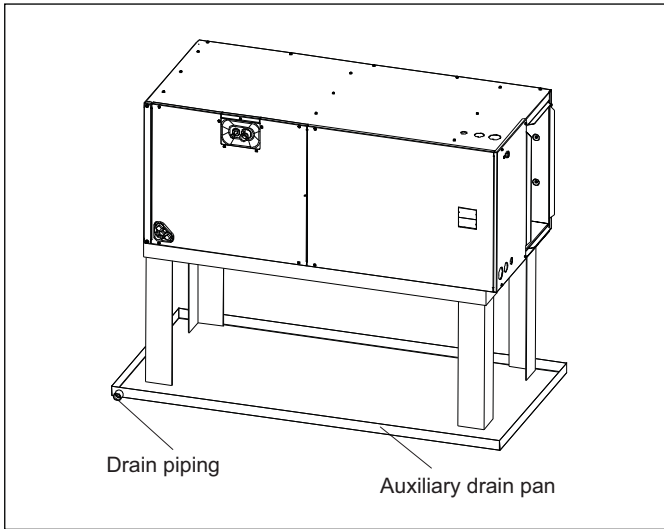

Figure 4 Installed Horizontal Right

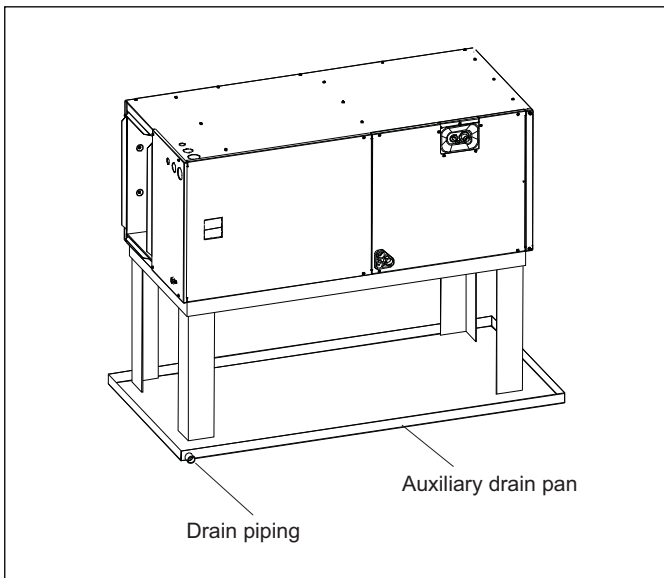

Figure 5 Installed Horizontal Left

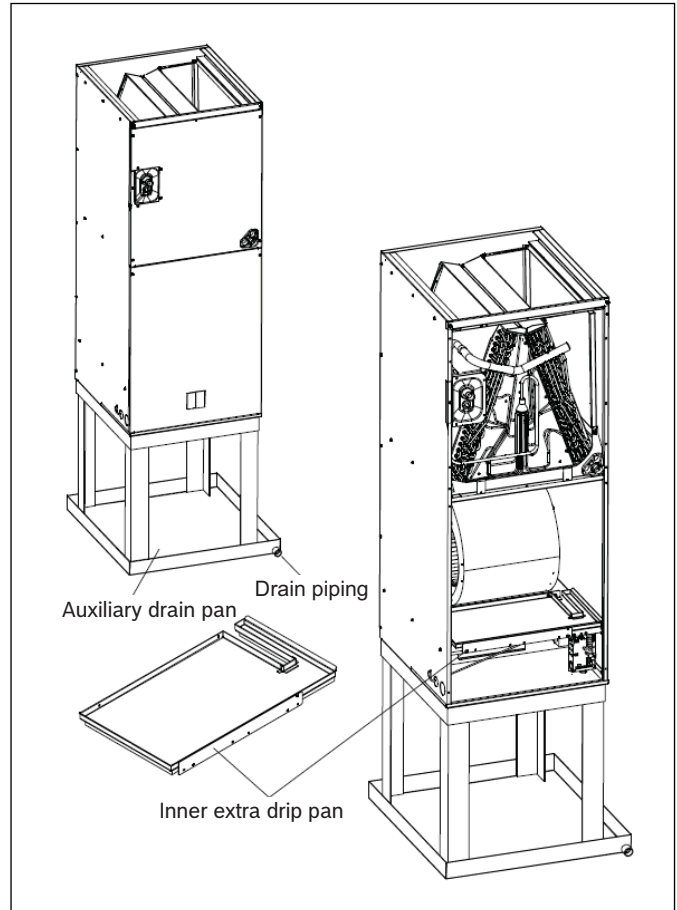

Figure 6 Installed Vertical Downflow

NOTICE:

- ▶ Inner extra drip pan is recommended to be installed for 4 and 5 ton vertical downflow applications installed in high humidity environments. This inner extra drip pan can be ordered from the manufacturer as a spare part number 8733953539. Refer to Figure 6.

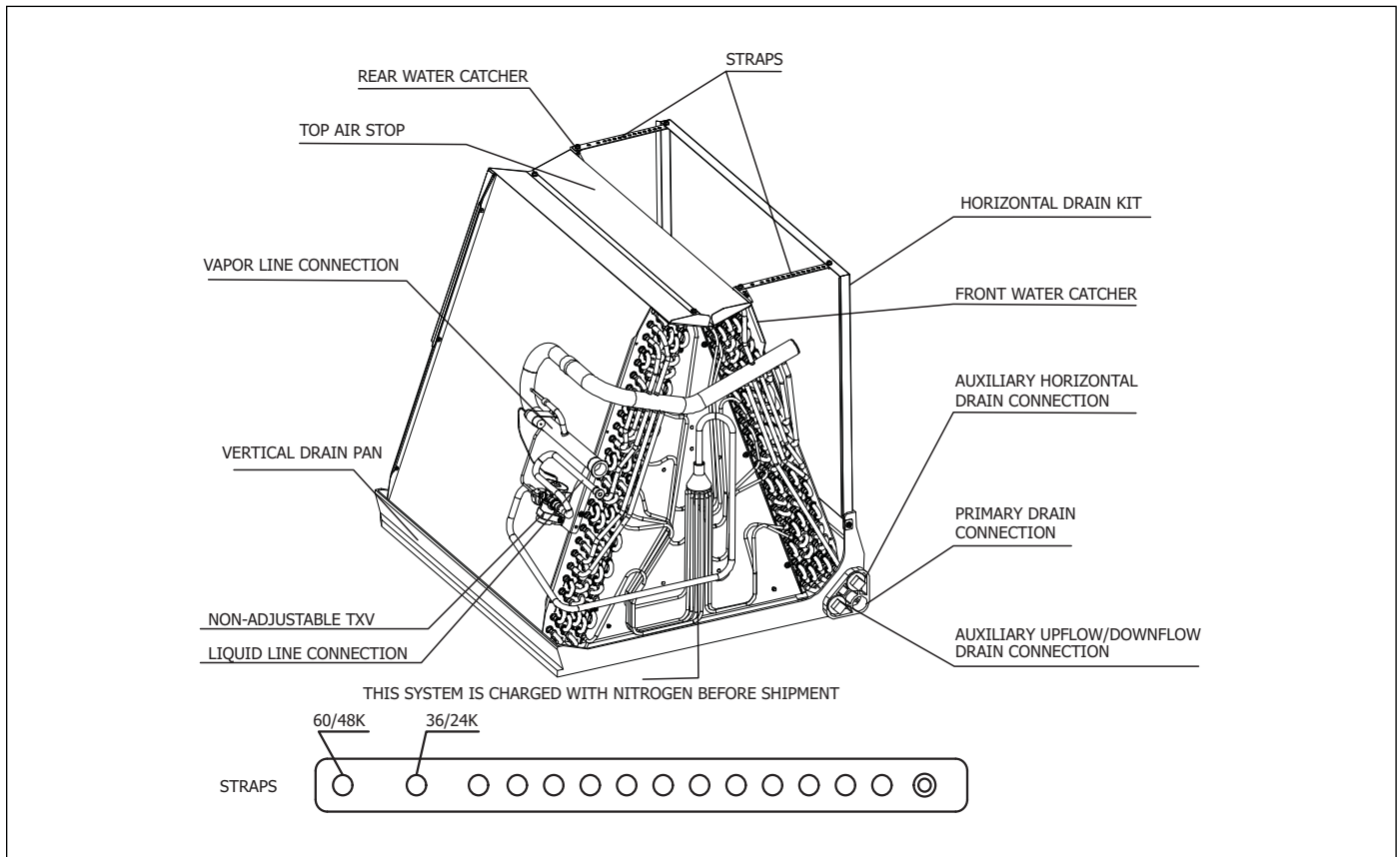

Figure 7 Indoor Coil and Drain Pan Set-Up

2.2 Unit Dimensions

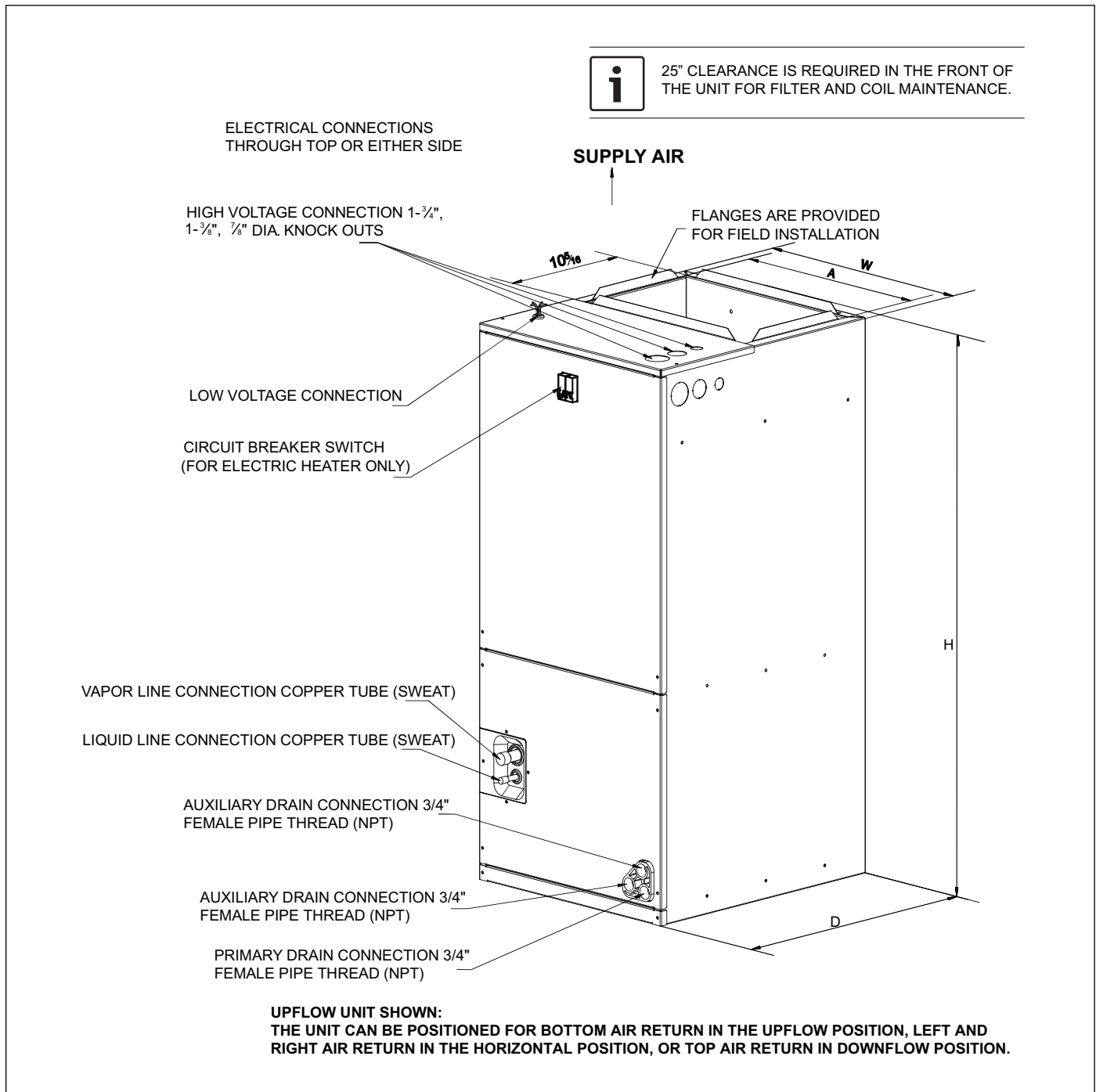

Figure 8

Model Size	Dimensions Inch [mm]				
	Unit Height "H"	Unit Width "W"	Unit Length "D"	Supply Duct "A"	Liquid Line / Vapor Line
24	46-1/2 [1180]	19-5/8 [500]	21-5/8 [550]	18 [456]	3/8 / 3/4 [9.5]/[19]
36	46-1/2 [1180]	19-5/8 [500]	21-5/8 [550]	18 [456]	3/8 / 3/4 [9.5]/[19]
48	54-1/2 [1385]	22 [560]	24 [610]	19-1/2 [496]	3/8 / 7/8 [9.5]/[22]
60	54-1/2 [1385]	22 [560]	24 [610]	19-1/2 [496]	3/8 / 7/8 [9.5]/[22]

Table 1

3 Applications

3.1 Vertical Upflow

- ▶ Vertical Upflow configuration is the factory default on all models (see Figure 8).
- ▶ If return air is to be ducted, install duct flush with floor. Use fireproof resilient gasket 1/8 to 1/4 in. thick between the ducts, unit and floor. Set unit on floor over opening.

i Torque applied to drain connections should not exceed 15 ft.lbs. For vertical upflow and horizontal right installations, dimensions for refrigerant and drain pipes may be found in Figure 9.

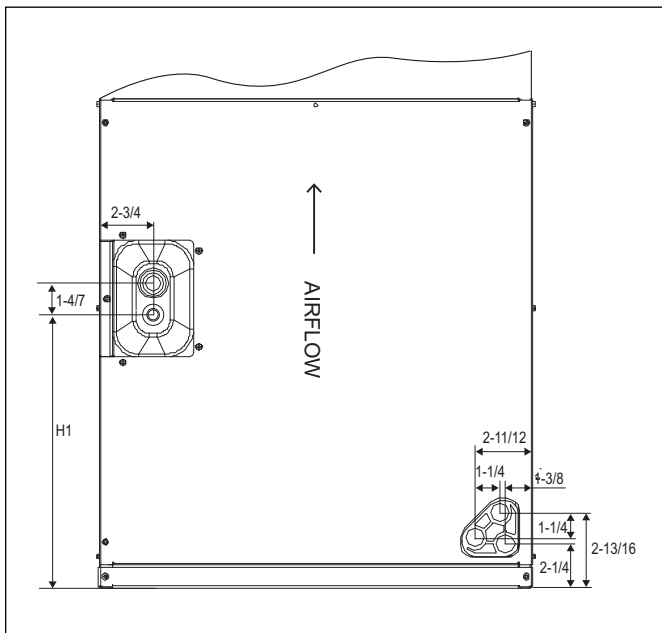

Figure 9 Dimensions For Air Handler (Coil Section)

Model Size	"H1" Inch [mm]
24/36	13-1/5 [335.5]
48/60	13-7/8 [352.8]

Table 2

3.2 Vertical Downflow

Conversion to Vertical Downflow:

A vertical upflow unit may be converted to vertical downflow. Remove the coil access panel and indoor coil and reinstall 180° from original position. See Figure 10 and Figure 11.

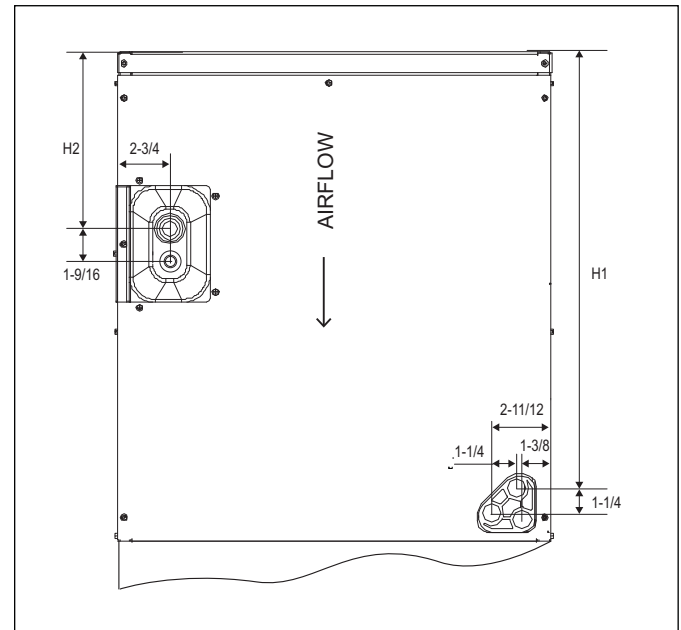

Figure 10 Dimensions For Air Handler (Coil Section)

Model Size	"H1" Inch [mm]	"H2" Inch [mm]
24/36	17-2/5 [441.5]	6-2/5 [162.5]
48/60	22-1/6 [563.5]	10-1/2 [267.2]

Table 3

3.3 Horizontal

Horizontal right is the default factory configuration for all models.

Conversion to Horizontal Left:

A vertical upflow unit may be converted to horizontal left by removing indoor coil assembly and reinstalling coil as shown for left hand air supply. See Figure 11.

- ▶ Rotate the unit 90° into the horizontal left position, with the coil compartment on the right and the blower compartment on the left.
- ▶ Reinstall the indoor coil 180° from original position. Ensure the retaining channel is fully engaged with the coil rail. See Figures 11 and 12.
- ▶ An additional field supplied drain pan kit is recommended when the unit is configured for the horizontal position over a finished ceiling and/or living space.

Steps for Changing Cabinet Orientation to Vertical Downflow OR Horizontal Left Orientation

1. Remove the screws and front panel (Figure 10, Step 1).
2. Pull out the coil (Figure 10, Step 2).
3. Replace the coil in the correct orientation and secure in place. (Figure 10, Step 3).

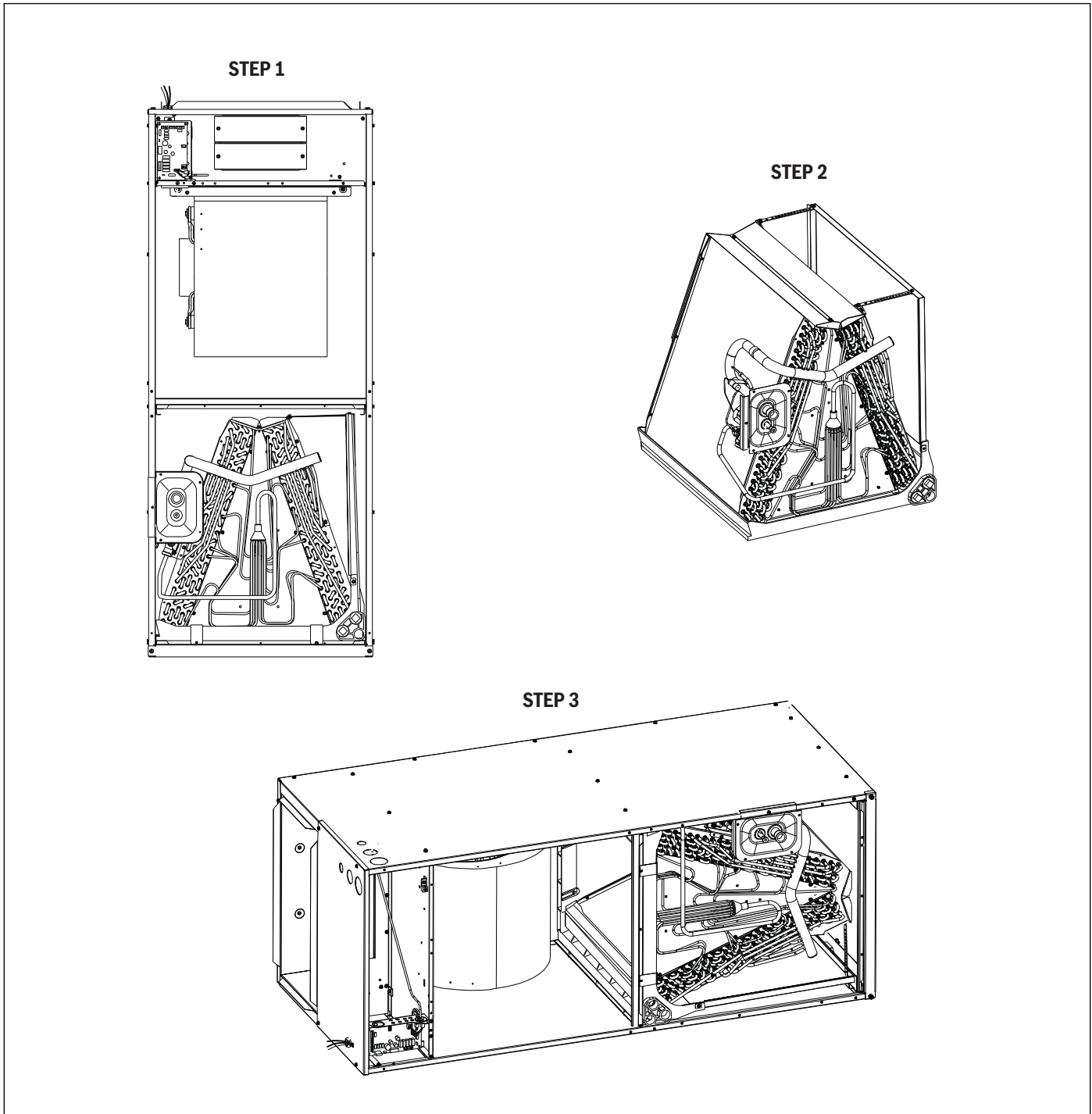

Figure 11 Vertical Downflow & Horizontal Left Applications Conversion

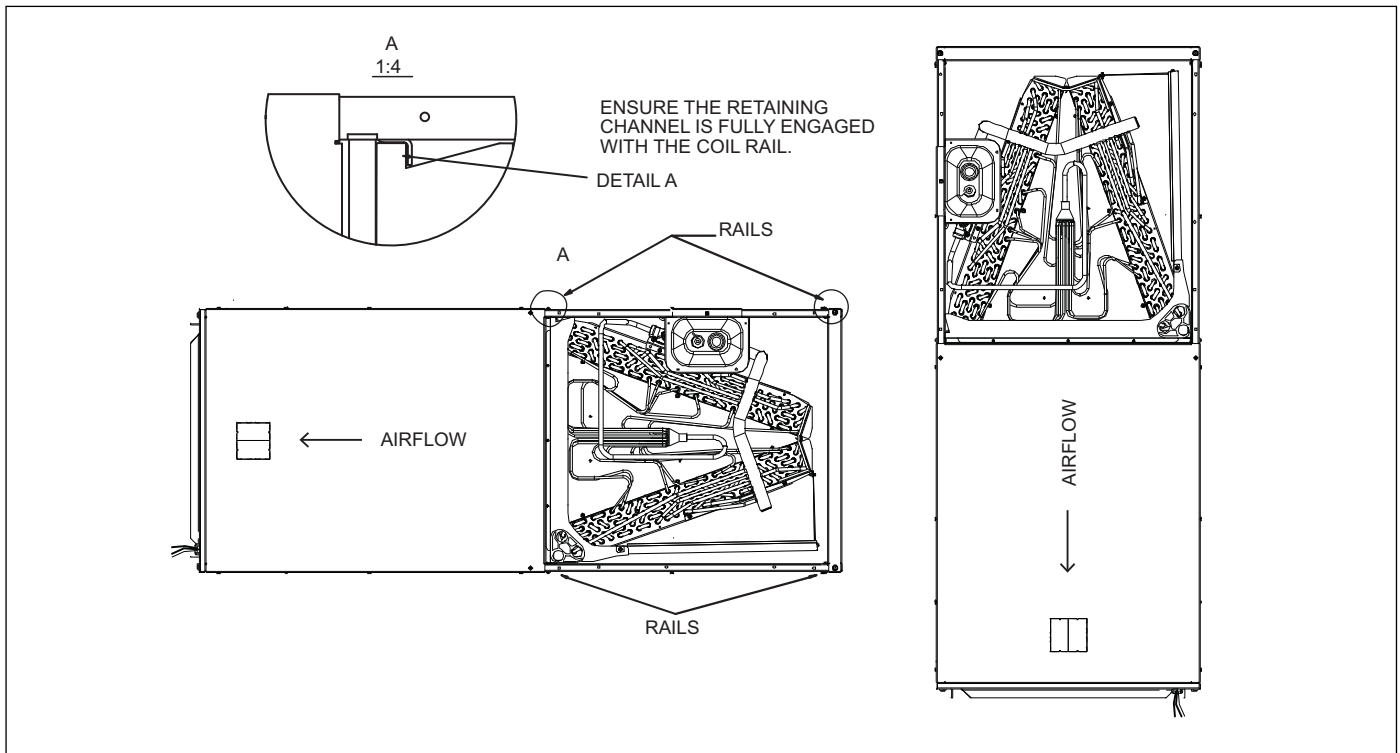

Figure 12 Vertical Downflow & Horizontal Left Applications

NOTICE:

- ▶ Horizontal units must be configured for right hand air supply or left hand air supply. Horizontal drain pan must be located under indoor coil. Failure to use the drain pan can result in property damage.

Conversion in Horizontal Direction:

Horizontal right-hand supply can be changed to horizontal left-hand supply by removing the indoor coil and reinstalling 180° from original.

3.4 Installation in an Unconditioned Space

NOTICE:

- ▶ There are two pairs of coil rails in the air handler for upflow and downflow application. If the air handler is installed in an unconditioned space, the two unused coil rails (Fig. 13) should be removed to minimize air handler surface sweating. The coil rails can be easily removed by unscrewing the 6 mounting screws from both sides of the cabinet.

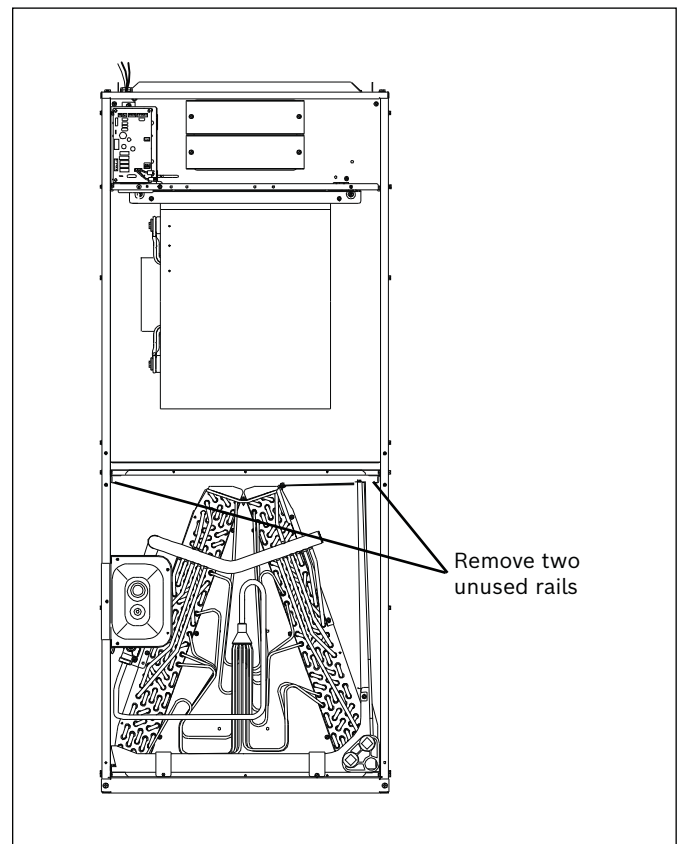

Figure 13

4 Electrical wiring

Field wiring must comply with the National Electric Code (C.E.C. in Canada) and any applicable local ordinances.



WARNING: ELECTRICAL SHOCK

- ▶ Disconnect all power to unit before installing or servicing. More than one disconnect switch may be required to deenergize the equipment. Hazardous voltage can cause severe personal injury or death.

4.1 Power Wiring

It is important that proper electrical power is available for connection to the unit being installed. See the unit nameplate, wiring diagram, and electrical data in the installation instructions for more detailed requirements.

- ▶ If required, install a branch circuit disconnect of adequate size, located within sight, and readily accessible from the unit.



When the Electric Heater is installed, units may be equipped with one or two 30-60 amp. circuit breakers. These breaker(s) protect the internal wiring in the event of a short circuit and serve as a disconnect. Circuit breakers installed within the unit do not provide over-current protection of the supply wiring and therefore may be sized larger than the branch circuit protection.

- ▶ Supply circuit power wiring must be 221°F minimum copper conductors only. See Electrical Data In this section for ampacity, wire size and circuit protector requirements. Supply circuit protection devices may be either fuses or "HACR" type circuit breakers.
- ▶ High voltage wiring may be run through knockout holes on the right, left or top of the unit.
- ▶ Three 7/8", 1-3/8", 1-3/4" dia. concentric knockouts are provided for running high voltage wiring to the unit. Refer to Figure-8 for High Voltage knock out locations.
- ▶ High voltage wiring must be connected to the red and black wiring in the control section of the air handler.

4.2 Control Wiring



Low voltage control wiring should not be run in conduit with high voltage wiring. Keep distance between the two conduits per local codes.

- ▶ 18 AWG. color-coded low voltage wire should be used for lengths less than 100ft. For wire lengths longer than 100 ft., 16 AWG. wire should be used.
- ▶ For low voltage wire connection location, see Figure 8.

- ▶ See wiring diagram located on inside of blower access panel of air handler for proper wiring instruction.
- ▶ After installation, ensure separation of low voltage and high voltage wiring is maintained.

4.3 Grounding



DANGER: ELECTRICAL SHOCK

- ▶ The unit must be permanently grounded. Failure to do so can result in electrical shock causing personal injury or death.

- ▶ The ground may consist of electrical wire or metal conduit when installed in accordance with existing electrical codes.
- ▶ Grounding may also be accomplished by attaching ground wire(s) to ground lug provided in the unit wiring compartment.
- ▶ Use of multiple supply circuits require grounding of each circuit to lug provided in unit.
- ▶ Ground lug is located on the upper right side of the cabinet.

4.4 Electrical Data

Model	Voltage	Hertz	HP	Speeds	Blower Motor FLA	Maximum Circuit Protector
24	208/230	60	1/5	3	2.0	15(A)
36	208/230	60	1/2	3	3.3	15(A)
48	208/230	60	1/2	3	4.2	15(A)
60	208/230	60	3/4	3	5.7	15(A)

Table 4

4.5 Electric Heat Kit MCA/MOP Data

Heat Kit Model	Air Handler Model	Electric Heat (kW)	MIN. Circuit Ampacity (MCA)		MAX. Fuse or Breaker (HACR) Ampacity		Fan speed		
			240 VAC	208 VAC	240 VAC	208 VAC	Low	Med	High
EHK-05B	24	5	27.5	24.1	30	25	●	●	●
EHK-08B		7.5	41.6	36.3	45	40	●	●	●
EHK-10B		10	52.5	45.8	55	50	●	●	●
EHK-05B	36	5	29.1	25.7	30	30	●	●	●
EHK-08B		7.5	43.2	37.9	45	40	●	●	●
EHK-10B		10	54.1	47.4	55	50	●	●	●
EHK-15B	48	15	54.1/25	47.4/21.6	55/25	50/25	●	●	●
EHK-05B		5	30.3	26.9	30	30	--	--	●
EHK-08B		7.5	44.4	39.1	45	40	--	--	●
EHK-10B		10	55.3	48.6	55	50	--	--	●
EHK-15B		15	55.3/25	48.6/21.6	55/25	50/25	--	--	●
EHK-20B	60	20	55.3/50	48.6/43.3	55/50	50/45	--	--	●
EHK-05B		5	32.1	28.7	35	30	●	●	●
EHK-08B		7.5	46.2	40.9	50	45	●	●	●
EHK-10B		10	57.1	50.4	60	50	●	●	●
EHK-15B		15	57.1/25	50.4/21.6	60/25	50/25	●	●	●
EHK-20B		20	57.1/50	50.4/43.3	60/50	50/45	●	●	●

Table 5 Suitable heat kits for AHU multi position installation

- Electric Heat kits are suitable for AHU 4-way position installation
- Heat pump systems require a specified airflow. Each ton of cooling requires between 350 and 450 cubic feet of air per minute (CFM), or 400 CFM nominally
- All electric heat kits include breaker(s) for each heater element for short circuit protection
- EHK-05B, EHK-08B, and EHK-10B are single circuit (contain 1 heater element)
- EHK-15B and EHK-20B are dual circuit (contain 2 heater elements)
- Blower motor load is included in MCA and MAX Fuse/Breaker size (included in first circuit for EHK-15B and EHK-20B)
- MCA and MAX Fuse/Breaker size for the second circuit for EHK-15B and EHK-20B includes only the second circuit element load

Heater Kit Accessories

Model	Description	24	36	48	60
EHK05B	5 kW Heat Kit, Double Pole Breaker	●	●	●	●
EHK08B	7.5 kW Heat Kit, Double Pole Breaker	●	●	●	●
EHK10B	10 kW Heat Kit, Double Pole Breaker	●	●	●	●
EHK15B	15 kW Heat Kit, Double Pole Breaker	X	●	●	●
EHK20B	20 kW Heat Kit, Double Pole Breaker	X	X	●	●

Table 6

[● means available, X means not available]

5 Airflow Performance

Airflow performance data is based on cooling performance with a coil and no filter in place. Check the performance table for appropriate unit size selection. External static pressure should stay within the minimum and maximum limits shown in the table below in order to ensure proper operation of both cooling, heating, and electric heating operation.

Air Handler Model Size	Motor Speed		SCFM								
			External Static Pressure-Inches W.C. [kPa]								
			0[0]	0.1[.02]	0.2[.05]	0.3[.07]	0.4[.10]	0.5[.12]	0.6[.15]	0.7[.17]	0.8[.20]
24	Low	SCFM	743	692	619	550	494	409	339	245	190
		Watts	207	204	200	195	190	184	178	168	161
		Amps	0.91	0.89	0.87	0.85	0.84	0.81	0.79	0.76	0.73
	Medium (Default)	SCFM	958	913	865	810	711	656	576	467	368
		Watts	241	239	236	231	223	218	211	201	191
		Amps	1.05	1.04	1.03	1.00	0.97	0.95	0.92	0.89	0.84
	High	SCFM	1107	1066	1022	973	897	807	697	662	526
		Watts	315	310	305	299	293	280	270	262	246
		Amps	1.37	1.34	1.33	1.30	1.27	1.20	1.19	1.15	1.09
36	Low	SCFM	1028	985	930	859	781	712	649	571	468
		Watts	362	353	345	335	323	313	303	290	276
		Amps	1.64	1.62	1.60	1.57	1.54	1.51	1.49	1.45	1.42
	Medium (Default)	SCFM	1315	1266	1208	1146	1065	981	866	775	686
		Watts	406	399	392	385	372	361	344	331	320
		Amps	1.82	1.80	1.78	1.75	1.72	1.69	1.65	1.62	1.59
	High	SCFM	1532	1478	1421	1347	1284	1184	1082	932	805
		Watts	524	513	502	491	478	462	446	423	407
		Amps	2.39	2.36	2.34	2.31	2.28	2.23	2.2	2.14	2.11
48	Low	SCFM	1336	1310	1282	1234	1182	1140	1049	925	833
		Watts	492	483	474	463	452	443	422	393	374
		Amps	2.24	2.22	2.17	2.13	2.10	1.93	2.03	1.90	1.87
	Medium (Default)	SCFM	1654	1610	1569	1510	1461	1394	1350	1265	1034
		Watts	550	537	526	512	503	489	475	458	416
		Amps	2.40	2.38	2.35	2.32	2.30	2.18	2.16	2.08	2.04
	High	SCFM	1918	1875	1817	1771	1715	1651	1584	1511	1395
		Watts	717	703	686	670	652	635	617	600	570
		Amps	3.20	3.18	3.14	3.10	3.04	3.00	2.90	2.87	2.85
60	Low	SCFM	1726	1693	1655	1637	1584	1500	1421	1328	1217
		Watts	678	658	639	619	602	576	553	526	495
		Amps	2.95	2.87	2.78	2.69	2.62	2.52	2.42	2.31	2.18
	Medium (Default)	SCFM	1983	1933	1879	1828	1760	1685	1597	1507	1403
		Watts	695	675	655	635	615	596	574	550	522
		Amps	3.02	2.93	2.85	2.76	2.67	2.59	2.5	2.4	2.28
	High	SCFM	2138	2086	2024	1952	1873	1797	1722	1646	1516
		Watts	793	773	751	726	702	679	658	638	604
		Amps	3.45	3.37	3.27	3.17	3.06	2.97	2.88	2.79	2.65

Table 7

Bold outlined areas represent airflow outside of the required 300-450 cfm/ton range.

NOTES:

1. The high stage airflow must be used as the rated airflow for the full load operation of machine.
2. The rated airflow of systems without electric heater kits requires between 300 and 450 cubic feet of air per minute (CFM).
3. The rated airflow of systems with electric heater kits requires between 350 and 450 cubic feet of air per minute (CFM).
4. The air distribution system has the greatest effect on airflow. Therefore, the contractor should use only industry-recognized procedures.
5. Duct design and construction should be carefully done. System performance can be lowered dramatically through poor design or workmanship.
6. Air supplier ducts should be located along the perimeter of the conditioned space and properly sized. Improper location or insufficient air flow may cause drafts or noise in the ductwork.
7. Installers should balance the air distribution system to ensure proper quiet airflow to all rooms in the home. An air velocity meter or airflow hood can be used to balance and verify branch and system airflow (CFM).

6 Ductwork

Field ductwork must comply with the National Fire Protection Association NFPA 90A, NFPA 90B and any applicable local ordinance(s).



WARNING: FIRE HAZARD AND CARBON MONOXIDE

- ▶ Do not, under any circumstances, connect return ductwork to any other heat producing device such as fireplace insert, stove, etc. Unauthorized use of such devices may result in fire, carbon monoxide poisoning, explosion, personal injury or property damage.

Sheet metal ductwork run in unconditioned spaces must be insulated and covered with a vapor barrier. Fibrous ductwork may be used if constructed and installed in accordance with SMACNA Construction Standard on Fibrous Glass Ducts. Ductwork must comply with National Fire Protection Association as tested by U/L Standard 181 for Class I Air Ducts. Check local codes for requirements on ductwork and insulation.

- ▶ Duct system must be designed within the range of external static pressure the unit is designed to operate against. It is important that the system airflow be adequate. Make sure supply and return ductwork, grills, special filters, accessories, etc. are accounted for in total resistance. See airflow performance tables in Section 5 of this manual.
- ▶ Design the duct system in accordance with "ACCA" Manual "D" Design for Residential Winter and Summer Air Conditioning and Equipment Selection. Latest editions are available from: "ACCA" Air Conditioning Contractors of America, 1513 16th Street, N.W., Washington, D.C. 20036. If duct system incorporates flexible air duct, be sure pressure drop information (straight length plus all turns) shown in "ACCA" Manual "D" is accounted for in system.
- ▶ Supply plenum should be attached to the 3/4" duct flanges supplied with the unit. Attach flanges around the blower outlet.



If an elbow is included in the plenum close to the unit, it must not be smaller than the dimensions of the supply duct flange on the unit.



The front flange on the return duct (if connected to the blower casing) must not be screwed into the area where the power wiring is located. Drills or sharp screw points can damage insulation on wires located inside unit.

- ▶ Secure the supply and return ductwork to the unit flanges, using proper fasteners for the type of duct used and tape the duct-to-unit joint as required to prevent air leaks.

7 Refrigerant Connections

Keep the coil connections sealed until refrigerant connections are made. Refer to the Bosch IDS Condenser Section Installation, Operation, and Maintenance Manual for details on line sizing, tubing installation, and charging information.

Coil is factory charged with Nitrogen. Evacuate the system before charging with refrigerant.

Install refrigerant lines so that they do not block service access to the front of the unit.

Nitrogen should flow through the refrigerant lines while brazing.

Use a brazing shield to protect the cabinet's paint and a wet rag to protect the rubber grommet and input pipe's piston seal ring from being damaged by torch flames. Use a wet rag or an approved heat paste to protect the TXV sensing bulb during the brazing process. Refer to Figure 13.

After the refrigerant line connections are made, seal the gap around the connections with pressure sensitive gasket.

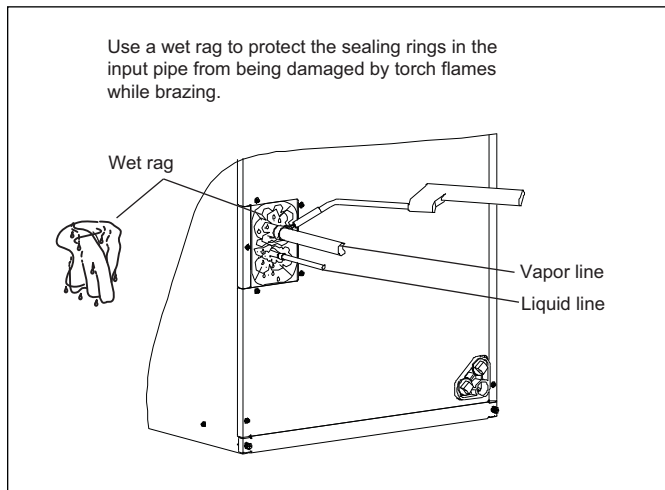

Figure 14

After the brazing work is finished, make sure to check that there is no refrigerant leakage. After checking for vapor leaks, be sure to insulate the pipe connections, refer to Figure 14.

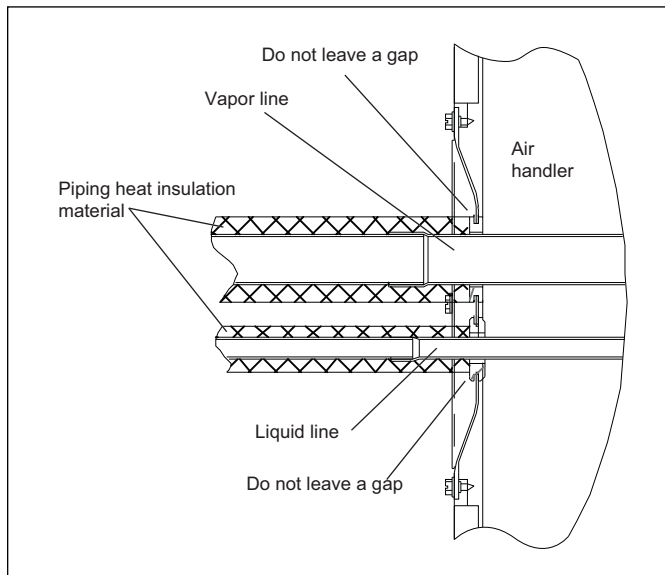

Figure 15

7.1 Condensate Drain Connection

Consult local codes for specific requirements.

Refer to Figure 15 and the information below for required condensate drain trap installation.

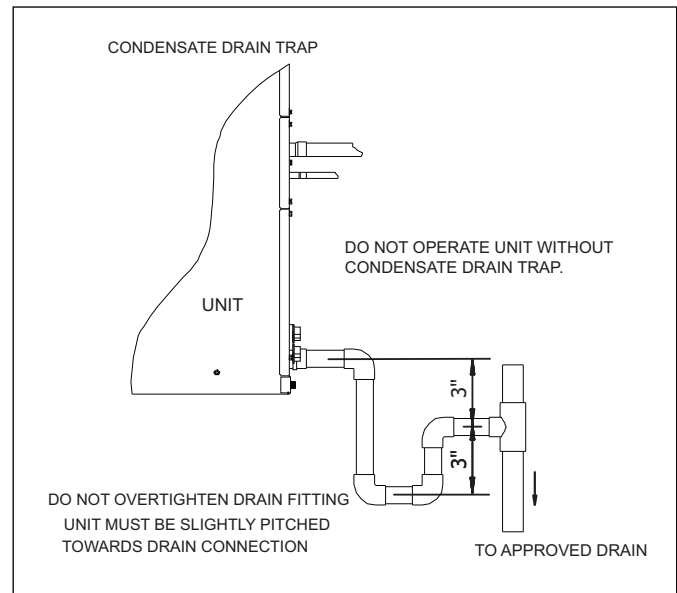

Figure 16



1. When making drain fitting connections to the drain pan, use a thin layer of Teflon paste, silicone or Teflon tape and install by hand tightening.
2. When making drain fitting connections to drain pan, do not overtighten. Over tightening fittings can split pipe connections on the drain pan.

- ▶ Ensure drain lines do not block access to front of the unit. Minimum clearance of 24 inches is required for filter, coil or blower removal and service access.
- ▶ Make sure unit is pitched slightly toward primary drain connection so that water will drain completely from the pan.
- ▶ Do not reduce drain line size to less than connection size provided on condensate drain pan.
- ▶ All horizontal drain lines must be pitched downward away from the unit at a minimum of 1/8" per foot of line to ensure proper drainage.
- ▶ Do not connect condensate drain line to a closed or open sewer pipe. Run condensate to an open drain or run line to a safe outdoor area.
- ▶ The drain line should be insulated where necessary to prevent sweating and damage due to condensate forming on the outside surface of the line.
- ▶ Make provisions for disconnecting and cleaning of the primary drain line should it become necessary. Install a 3 inch trap in the primary drain line as close to the unit as possible. Make sure that the top of the trap is below connection to the drain pan to allow complete drainage of pan (See Figure 15).

- ▶ Auxiliary drain line should be run to a place where condensate will be noticeable. Homeowner should be warned that a problem exists if water should begin running from the auxiliary drain line.
- ▶ Plug the unused drain connection with the plugs provided in the parts bag provided with the unit. Use a thin layer of teflon paste, silicone or teflon tape to form a water tight seal.
- ▶ Test condensate drain pan and drain line after installation is complete. Pour water into drain pan, enough to fill drain trap and line. Check to ensure drain pan is draining completely, no leaks are found in drain line fittings, and water is draining from the termination of the primary drain line.

8 Air Filter (Not Factory-Installed)

Filters are not included with the unit and must be field supplied.

An external filter or other means of filtration must be properly sized for a maximum of 300 feet/min. air velocity or what is recommended for the type of filter installed.

Filter application and placement are critical to airflow, which may affect the heating and cooling system performance. Reduced airflow can shorten the life of the system's major components, such as motor, elements, heat relays, evaporator coil or compressor. Consequently, we recommend that the return air duct system have only one filter location. For systems without a return air filter grill, multiple filter grills can be installed at each of the return air openings.

If adding high efficiency filters or electronic air filtration systems, it is very important that the air flow is not reduced. If air flow is reduced the overall performance and efficiency of the unit will be reduced. It is strongly recommended that a professional installation technician is contacted to ensure such filtration systems are installed correctly.



Do not double filter the return air duct system. Do not filter the supply air duct system. This will change the performance of the unit and reduce airflow.



WARNING: FIRE HAZARD

- ▶ Do not operate the system without filters. A portion of the dust suspended in the air may temporarily lodge in the duct runs and at the supply registers. Any circulated dust particles could be heated and charred by contact with the air handler elements. This residue could soil ceilings, walls, drapes, carpets and other articles in the house. Soot damage may occur with filters in place, when certain types of candles, oil lamps or standing pilots are burned.

9 Filter Installation Dimensions

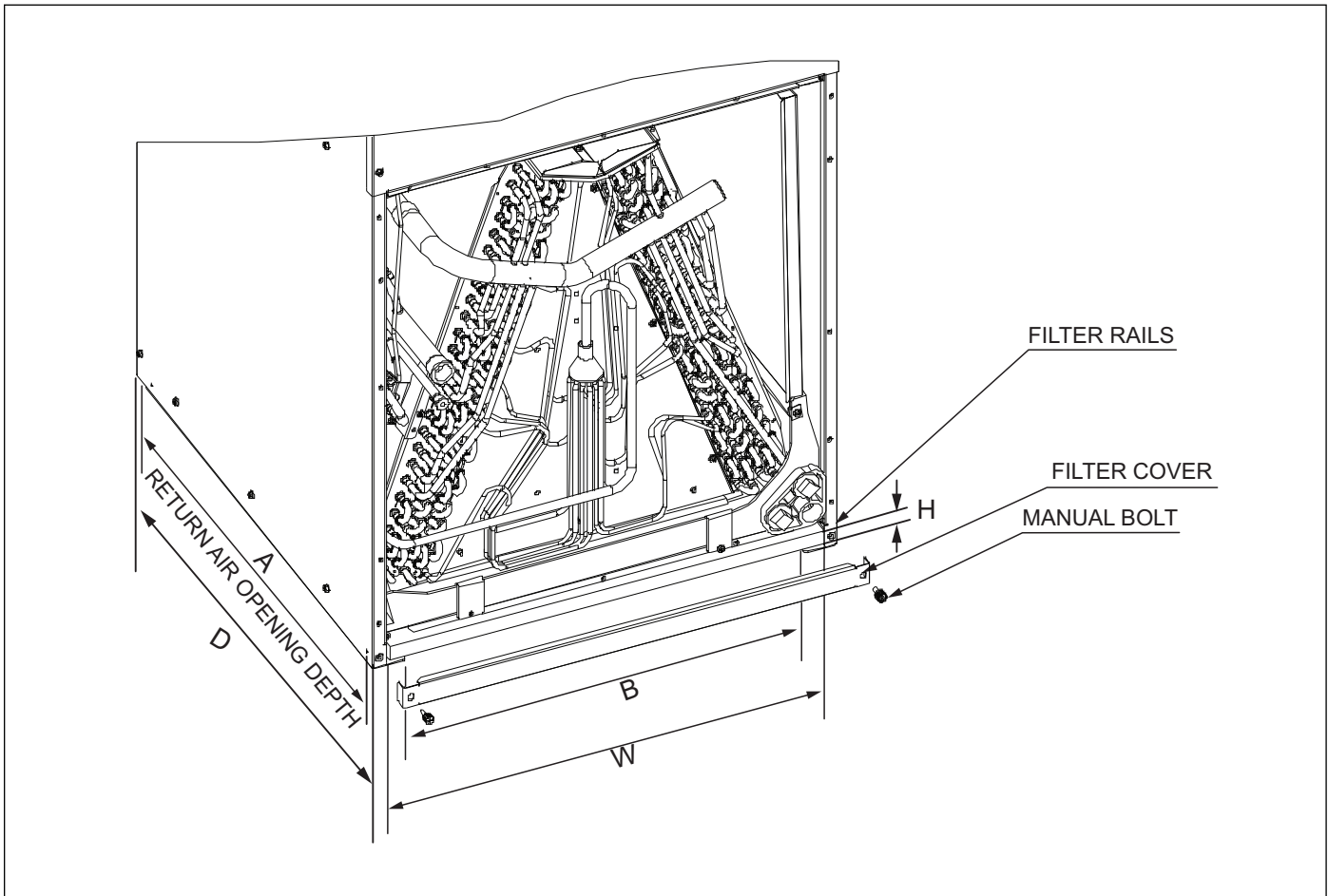

Figure 17 Filter Installation



Filters are not included with the unit and must be field supplied.

Dimensional data

Model	Filter Size In. [mm]	"W" In. [mm]	"D" In. [mm]	"H" In. [mm]	Return width "A" In. [mm]	Return length "B" In. [mm]
24/36	18x20 [457x508]	18.3 [466]	21.6 [548]	1 [25.4]	20.8 [528]	16.3 [414]
48/60	20x22 [508x559]	20.7 [526]	23.9 [608]	1 [25.4]	23 [584]	18.8 [478]

Table 8

Air filter removal / installation

- ▶ Remove bolts manually, remove air filter cover, see Figure 16.
- ▶ Hold the edge of the air filter and pull out.
- ▶ Install new filter so that the arrow on the filter is in the same direction as airflow.
- ▶ If reusable filter is being used, please clean according to the manufacturer's specification prior to re-installation.

10 Maintenance



For continuing high performance and to minimize possible equipment failure, annual maintenance must be performed on this equipment.

10.1 Cleaning Precautions



WARNING:

- ▶ Any unit repairs must be performed by qualified service personnel only.



WARNING: BEFORE CLEANING AND MAINTENANCE

- ▶ Always turn off your heat pump and disconnect its power supply before cleaning or maintenance.



CAUTION:

- ▶ When removing filter, do not touch metal parts in the unit. The sharp metal edges can cut you.



WARNING: FIRE HAZARD

- ▶ Do not use chemicals or chemically treated cloths to clean the unit .
- ▶ Do not use benzene, paint thinner, polishing powder or other solvents to clean the unit.
- ▶ Do not operate the system without a filter in place

10.2 Regular Maintenance

Your heat pump must be inspected annually by a qualified service technician. Your annual system inspection must include:

1. Inspect the air filter every ninety days or as often as needed. If blocked or obstructed, clean or replace at once.
2. Inspection and/or cleaning of the blower wheel housing and motor.
3. Inspection and cleaning of indoor and outdoor coils as required.
4. Inspection and/or cleaning of the indoor coil drain pan and drain lines, as well as auxiliary drain pan and lines.
5. Check all electrical wiring and connections. Correct as needed, referring to the wiring diagram.

11 Wiring Diagrams



WARNING: ELECTRICAL SHOCK

- ▶ Disconnect all power before servicing or installing this unit. Multiple power sources may be present. Failure to do so may cause property damage, personal injury or death.



DANGER: ELECTRICAL SHOCK

- ▶ This unit must be properly grounded and protected by a circuit breaker or fuse.



WARNING: ELECTRICAL SHOCK

- ▶ These units must be wired and installed in accordance with all National and Local Safety Codes.

- ▶ To avoid electrical shock, please ensure:
 - The heat pump is properly grounded
 - The main power plug to the heat pump has been joined with the ground wiring (DO NOT ALTER THIS).
- ▶ Do not strain the power wiring.



Dashed lines in the following thermostat wiring diagrams refer to optional wiring (wiring for Electric Heat). For thermostat wiring please refer to the Owner's Manual of the thermostat.

Electric wiring gauge for H/P systems

Model(Btu/h)		24	36	48	60	
Power	Phase	Single				
	Voltage/frequency	208/230VAC, 60Hz				
Line Gauge	Input Current Fuse	Indoor unit (A)	15A	15A	15A	15A
	Indoor Unit Power Line	Line Quantity	3	3	3	3
		Line Diameter (AWG)	14	14	14	14
	Outdoor Unit Power Line	Line Quantity	3	3	3	3
		Line Diameter (AWG)	14	12	10	10
	Outdoor -Indoor Signal Line	Line Quantity	4	4	4	4
Line Diameter (AWG)		18	18	18	18	
Thermostat Signal Line	Line Quantity	5	5	5	5	
	Line Diameter (AWG)	18	18	18	18	

Table 9

Wiring for 3H and 1C thermostat

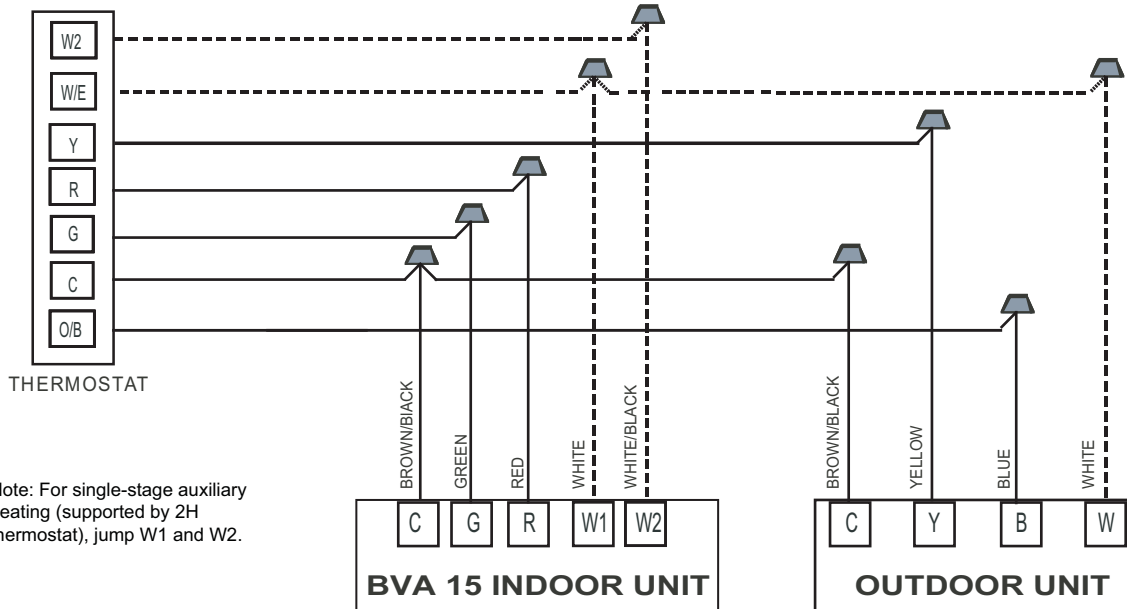

Note: For single-stage auxiliary heating (supported by 2H thermostat), jump W1 and W2.

Figure 18 Thermostat wiring diagram for BOVB 18 with BVA 15

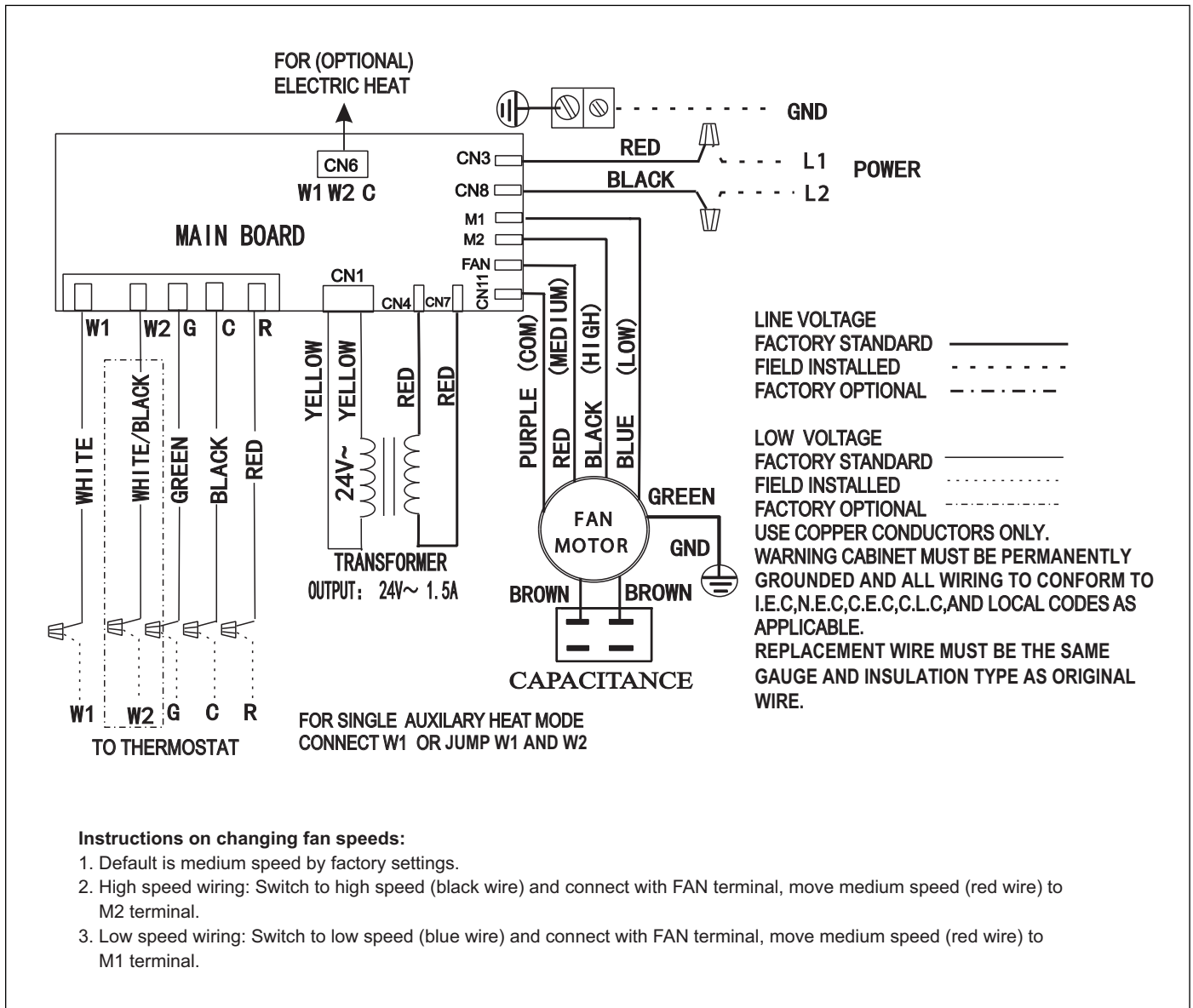

Figure 19 Indoor Unit Wiring Diagram

Fan speed	Terminal		
	Fan	M1	M2
Medium	Red	Blue	Black
High	Black	Blue	Red
Low	Blue	Red	Black

Table 10 Fan Speed Terminal Wiring

Unit Wiring

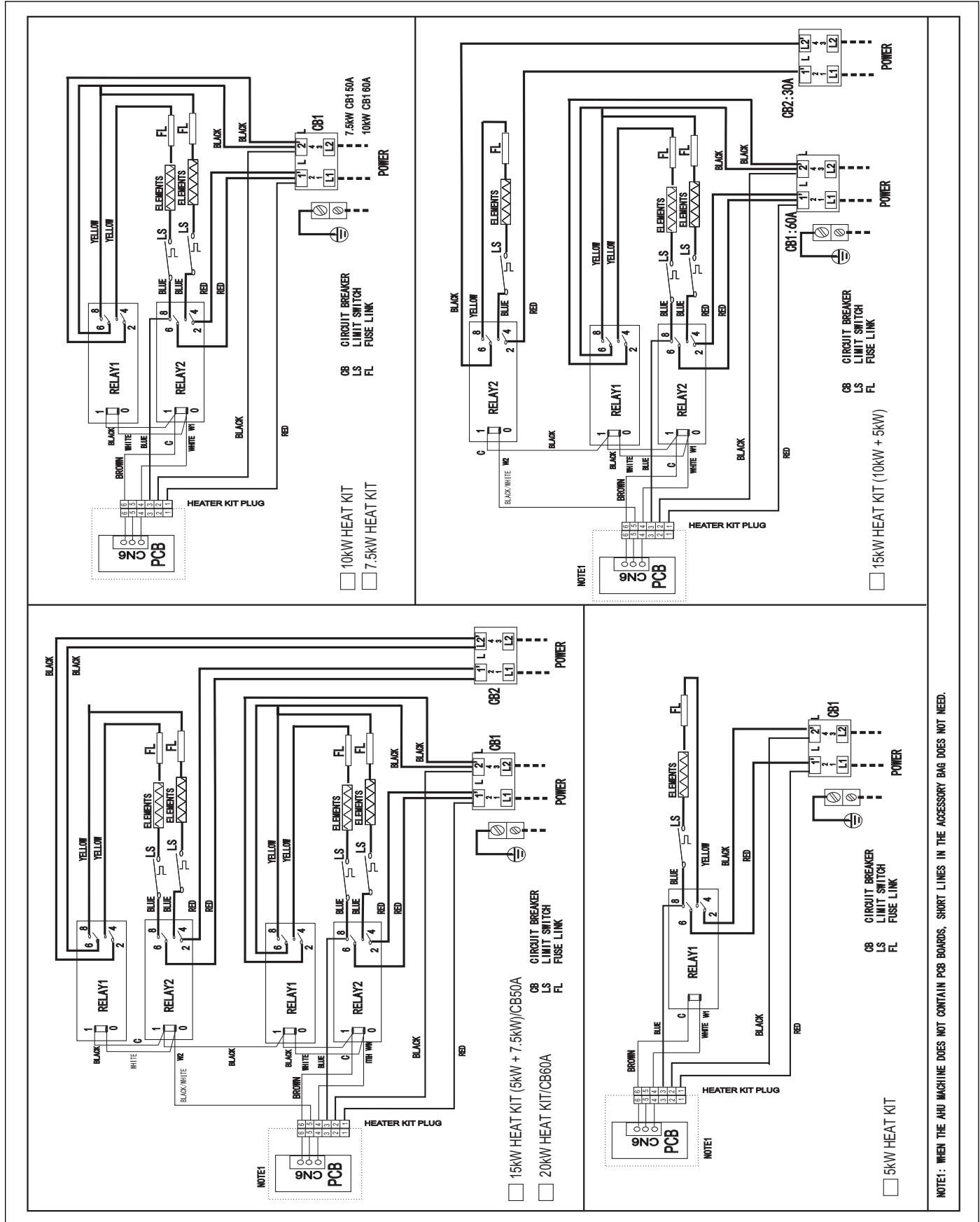

Figure 20

United States and Canada

**Bosch Thermotechnology Corp.
65 Grove Street
Watertown, MA 02472**

**Tel: 866-642-3198
Fax: 954-776-5529
www.boschheatingandcooling.com**