

ES Model

Water Source Heat Pump

2 to 6 ton

The ES Model features a two-stage scroll compressor, an ECM constant airflow blower motor and enhanced features that provide the best all around value in the highly competitive commercial market place.

ENHANCED	ES MODEL	PART LOAD	FULL LOAD
		UP TO 24.5	UP TO 18.7
		EER GLHP	COP WSHP
		UP TO 5.4	UP TO 5.0
		EER GLHP	COP WSHP



Made in
the U.S.A.



Commercial Sales Catalog
boscheatingandcooling.com



BOSCH
Invented for life

Table of Contents

MODEL NOMENCLATURE..... 2
CERTIFIED PERFORMANCE DATA 2
FHP EQUIPMENT 3
ABOUT BOSCH THERMOTECHNOLOGY CORP. IN NORTH AMERICA 3
ES MODEL 4
 Quality4
 Advantages of FHP Technology.....4
 Flexible Installation 4
 Quiet Operation 4
 Serviceability 4
ES MODEL 025-071..... 5
UNIT CONFIGURATIONS..... 5
FEATURES, FUNCTIONS AND BENEFITS 6
 Cabinet 6
 Unit Configurations 6
 Filter Racks and Unit Options 6
 Optional MERV-8 and MERV-13 Filters..... 6
 ECM Constant Airflow Fan Motor 6
 Blower Housing7
 Evaporator Coil.....7
 Refrigerant Circuit.....7
UNIT PROTECTION MODULE (UPM) 8
 UPM Control Board Features 8
DDC CONTROLS (OPTION)..... 9
 DDC Room Sensors..... 9
 DDC Zone Sensors10
ADDITIONAL FEATURES10
 Hanging Brackets.....10
 Water Connections.....10
ADDITIONAL OPTIONS 11
 Flow Proving Switch (DPS)..... 11
 Energy Management Switch (EMS) 11
 Two-Position Water Valve 11
 Hot Gas Reheat 11
 Refrigerant Flow Path 12
 Hot Gas Reheat Sequence of Operation - On/Off Control 12
 Sequence of Operation - Modulating Hot Gas Reheat (MHGRH) 12
 Hot Gas Reheat Control Options..... 12
 Special Considerations 12
 Low Temperature Well Water..... 13
 Indoor Pool Dehumidifying During Winter Months..... 13
 Psychrometric Chart 13
 Hot Gas Bypass 13
 Waterside Economizer & Common Waterside Economizer Applications..... 13
 Heat Recovery Package (Desuperheater) 14

ACCESSORIES14
 Thermostats.....14
 Hose Kits.....14
SYSTEMS15
 Water Source Cooling Tower/Boiler Systems15
 Geothermal Systems15
 Earth Coupling Options15
 Vertical Ground Loop System16
 Horizontal Ground Loop System16
TYPICAL HEAT PUMP OPERATION17
 Surface Water, Lake or Pond System 17
 Well Water System 17
 Cooling Mode 17
 Heating Mode 17
TYPICAL UNIT INSTALLATION18
 Water-to-Air Heat Pump Cycle – Cooling18
 Water-to-Air Heat Pump Cycle – Heating.....18
 Unit Location18
 Vertical Unit Installation.....18
 Horizontal Unit Installation19
 Ductwork and Sound
 Attenuation Considerations19
 Piping.....20
 Condensate Drain Piping 20
 Operating Limits – Cooling & Heating.....21
ANTIFREEZE CORRECTION DATA..... 22
WATERSIDE PRESSURE DROP 22
CAPACITY DATA 23-32
 ES025 – Part Load (600 CFM) 23
 ES025 – Full Load (900 CFM) 24
 ES035 – Part Load (1050 CFM)..... 25
 ES035 – Full Load (1225 CFM)..... 26
 ES049 – Part Load (1100 CFM)27
 ES049 – Full Load (1700 CFM) 28
 ES061 – Part Load (1500 CFM) 29
 ES061 – Full Load (2000 CFM)..... 30
 ES071 – Part Load (1600 CFM) 31
 ES071 – Full Load (2200 CFM) 32
ELECTRICAL DATA..... 33
 ECM Constant Airflow Motor 33
 Electric Heat Option..... 34
BLOWER MOTOR PERFORMANCE..... 35
 ECM Constant Air Flow (Variable Speed) 35
PHYSICAL DATA..... 36
HORIZONTAL CABINET CORNER WEIGHTS..... 37
VERTICAL UNIT DIMENSIONS..... 38
HORIZONTAL UNIT DIMENSIONS 39
COUNTERFLOW UNIT DIMENSIONS 40
GUIDE SPECIFICATIONS..... 41-45
NOTES..... 46

Model Nomenclature

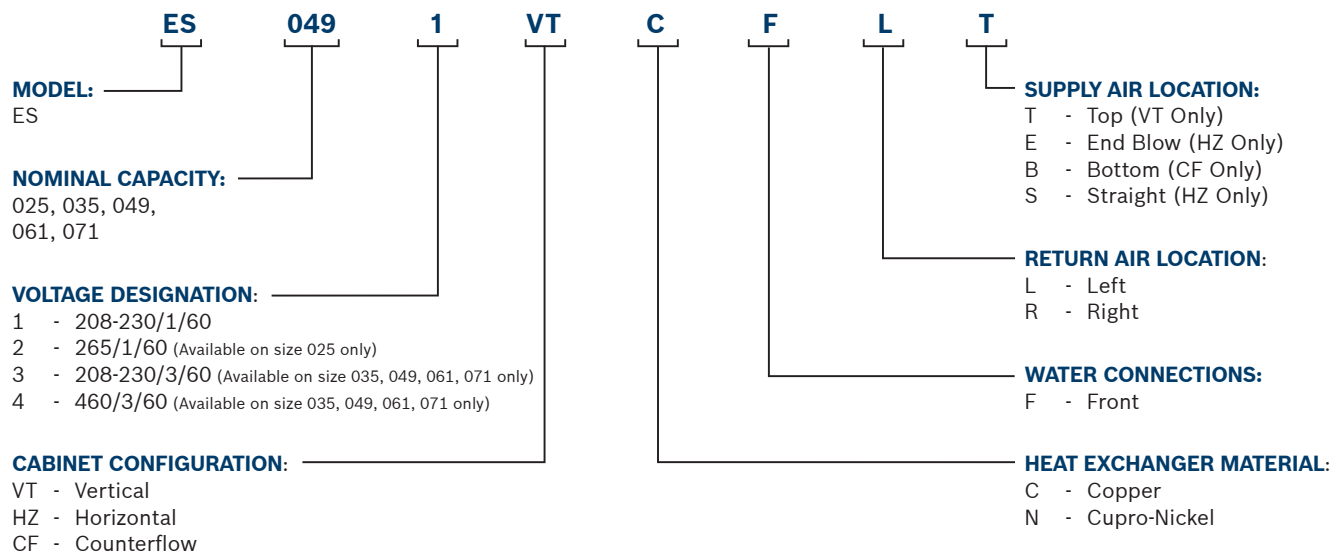

Certified Performance Data

AHRI/ANSI 13256-1 Performance Data														
Model	Load	GPM	Water Loop Heat Pump				Ground Water Loop Heat Pump				Ground Loop Heat Pump			
			Cooling 86°F		Heating 68°F		Cooling 86°F		Heating 68°F		Cooling 77°F		Heating 32°F	
			Capacity Btuh	EER Btuh/W	Capacity Btuh	COP	Capacity Btuh	EER Btuh/W	Capacity Btuh	COP	Capacity Btuh	EER Btuh/W	Capacity Btuh	COP
ES025	Part	6	18800	17.5	20500	5.1	21000	30.0	18000	4.6	20000	24.5	15500	4.0
	Full	6	26000	16.0	30000	5.0	29000	24.0	25000	4.6	27500	18.7	19000	3.8
ES035	Part	9	24000	17.0	27000	5.3	27000	28.0	22500	4.5	27000	24.5	20500	4.0
	Full	9	36000	14.6	43000	4.8	42000	21.6	36000	4.2	38000	17.2	28000	3.8
ES049	Part	12	34000	16.0	39000	5.4	38000	24.0	32000	4.6	36000	21.8	28500	4.0
	Full	12	48000	12.6	58000	4.8	54000	19.0	48000	4.2	49000	15.5	38000	3.6
ES061	Part	14	42000	17.0	48000	5.4	48000	26.0	40000	4.6	45000	23.5	36500	4.0
	Full	14	60000	14.0	72000	4.7	68000	19.7	61000	4.3	62000	15.7	49000	3.6
ES071	Part	18	51000	15.8	55000	4.4	57000	25.2	47000	4.0	56000	21.8	42000	3.7
	Full	18	72000	14.5	80000	4.5	77000	19.6	68000	4.2	74000	16.3	53000	3.5

Ratings based upon AHRI/ANSI 13256-1 with 1" disposable filter

Subject to change without prior notice.



FHP Equipment

Specializing in efficient green technology for commercial heating and cooling products. FHP products are one of the leading Geothermal and Water Source heat pumps in the market, which assures that you are buying a unit that you can trust. Bosch Thermotechnology Corp. is dedicated to providing highly efficient heating and cooling solutions to the private and public sectors.

Bosch Thermotechnology Corp. is always on the forefront of product development and innovative design to optimize the performance of FHP units. Our products are designed and manufactured to the highest quality, reflecting the no-compromise standards for which FHP and Bosch are renowned in order to provide our customers with the highest level of satisfaction and comfort. The variety of options, energy efficiency, and uncompromising quality of all FHP products makes them the ideal choice for the commercial new construction market and the ease of designing into tight retrofit spaces of buildings.

FHP's engineering efforts have been focused on providing a greener world for future generations. Faced with today's tough environmental challenges and with global warming, Bosch Thermotechnology Corp. is more committed than ever to develop solutions which utilize sustainable energy

sources in order to conserve our planet's resources. With our heat pumps, you not only will save money on energy bills but also help create a better world.

The ES Model water-to-air heat pump is the result of our almost 40+ years of research and development experience in the US heat pump market. It is the most flexible geothermal technology available today, designed for reliability, reducing installation costs and provide the building with comfort and the cost savings expected from FHP.

About Bosch Thermotechnology Corp. in North America

Bosch Thermotechnology Corp. is a leading source of high quality heating and cooling systems in North America. The company offers tankless, point-of-use water heaters, solar thermal systems, Bosch and Buderus conventional and condensing boilers, heat pump water heaters, Bosch and FHP geothermal heat pumps as well as controls and accessories for every product line. Bosch Thermotechnology Corp. is committed to reinventing energy efficiency by offering smart products that work together as integrated systems, which enhance quality of life in an ultra efficient and environmentally friendly manner.



Proven and Tested Technologies

FHP heat pumps are made by highly trained and skilled workers in the FHP factory based in Fort Lauderdale, Florida. They are manufactured with rigorous standards and factory testing ensuring trustworthy operation over the life of the unit. Bosch's ISO 9001 and ISO 14001 certified facilities provide consistent quality in every unit built.





2-Stage Scroll Compressor



Schrader Charging Valves for Servicing



Closed Cell Foam Insulation

ES Model

The ES 2-stage, water-to-air heat pumps offer high efficiency, value added features and dual capacity with standard features like a two speed scroll compressor and a ECM constant airflow fan motor, giving you the flexibility, performance and quiet operation needed to exceed the expectations of your clients.

Quality

The ES features as standard an anti-corrosive galvanized steel cabinet and stainless steel drain pan to ensure long life. To help prevent formicary corrosion, evaporator coils with tin-plated copper tubing are an option. Rigorous factory testing helps to ensure no hassles from the start while FHP's 40+ years of experience in designing heat pumps is your assurance of the highest quality product.

Advantages of FHP Technology

- ▶ Optimum comfort
- ▶ 2-stage capacity compressor
- ▶ Field configurable supply air
- ▶ Simple installation and operation
- ▶ Low installation costs
- ▶ Lower operating costs
- ▶ Flexibility in designing and installation
- ▶ Energy efficiency
- ▶ Space savings
- ▶ Superior quality
- ▶ Quiet operation



Flexible Installation

All units are available in horizontal, vertical, and counterflow configurations. Additional options of return air and supply air are offered as standard, providing configuration flexibility. To add to ease of installation, all horizontal units come standard with hanging bracket kits for suspending the unit from field supplied hanger rods. These kits include heavy-duty steel brackets and rubber grommets for sound and vibration isolation from the building structure.

Quiet Operation

The blower fan motor on this unit is extremely quiet by utilizing the ECM (electronically commutated motor) constant airflow type. The air flow can be field-adjusted to suit a specific installation and ensure your highest level of comfort.

Noise reduction is a critical consideration of the unit's design. All ES Models have a distinct floating base pan where the compressor is mounted on a heavy steel plate that rests on a high density rubber pad in the base of the unit. In addition, compressors are mounted on rubber grommets. This double isolation, distinct to FHP equipment, is standard in all ES models curtail vibration and noise transmission from the compressor to the unit structure resulting in exceptionally quiet operation. For additional sound attenuation in an application requiring the lowest sound levels, Bosch Thermotechnology Corp. offers a Quiet Package as an option available on all unit sizes.

Serviceability

All units are designed to be serviced from the front of the unit. Schrader valves for the high and low pressure gauges are standard, along with easily accessible electrical box components, allow diagnosing and servicing the unit a simple task. Insulated bulkheads in all ES Models separate the compressor section from the blower section, allowing the unit to be serviced easily during operation.

Sizable panels are removable to facilitate servicing of the unit. Separate electrical knockouts in the unit corner post allow for easy and safe routing of high and low voltage lines to the inside of the cabinet. These service friendly features benefit equipment owners with easier service access which saves time and money.

ES Model 025-071

- ▶ 5 Models from 2 through 6 tons
- ▶ Unit configurations – vertical, horizontal and counterflow

Vertical Configuration

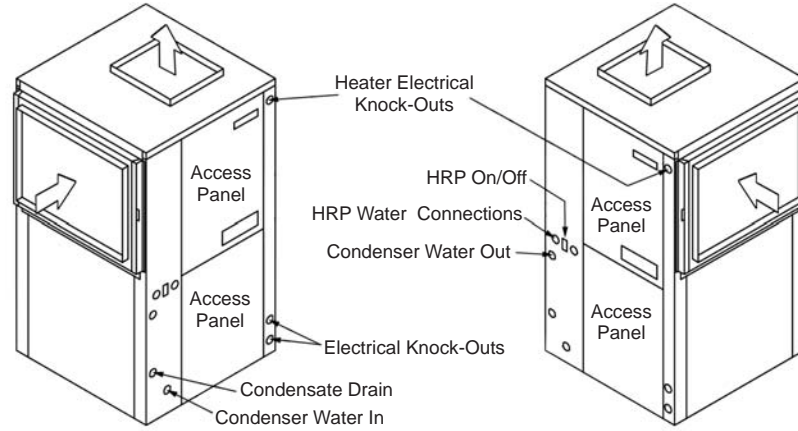

Figure 1

Left Hand Return Top Discharge FLT

Right Hand Return Top Discharge FRT

Horizontal Configuration

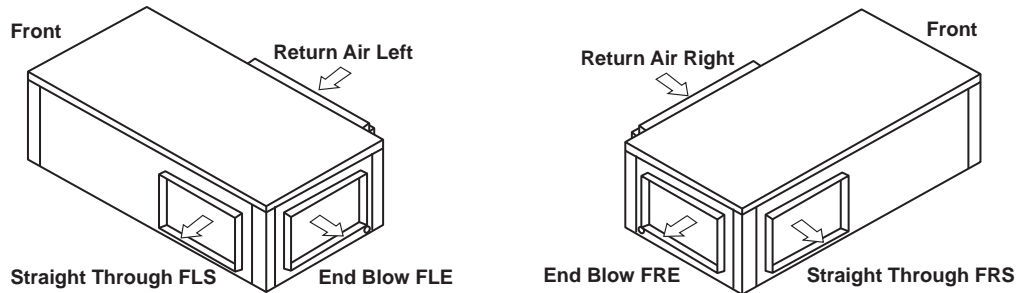

Figure 2

Straight Through FLS

End Blow FLE

End Blow FRE

Straight Through FRS

Counterflow Configuration

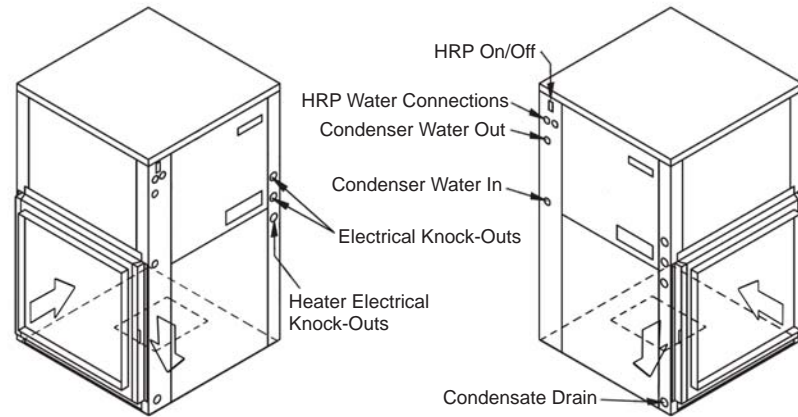

Figure 3

Left Hand Return Bottom Discharge FLB

Right Hand Return Bottom Discharge FRB



**MERV-8 or MERV-13
Filter Option**



**2" 4-Sided Filter
Rack Option**



**ECM Constant
Airflow Fan Motor**

Features, Functions and Benefits Cabinet

The ES Model cabinetry is constructed using heavy-gauge, galvanized steel. This type of steel provides superior corrosion protection for units installed indoors.

All interior surfaces are lined with ½" thick, 1.5lb/cu ft density micromat multi-density, coated fiberglass insulation for thermal insulation and acoustical attenuation. As an option, the closed cell foam insulation is available. This is a ½" thick high density, closed cell foam insulation which is fiber free, cleanable and further benefits indoor air quality. The closed cell foam insulation adds the benefit of quiet operation by reducing casing radiated noise levels from the unit.

The Quiet Package option includes a compressor blanket, offering optimum low sound levels.

Protection against corrosion is a feature with the ES Model. The stainless steel drain pan will last the lifetime of the unit while helping to resist corrosion and will avoid cracking and corrosion that may occur with inferior coated steel or plastic materials.



Standard



Optional

Filter Racks and Options

Four sided enclosed filter racks accommodating either a 1" or a 2" filter are standard on all ES Models. Four sided filter racks minimize unfiltered air from entering the unit allowing for cleaner, healthier air quality. Filter doors allow for easy routine maintenance and changing of the air filter. Integral to the filter rack is a 1" return duct collar that eliminates the need for field mounted duct collars. Units are shipped with a 1" MERV-5 construction filter.

MERV-8 and MERV-13 Filters

The optional MERV-8 or -13 filter is most advantageous for premium air filtration on commercial HVAC projects. High efficiency filtration is a cost-effective way of upgrading air quality while maintaining low pressure drop and sustaining long service life. These filters effectively remove up to 98% of airborne matter, such as fine particulates, bacteria, smoke, gases and allergens including dust mites, pollen, mold spores, dust and smog. MERV-8 and MERV-13 rated filters are a minimum requirement for EQ credits 3.1 and 5 on LEED projects. With the standard ECM constant airflow motor the ES is prepared to handle higher external pressure drops when utilizing the higher efficiency MERV-13 filters.

ECM Constant Airflow Fan Motor

The ES Model's high efficiency Electrically Commutated Motor (ECM), available in 1/3hp to 1hp, provides constant airflow in a wide static pressure range up to 1 in.w.g. Standard in all unit sizes, this motor is a great choice in high filtration applications. The motor has a soft start/stop feature, keeping noise to a minimum. Passive dehumidification can be achieved with the constant airflow ECM by reducing nominal airflow by 15%. This control feature lowers air coil temperature and prevents over-cooling of the space when in dehumidification mode. **IMPORTANT NOTE:** The constant airflow ECM requires a neutral wire in a 460V application.



1" Duct Flange



Blower Housing
(with Removable Inlet Ring)



2-Stage Scroll
Compressors



Tin-Plated Evaporator
Coil (Optional)

Blower Housing

Standard is a 1" supply air duct-flange connection facilitating the duct installation to the unit. Horizontal units are also field convertible from end discharge to straight through (and visa-versa).

A removable inlet ring is a standard feature of the blower housing on all unit sizes. The removable inlet ring helps facilitate motor removal without having to remove the fan housing from the cabinet. This allows less downtime while servicing the unit helping speed up recovery time and comfort levels.

Evaporator Coil

Air side refrigerant coils have copper tubes, aluminum fins and side plates to help prevent corrosion. The air coils are state-of-the-art, employing lanced fin and rifled tubing for maximum heat transfer giving the ES Model superb efficiencies. Large face areas result in lower face velocity reducing sound while ensuring high latent heat removal for maximum dehumidification in the cooling mode. Available as an option is our Tin-Plated evaporator coil protection; this will protect the evaporator coil from most forms of corrosive elements in the airstream and adds life expectancy to the entire system.

Refrigerant Circuit

ES Models are designed using the optimum combination of compressor, water and air coils to provide peak performance.

A heavy-duty 2-stage heat pump scroll compressor is used in all units. Scroll compressors are considered by many in the industry to be the best in durability and efficiency. Standard in all ES Models, this ensures that each unit will be equipped to give many years of trustworthy performance.

Refrigerant to water heat exchangers are coaxial tube-in-tube type providing a robust construction, ensuring years of trouble free operation. Coaxial coils are selected and designed for peak performance, offering the best combination of low water pressure drop and maximum heat transfer in both the cooling and heating modes. Standard coaxial coils have a copper interior water tube and a steel outer shell. Cupro-nickel coils are available as an excellent option for applications where the water is of low quality.

In geothermal applications where fluid temperatures can drop below the dew point of the surrounding air, the ES models are geothermal ready with insulation standard on the coaxial heat exchangers and refrigerant piping. A pilot operated four-way reversing valve in the refrigeration circuit allows the unit to operate in either the heating or cooling mode. All FHP units have the reversing valve energized in cooling mode, which allows the unit to fail to heating mode for building protection. This will ensure you are not left without heat in the middle of winter should the reversing valve coil fail.

Refrigerant flow to the air coil is controlled by a thermal expansion valve (TXV) and is standard in all ES Models. These TXV's are designed to vary the flow of refrigerant depending on the load. TXV's provide unit optimization and a more stable control over a wider range of operating conditions. ES Model are rated to withstand 600 PSIG working refrigerant pressure and 450 PSIG working water pressure. High and low pressure switches are factory installed in the refrigerant circuit, protecting the unit against high pressure conditions or loss of refrigerant charge.

Schrader service valves are standard on the high and low pressure lines of all units, allowing connection of gauges for service diagnostics and to evacuate, reclaim or recharge refrigerant into the system.



Coax Coil



Four-way Reversing Valve



UPM Control Board

Unit Protection Module (UPM)

Each ES Model is built in the factory with a Unit Protection Module (UPM) that controls the unit operation and monitors the safety controls that protect the unit. The UPM interfaces with the thermostat or human-machine interface (HMI). The main purpose of the UPM is to protect the compressor by monitoring the different states of switches and sensors. This module provides time delays and protects the unit against freezing of the water-to-refrigerant and air-to-refrigerant heat exchangers as well as condensate overflow. This level of protection helps provide the piece of mind that comes with offering an FHP product to the customer.

UPM Control Board Features

- ▶ **Condensate Overflow Protection** – The UPM controller continuously monitors the drain pan for high condensate water level, and if this exceeds normal operating levels, the compressor operation is interrupted to protect against drain pan overflow.
- ▶ **Anti-Short Cycle Timer** – 5 minute delay on break timer to prevent compressor short cycling.
- ▶ **Random Start** – Each controller has a unique random start delay ranging from 270 to 300 seconds after power is applied to the board. This will prevent the simultaneous start of multiple units after a power outage.
- ▶ **Low Pressure Bypass Timer** – The low pressure switch is bypassed for 120 seconds after a call for compressor operation to prevent nuisance low pressure lockouts during cold start-up in the heating mode.
- ▶ **Brownout/Surge/Power Interruption Protection** – Prevents compressor operation should the voltage drop below 10% of unit rated value. The unit will restart once the voltage is within tolerance and the random start has timed out.
- ▶ **Malfunction (Alarm) Output** – The controller has a set of contacts for remote fault indication. This can be either a steady output or can be set to pulse with the fault code. Two connections are available; one to provide a 24 volt output, the other to provide a dry contact.
- ▶ **Test Service Mode** – A dip switch setting is provided to reduce all time delay settings to 10 seconds maximum during troubleshooting for verification of unit operation.
- ▶ **LED Fault Indication** – Two LED indicators are provided as follows:
 - ▶ **Green:** Power LED indicates 18-30 VAC present at the board.
 - ▶ **Red:** Fault indicator with blink codes identifying the particular fault. This information is available via the malfunction (alarm) output contacts.
 - 1 Blink** - High Pressure
 - 2 Blinks** - Low Pressure
 - 3 Blinks** - High Pressure (2-stage)
 - 4 Blinks** - Low Pressure (2-stage)
 - 5 Blinks** - Low Fluid Temperature
 - 6 Blinks** - Condensate Overflow
 - 7 Blinks** - Brownout condition
- ▶ **Intelligent Reset** – If a fault condition is initiated, the 5 minute delay on break time period is initiated and the unit will restart after this delay expires. The UPM is configurable for either 2 or 4 fault occurrences before going into a hard lockout. The selection is made through a dip switch setting on the board. If the fault condition still exists or reoccurs twice or four times within one hour, the unit will go into a hard lockout and requires a manual lockout reset. A condensate overflow fault will, however, put the unit into a hard lockout immediately.
- ▶ **Lockout Reset** – A hard lockout can be reset by turning the unit thermostat off and then back on or by shutting off unit power at the circuit breaker. The method of reset is selectable by the dip switch on the board.



DDC Control Board



**RS Base
DDC Sensor**



**RS Plus
DDC Sensor**



**RS Pro
DDC Sensor**

DDC Controls (Option)

The optional factory mounted DDC Controller is preprogrammed and installed on the unit with the Unit Protection Module (UPM) to be job site ready. The unit will operate in a 100% stand-alone control mode or connect to a Building Automation System (BAS) using open protocols BACnet™, Modbus, N2 or LonWorks® (with an optional Lon card). Stand-alone DDC modules must use remote intelligent sensors and are to be programmed by the FHP BACview® controller only.

Zone temperatures, leaving air temperatures and water temperatures can be monitored from the central control computer and unit fault indication displayed.

Available inputs/outputs include:

- ▶ Discharge air temperature
- ▶ Leaving water temperature
- ▶ Fan run time
- ▶ Override time remaining
- ▶ Night setback status
- ▶ Percent of units cooling
- ▶ Percent of units heating
- ▶ Cooling set point
- ▶ Heating set point
- ▶ Status of all the alarms
- ▶ Space temperature
- ▶ Occupied heating and cooling set points
- ▶ Continuous or cycle fan during occupied mode
- ▶ Command for occupied or unoccupied mode
- ▶ Command for override of the unoccupied mode (unit resorts to occupied set points)
- ▶ Set point adjustment

DDC Room Sensors

To complement the controller, Bosch offers a line of intelligent space sensors, which provide precision measurement and communication capabilities in an attractive low profile enclosure. A hidden communications jack provides access to the HVAC control system for commissioning and maintenance.

Models available include:

- ▶ **The RS Pro** has a large LCD display and easy-to-use occupant controls for set point adjustment.
- ▶ **The RS Plus** offers a local set point adjustment and override to an occupied mode and LED indication of current status.
- ▶ **The RS Standard** which has no local temperature set point adjustment.

A BACview® hand held diagnostic tool is available to allow local access to display and modify user defined properties without any computer software. These space sensors will monitor, sense and provide local control for the room.



**BACview® Hand Held
Diagnostic Tool**



ZS Base
DDC Zone Sensor (ZS)



ZS Plus
DDC Zone Sensor (ZS)



ZS Pro
DDC Zone Sensor (ZS)

DDC Zone Sensors*

The Pro Zone Sensor (ZS) has an LCD screen that can display the current temperature and set temperature. It can also display relative humidity and CO₂ settings as well as their current readings. It comes with a button for additional information that can be displayed.

The Pro ZS can be ordered in any of the following combinations:

- ▶ Temperature setting only
- ▶ Temperature with relative humidity settings
- ▶ Temperature, relative humidity, and CO₂ settings

The Plus Zone Sensor (ZS) has a little different look to it. It has a occupied indicator that identifies the sensor to be operating in occupied conditions. It comes with a slide bar of for some manual temperature control in the occupied mode +/- setting can be adjusted during commissioning.

The Plus ZS can be ordered in any of the following combinations:

- ▶ Temperature setting only

The Base Zone Sensor (ZS) is limited to only sensing capabilities without local controllability. This zone sensor offers a basic look and blends into most decors.

The Base ZS can be ordered in any of the following combinations:

- ▶ Temperature sensor
- ▶ Temperature and relative humidity sensor

Additional Features

- ▶ 75VA transformer
- ▶ Dual refrigerant freeze sensors for airside and waterside
- ▶ Condensate overflow switch

Hanging Brackets

All horizontal units come standard with hanging bracket kits for suspending the unit from field supplied hanger rods. These kits include heavy-duty steel brackets and rubber grommets for sound and vibration isolation from the building structure.

Water Connections

All water connections are heavy-duty bronze FPT fittings securely fastened to the unit corner post. This allows connecting to a flexible hose kit without the use of a backup wrench making for easier, faster installation.



Water Connectors

* DDC Zone Sensors available through Applications Special Handling Sheet. When the Zone Sensors (ZS) are available as a standard option they will replace the Room Sensors (RS).

Additional Options

- ▶ 5, 10, 15, 20 kW electric heaters
- ▶ 100VA transformer
- ▶ Compressor monitor relay
- ▶ Fire alarm/dual power
- ▶ Pump/valve relay
- ▶ Disconnect switch
- ▶ Comfort alert module
- ▶ Automatic flow control valve*
- ▶ Wire for 208 volt
- ▶ Straight cooling unit
- ▶ Blower monitor relay
- ▶ LonWorks card

*Available as a special option through application engineering

Flow Proving Switch (DPS)

The function of the flow proving switch (or also referred to as a differential pressure switch) is to prevent or stop compressor operation should the water supply fail. This will prevent the unit from locking out on a safety requiring a manual reset to restart. This will minimize any unneeded service calls and allow for your unit to be protected. This optional control is internally mounted and factory installed. The switch is piped between the water entering and leaving connections. Should the pressure drop across the water-to-refrigerant heat exchanger fall below set value, the switch will open de-energizing the compressor. The blower operation will not be affected by this option.

Energy Management Switch (EMS)

This switch allows you to connect to an energy management system that can turn the unit off and on. Energy management systems are commonly used by individual commercial entities to monitor, measure, and control their electrical building loads. Energy management systems can be used to centrally control devices like HVAC units and lighting systems across multiple commercial applications sites.

Two-Position Water Valve

This special option comes from the factory internally mounted, available on all unit sizes and provides significant energy savings. The valve opens to allow 100% fluid flow through the coaxial heat exchanger only when there is a call for cooling or heating. When utilizing variable speed pumping, closing off fluid flow to the unit when there is no call for cooling or heating reduces system operating costs by reducing the speed of the primary loop pumps. The two-position motorized water valve is offered in a multiple protocols; BACnet™, Modbus and N2.

Hot Gas Reheat

Hot gas reheat (HGR) allows the user to not only control space temperature, but also humidity levels within the conditioned space. Excessive moisture in the space can promote mold growth leading to damage in the structure or interior surfaces, as well as reducing the air quality and creating an unhealthy environment.

Possible causes of excess humidity could be by the unit having to operate under a widely varying load, an oversized short cycling unit, a high percentage of unconditioned outside air being introduced into the space, a high latent load in the space or any location where humidity infiltration is a problem.

Typically a HGR unit can be controlled by wall mounted thermostat and humidistat device(s) to control temperature and humidity. Today another simple one-piece solution commonly marketed by third party vendors as a "thermidistat" (humidity/temperature) may be utilized as well as DDC Remote Sensor options. By utilizing a humidistat in addition to the thermostat, we are able to monitor the humidity levels in the space as well. The HGR option allows cooling and dehumidification to satisfy both the thermostat and humidistat while preventing over cooling of the space while in the dehumidification mode.

Once the thermostat reaches set point temperature and the humidity is above set point, the unit controller will energize the reheat valve operating the unit in hot gas reheat mode, first cooling and dehumidifying, then reheating the air using hot refrigerant gas before delivering it to the space, usually 2° to 5° F below room temperature. The unit is operating as a dehumidifier. By reheating the air along a constant sensible heat line, the relative humidity of the leaving air is reduced. This option offers significant energy savings over the traditional means of reheating air with electric heating coils.

The moisture removal capacity of a specific heat pump is determined by the unit latent capacity rating. A heat pump's latent capacity can be determined by reviewing the heat pump specification data sheets. Depending upon the entering water and air conditions, a total and sensible capacity can be interpolated from the data sheets. Subtracting sensible capacity from total capacity yields latent capacity. Dividing the latent capacity by 1069 (BTU/LB of water vapor at 80° DB and 67° WB) yields the amount of moisture removal in pounds per hour.

Refrigerant Flow Path

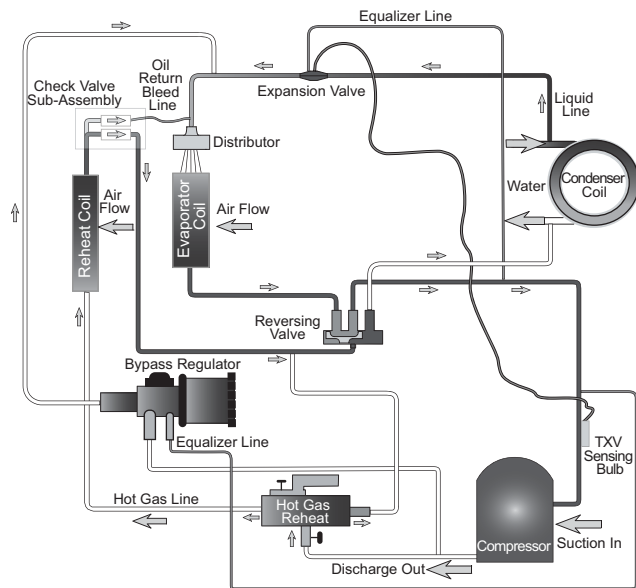

Figure 4

A hot gas reheat valve and a reheat coil are included in the refrigerant circuit. The refrigerant circuit in the cooling and heating mode is identical to a standard heat pump.

In the reheat mode, the compressor discharge gas is diverted through the reheat valve to the reheat coil which is located downstream of the cooling coil. The superheated refrigerant gas reheats the air leaving the cooling coil. The hot refrigerant gas then passes through the water-to-refrigerant coil where it is condensed to a liquid. From this point the rest of the cooling cycle is completed as in a regular heat pump. There are two check valves to prevent refrigerant flow into the reheat coil during standard cooling/heating cycles. A small copper bleeder line is connected to the outlet line of the reheat coil and between the expansion valve outlet and distributor to the air coil. This line is necessary to let any liquid/oil that may have migrated to the reheat coil during reheat to escape during standard cooling/heating modes (See Figure 4).

Hot Gas Reheat Sequence of Operation – On/Off Control

The sequence of operation in the cooling and heating mode is the same as a regular heat pump.

In the reheat mode, on a call from the humidistat, the reheat relay coil is energized through the “H” circuit. The cooling relay remains de-energized enabling the reheat solenoid. The blower relay, reversing valve and compressor contactor are energized through contacts on the reheat relay. (Note: The reheat mode always

operates in the cooling mode.) Should the temperature in the space increase above set point, the compressor terminal Y is energized, which will de-energize the reheat valve putting the unit into straight cooling mode. A call for cooling or heating will always take precedence over hot gas reheat.

Sequence of Operation - Modulating Hot Gas Reheat (MHGRH)

Modulating Hot Gas Reheat differs from On/Off in that the reheat function is always active. The purpose of MHGRH is to deliver air at or close to neutral conditions. Air is cooled and dehumidified by the cooling coil to around 55° F DB/54° F WB. The reheat coil raises the air stream temperature to a specified temperature (adjustable) and reduces relative humidity; delivering neutral air to the space. A sensor located in the supply air stream is set at the required leaving dry bulb temperature and will send a signal to the modulating hot gas reheat valve to direct the flow of hot gas to maintain that temperature. See psychrometric chart diagram (Figure 5). A typical application for this would be in treating 100% outside air. This air would be ducted directly into the space relieving the unit handling the zone of any outside air load. This can result in a smaller zone unit, less air flow and a savings in both initial and operating costs. Control of the hot gas modulation is by the wall mounted thermostat or the unit mounted DDC. A separate controller is used to control the unit itself.

Hot Gas Reheat Control Options

There are several ways to control heat pumps with hot gas reheat. You should choose the means that best suits your specific application. Please refer to the Hot Gas Reheat wiring diagrams for typical thermostat wiring. Most heat pump compatible thermostats in conjunction with a humidistat are acceptable for use, (Note: “O” output for reversing valve energized in cooling mode is required.) Combination thermostat/humidistat are also available.

Special Considerations

Some applications require special attention to maximize the performance of the hot gas reheat function:

- ▶ Low temperature well water
- ▶ Indoor pool dehumidifying during winter months (Re: heating mode)

Consult Bosch Thermotechnology Corp. for special application considerations.

Low Temperature Well Water

When low temperature well water is utilized as the water source (below 55° F), a means of establishing two flow rates, one for the cooling/reheat mode and one for heating mode is recommended. In the cooling mode at low entering water temperatures and standard flow rates, discharge pressures and corresponding discharge gas temperatures are relatively low. At these conditions, when the reheat mode is initiated, the low temperature discharge gas can reduce reheat capacity. A means to reduce the water flow rate and elevate the discharge pressure/ temperature in cooling/reheat mode should be provided. Conversely, at low entering water temperatures in the heating mode, system suction pressure is reduced causing a loss in heating capacity. A means of providing higher flow in the heating mode should be provided. The simplest way to accomplish the above is to install water regulating valves. For a unit requiring a field-installed water regulating valve, the optional factory installed Water Regulating Schrader Valve Assembly should be included with the unit to allow for proper control.

Indoor Pool Dehumidifying During Winter Months

It is important to remember that when in the reheat/ dehumidification mode the heat pump is cooling and reheating. A secondary means of heating the space during the dehumidification mode should be provided. The indoor space temperature should be kept at least 2° F above the pool water temperature. If this is not done the warm pool water attempts to heat the space and the humidity levels increase exponentially. The heat pump is normally sized to handle the design latent load moisture removal. A second heat pump or resistance heat should be provided to handle the structures shell loss load.



Protective tin-plating is highly recommended for all pool applications, due to the highly corrosive chemical environment.

Psychrometric Chart

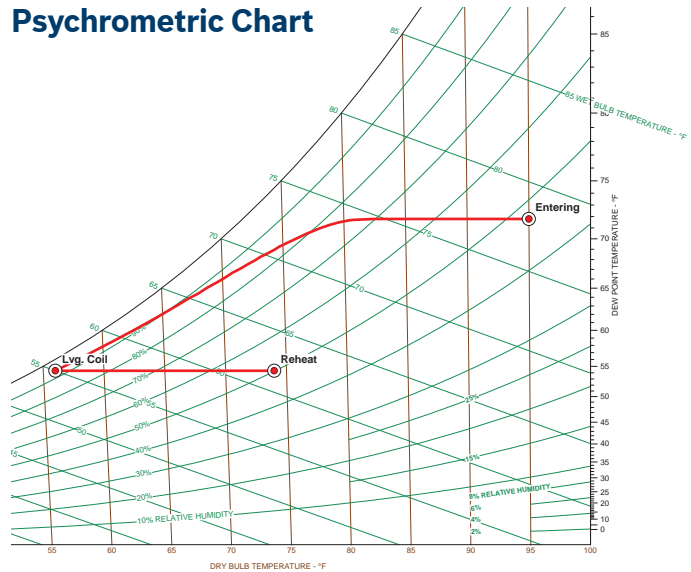

Figure 5

Hot Gas Bypass

The function of the hot gas bypass valve is to prevent icing of the air coil when the unit is operating at low load conditions. This situation could arise if the space experiences widely different heating and cooling loads or a unit sized for heating that has a much lower cooling load, for example a conference center. Without a hot gas bypass circuit the evaporating temperature will fall and ice could form on the coil restricting air flow and aggravating the situation. Eventually the coil could be totally blocked resulting in possible refrigerant liquid entering the compressor and failure of the system.

The hot gas bypass valve located in the compressor discharge line diverts hot gas to the inlet of the air coil. The valve is factory set to open when the evaporating pressure falls to 75 PSI and will modulate to prevent the pressure falling any lower. This setting is field adjustable and this set point may be adjusted as required.

Waterside Economizer

Examples of Waterside Economizer Applications

- ▶ **Commercial Application** where perimeter heating is taking place while core cooling is required. Perimeter heat pumps operating in the heating mode extract heat from the building loop, thus dropping the building loop fluid temperature. Internal core cooling requirements are usually high even in the winter months due to people, lighting, and equipment loads. The moderate temperature loop water circulated through a core heat pump’s waterside economizer coil



Thermostats



Hose Kit

can provide free-cooling without the use of mechanical cooling (Compressors). Also, in many areas code requires some type of economizer cycle. Waterside Economizers in lieu of air side economizers are an inexpensive way to satisfy code requirements in commercial applications.

► **Tenant Build Out Commercial Applications** where the central chilled water fluid loop serves as a individual zoned heat pump condenser water. In this application low temperature fluid is always available for free-cooling.

► Hot Water Heating or Chilled Water Cooling

The standard Waterside Economizer package is fully piped and wired internal to the unit. In special applications, the coil internal economizer piping an diverting valve can be designed out and removed, enabling the coil to be connected to an external hot or chilled fluid supply.

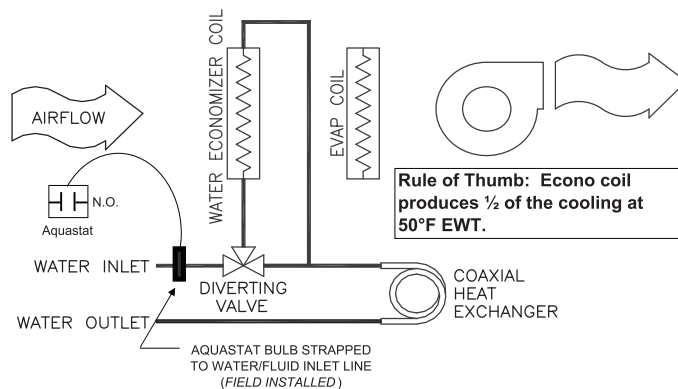

Figure 6

Heat Recovery Package (Desuperheater)

Hot water needs account for a large percentage of the energy a home or building consumes every year and ES Models customers know that our efficient technology can help support their hot water needs through the optional heat recovery package. With the Heat Recovery Package, you can have part of the system dedicated to your air conditioning and heating and another portion to supplement your current hot water heating system to meet the needs of the building.

Accessories

Thermostats

The ES Model control may be as simple as having a lone multi-stage thermostat or the unit may have a DDC controller integrated into the building management system. All external low voltage control wiring is made to the thermostat terminal located in the unit electrical box. Thermostats may be manual change over, auto change over, programmable or non-programmable depending on the requirements of the project. A full line of thermostats are available from Bosch.

Hose Kits

Hose kits are recommended between the unit and system loop piping. This will help eliminate the transmission of vibration and noise from the unit to the space. Hoses are fire rated fiber reinforced EPDM Stainless Steel braid hoses with swivel connections. Maximum working pressure 400 PSI for sizes 1/2" – 1" and 300 PSI for sizes 1 1/4" – 2". A variety of hose kits are available depending on the job requirement.

Kit 1 - Hoses only either 24" or 36" long.

Kit 2 - Hose kit 1 with ball valves on the supply and return hoses. Valves have P/T (pressure/temperature) ports to facilitate pressure and temperature readings.

Kit 3 - Hose kit 2 with an automatic flow control valve. The design flow rate is preset at the factory per the design conditions and will automatically limit the flow to this value. This will greatly facilitate balancing of the fluid loop and ensuring each unit gets the required flow.

Kit 4 - Hose kit 3 with a Y-strainer and blow down valve on the supply side. The filter screen is 20 mesh, 304 stainless steel to help prevent dirt and debris from entering the water coil.

Kit 5 - Hose kit 3 with a 24V, 2-position solenoid valve. This could be used to shut off flow to the unit when there is not a call for heating or cooling. A typical application would be with VFD pumping.

Kit 6 - Hose kit 4 with a 24V, 2-position solenoid valve.

Hose kit options are available in the accessories section of the BST selection software.

Systems

The ES Model may be used in a variety of different applications depending on the system design. An overview of tower/boiler and geothermal systems is given below. There could be several variations and combinations of these systems.

Cooling Tower/Boiler Systems



Water source heat pumps with cooling tower/boiler systems have been used for many years and are recognized as having a low installation cost and providing more energy efficient operation than most other systems on the market.

In a typical building, each office or space would receive its own heat pump. This ensures that the unit will independently satisfy the heating or cooling requirements for that space irrespective of the requirements of any other space. Unlike some other systems, this offers individual control and enhanced comfort in all areas.

All the units are connected to a common water loop containing, in addition to the heat pumps, a cooling tower, boiler, a primary and standby pump and a loop water temperature controller. In the summer cooling mode, the units are cooling and rejecting heat to the water loop. This heat is then rejected to the atmosphere through a cooling tower. In winter, heat is taken from the loop and, together with the compressor's heat of compression, used to heat the space. The heat removed from the loop is then replenished by the boiler. The loop water temperature controller

will keep the fluid within certain temperature limits typically 70°F in winter and 85°F in summer by cycling either the cooling tower or boiler operation.

In today's modern buildings the interior core usually has a net cooling requirement year round irrespective of the outside temperature. This is due to the internal heat gains from people, office equipment and lighting. The heat from heat pumps operating in cooling is rejected to the common water loop and is absorbed by heat pumps on the building's perimeter that are in the heating mode. In effect the system is transferring energy around the building areas from where it is in excess to those areas where it is needed. In many instances we find a balanced system where the heat generated in the interior space is sufficient to heat the perimeter, resulting in neither the cooling tower nor boiler operating. This concept, unique to a water source system, provides the most energy efficient system on the market.

Geothermal Systems

The earth has a tremendous capacity of storing thermal energy, which can be utilized to heat or cool a building.

A geothermal system offers all the benefits of a cooling tower and boiler system with the additional advantage of having overall greater energy efficiency. As the cost of energy increases, geothermal installations are becoming the system of choice by developers and design engineers.

There are several alternative methods of utilizing the energy contained in a geothermal system, giving the design engineer several options for selecting the one that is right for a particular application.

Earth Coupling Options

Ground Loop Systems (Closed Loop)

Lengths of high density polyethylene piping are buried in the earth either in vertical bore holes or horizontal trenches depending on the space available.

Fluid from the loop inside the building circulates through these pipes either rejecting heat to the ground when there is a net cooling requirement or absorbing heat from the ground when heating is the dominant requirement.

The temperature of the earth below 6 feet is relatively constant and is not affected by the ambient temperature. For this reason, the ground temperature is cooler than the summer ambient and warmer than the winter ambient in most regions. Geothermal systems are able to operate effectively in extreme ambient conditions exceeding 100°F in summer and -30°F in winter. This is one of the reasons why geothermal systems have such an advantage over other systems. An additional advantage is that no fossil fuels are used, reducing the carbon emission of the building.

Even in areas which are cooling or heating dominant a hybrid system can be used with a downsized cooling tower or boiler. This system will reduce the installed cost significantly with only a modest impact on overall operating efficiency.

Geothermal systems may cost more to install but the savings in energy and low maintenance costs more than off set this with payback times typically five years or even less.

Vertical Ground Loop System



This method is used mainly in commercial buildings or where space for a loop field is limited. Vertical holes 100 to 400 feet deep are drilled in the ground, and a single loop of high density polyethylene pipe with a U-tube at the bottom is installed. The bore hole is then sealed with grout to ensure good contact for heat transfer with the soil. The size of the project will determine how many bore holes are required. The vertical ground loops are then connected to a horizontal header pipe that carries fluid to the building and circulated to each heat pump. The Earth's temperature is stable below the surface which is an advantage for this system and provides for the greater efficiency. Vertical ground loop fields may be located under buildings or parking lots. The life expectancy is in excess of 50 years.

Horizontal Ground Loop System



This type is cost effective on smaller projects or where there is sufficient space for the loop field. Trenches, three to six feet deep are dug in which a series of high density polyethylene pipes are laid. These loops are manifolded and connected to the loop inside the building which feeds the heat pumps. The fluid is then circulated, absorbing or rejecting heat to the earth depending on the requirement for heating or cooling.

Typical Heat Pump System

Surface Water, Lake or Pond System



This type of design is economical when a project is located near a body of water. Fluid circulates through polyethylene piping in a closed system, just as it does through ground loops, but in this case, underwater. The pipes may be coiled in a slinky to fit more surface into a given amount of space. The lake needs to be a minimum size and depth depending on the building load. Lake loops have no adverse impact on the aquatic system. Specialized lake heat exchangers are also available for this application. New technology is emerging for stainless steel and titanium heat exchangers.

Well Water System



This type of installation is only possible if there is sufficient ground water available in a well. The water must be of good quality. Local codes may limit the use of this system in certain areas. The arrangement is referred to as an open system which means that water is pumped directly from the source into the geothermal unit and then discharged either into a return well or a body of water. The water quality is unaffected other than a change in the temperature. Refer to the installation manuals for water quality guidelines. Field-installed water regulating valves may be required.

Typical Heat Pump Operation

Cooling Mode

In the cooling mode, hot high pressure refrigerant gas is pumped from the compressor to the water-to-refrigerant heat exchanger via the reversing valve. Water, or an anti-freeze solution, flowing through the water-to-refrigerant heat exchanger transfers heat from the refrigerant to the fluid raising the fluid temperature while condensing the hot gas into a liquid. This liquid refrigerant then flows through a metering device, where the refrigerant is expanded to a cold liquid, to the air-to-refrigerant heat exchanger coil.

The air-to-refrigerant heat exchanger cools and dehumidifies air by evaporating the liquid refrigerant. The cooling cycle is completed when the refrigerant flows as a low pressure gas through the reversing valve and back to the suction side of the compressor. Cool dehumidified air is circulated to the space maintaining comfort conditions.

Heating Mode

During the heating mode, the high pressure refrigerant gas is pumped from the compressor to the air-to-refrigerant heat exchanger coil via the reversing valve. In the air-to-refrigerant heat exchanger coil, the heat is removed by the air that passes over the coil surface, and the hot gas condenses into a liquid.

The heated air is ducted to the space and provides heating for the building. The refrigerant liquid then flows through a metering device to the water-to-refrigerant heat exchanger. Water, or an anti-freeze solution, circulates through this heat exchanger and is cooled by the evaporating refrigerant which evaporates into a gas. The heating cycle is completed when the refrigerant flows as a low pressure gas through the reversing valve and back to the suction side of the compressor.

Typical Unit Installation

Water-to-Air Heat Pump Cycle – Cooling

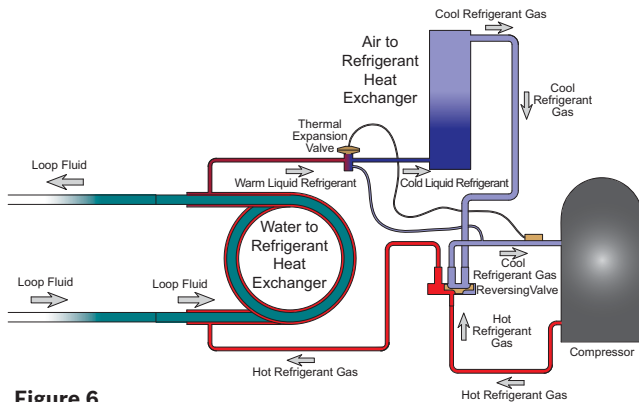

Figure 6

Water-to-Air Heat Pump Cycle – Heating

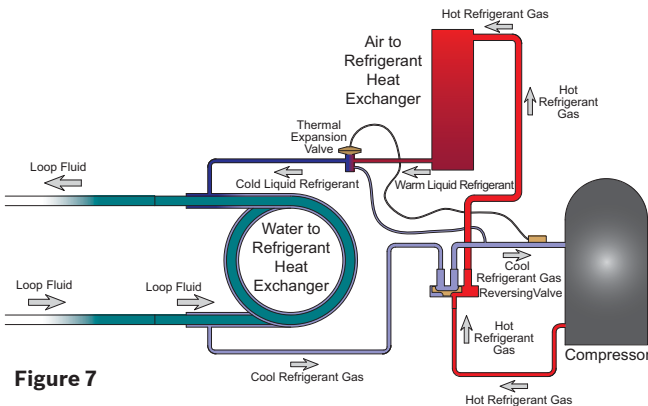

Figure 7

Vertical Unit Installation

Vertical units are normally installed in a closet or mechanical plant room. If installed in a closet or other confined space, ensure adequate space for return air to the unit. Sufficient space must be provided for filter replacement and access to the compressor and blower for service.

Units should be set on a piece of rubber, neoprene or other vibration absorbing material at least 1/3" to 1/2" thick. The pad should extend 3/4" over the entire base of the unit. Avoid direct line of sight to the unit. Install a sound baffle over any door that has a return air grille.

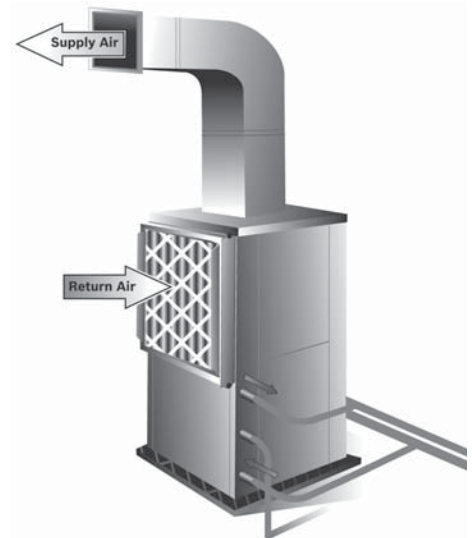

Figure 8

Unit Location

Any mechanical device will, at some point in time require servicing and repair.

With this in mind sufficient space must be provided around the unit for service personnel to perform maintenance or repair.

Units are not designed for outdoor installation. Avoid locations where the unit may be exposed to freezing conditions or where the humidity levels could cause condensation on the unit panels, for example, when exposed to outdoor ambient conditions.



Typical Unit Installation

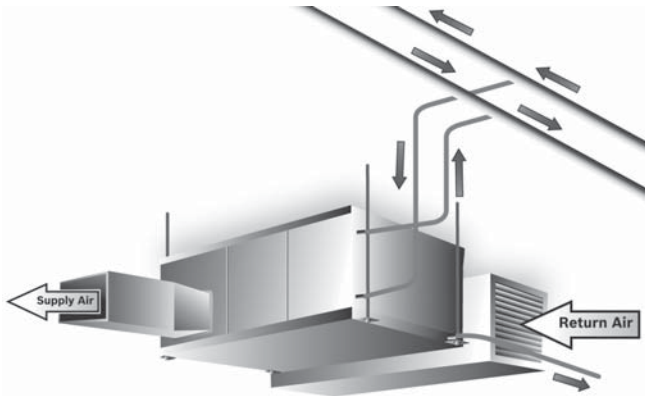

Figure 9

Horizontal Unit Installation

Horizontal units are typically suspended above the ceiling by four (field supplied) 3/8" threaded rods fastened to the unit by the factory supplied hanger bracket kits. The kits include rubber isolators to help prevent transmission of vibration and noise to the building structure. Units should be located directly below a structural member, so that it is securely anchored.

A horizontal unit should be positioned to allow for removal of the filters and access panels. Allow at least 18" clearance on each side of the unit for service and 36" in front of the unit for maintenance access. The filter needs to be slid out and sufficient space must be provided to allow this.

Do not install the unit above any piping or electrical raceways. The unit should be able to be removed to the floor without major rearrangement of other mechanical or ceiling components.

Consideration needs to be made as to the location of the units. Avoid installing units directly above occupied spaces (e.g. above office desks or classrooms). This will minimize possible disruption to the occupants if maintenance or service is required as well as keeping a potential source of noise out of the area. If possible, units should be installed above the hallway drop ceiling in schools, and the supply and return air is routed directly into classrooms. Local code may require fire dampers to be used in this application.

Ductwork and Sound Attenuation Considerations

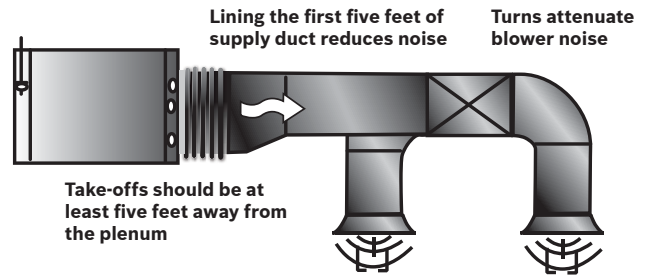

Supply Air Ducting

Figure 10

Sound is becoming an increasingly important factor in all HVAC installations. The ES Model has been designed to minimize sound, but sound acoustical design plays an important part of the sound level in the space.

Most of the problems associated with HVAC generated sound can be avoided by paying close attention to duct design and equipment placement.

A discharge flange is provided on all horizontal unit models for fastening of ductwork. We recommend using a flexible collar between the discharge flange and the duct transformation to reduce vibration transmission from the cabinet and to simplify disconnection of the unit from the ceiling ductwork.

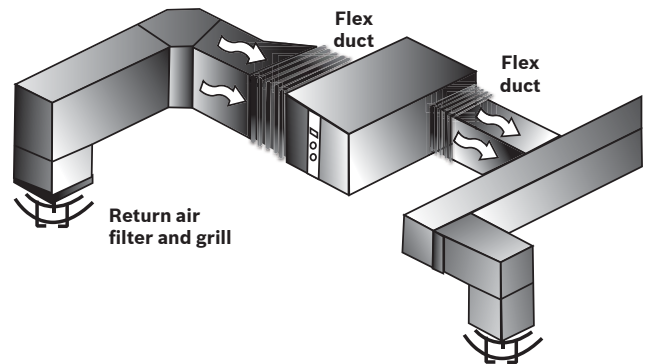

Return Air Ducting

Figure 11

Return air to the unit could be either free return or ducted. The filter rack is provided with a 1" flange should a ducted return be used. We recommend using a flexible collar between the return flange and the duct transformation to reduce vibration transmission from the cabinet and to simplify disconnection of the unit from the ductwork.

Sound is transmitted down the ductwork and it is important to avoid direct line of sight between the unit and the space, both on the return or supply side. To accomplish this, design the duct runs with two 90° turns.

As a general recommendation, duct interiors should have an acoustic / thermal lining of least 1/2" thick over the entire duct run or a minimum of the first 5 feet of the supply trunk.

Line the last five diameters of duct before each outlet with a one-inch thick sound blanket. Line elbows and transition pieces, as well as a short distance upstream and downstream of the fittings.

Elbows, tees and dampers can create turbulence or distortion in the airflow. Using aerodynamic fittings will help in reducing this effect. Place a straight length of duct, 5 to 10 times the duct width, before the next fitting to smooth out airflow.

Diffusers that are located in the bottom of a trunk duct can also produce noise. Balancing dampers should be located several duct widths upstream from an air outlet. Ductwork should be mounted and supported using isolation devices that absorb vibration.

Applications such as Hotel, Motel, Dormitory or Nursing Home that use a single duct discharge are susceptible to noise. These applications typically have low static pressures and short duct lengths. In these applications the discharge duct must be fully lined and have a square elbow without turning vanes. A velocity not exceeding 500 to 600 fpm is recommended. Return air for these applications should enter through a sidewall grille and route up the stud space to a ceiling plenum.

For horizontal heat pumps mounted in the ceiling plenum, an insulated return plenum is sometimes placed at the return air opening to further attenuate line-of-sight sound transmission through return openings.

In highly sound sensitive locations, the designer should consider utilizing a split system from Bosch Thermotechnology Corp. In this design, the condensing section is located away from the sound sensitive area. Refrigerant piping connects the FHP air unit in the sound sensitive area to the FHP condensing section, which contains the compressor and coaxial water coil. Ask your FHP representative for information.

Piping

The water loop system is typically designed using a "reverse return" piping system which includes a flow control device so that flow requirements are met for each zone. A high pressure stainless steel flexible hose kit is recommended to connect the unit to the building's hard piping and acts as a sound attenuator for both the unit operating noise and hydraulic pumping noise. One end of the hose has a swivel fitting to facilitate removal of the unit for replacement or service.

Hose kits come in several configurations, but in all cases should include supply and return shutoff ball valves to allow removal of a unit without the need to shut down the entire heat pump system. The hose kit may contain either a manual or automatic flow control that may be preset to ensure correct water flow to the unit.

Other components of the hose kit may be a Y-strainer to prevent dirt from fouling the water coil. A blow down valve is recommended with the Y-strainer.

Many installations today use variable frequency drives on the water loop pump as an energy saving measure. This requires the flow to the unit be shut off when it is not operating. This can be accomplished by including a 2-way solenoid valve in the hose kit, which is field wired to open when the compressor is energized. A factory supplied, internal 2-position solenoid valve is also an option.

Pressure / Temperature ports should be included in these fittings to allow the service technician to measure water flow and temperatures when checking unit operation.

Condensate Drain Piping

Condensate piping can be made of steel, copper or PVC pipe. In most cases, PVC pipe eliminates the need to wrap insulation around the pipe to prevent sweating.

A 3/4" FPT condensate drain connection is installed in the unit. The condensate piping must be trapped at the unit and pitched away from the unit not less than 1/4" per foot. A vent is required after the trap so that the condensate will drain away from the unit. The vent can also act as a cleanout if the trap becomes clogged. The condensate drain should not be directly piped to a drain/waste/vent stack. See local codes for the correct application of condensate piping to drains.

Operating Limits

The ES Models are capable of operating over a wide range of conditions. For operation in a geothermal application or any other installation where the loop fluid temperature may drop below the ambient dew point, the extended range option is recommended. This consists of additional insulation on the piping to prevent condensation.

- ▶ Maximum and minimum fluid conditions are at unit rated flow rate.
- ▶ Maximum and minimum operating limits may not be combined. If one value is at either maximum or minimum, the other two should be at normal operating range.
- ▶ Entering fluid temperatures below 45°F in the heating mode require antifreeze.

Equipment Selection

To ensure that you get the optimal performance from your FHP heat pump it is important that they be selected accurately to match your design conditions.

Prior to making equipment selections the zone conditions need to be determined. Bosch Thermotechnology Corp. recommends using a building load program to determine the heating and cooling loads.

The catalog provides a wide range of entering air and water conditions that will meet most applications. The unit performance can be determined by referring to the data tables from page 23 to 32.

Our Bosch Select Tools Selection Software (BST) is designed to provide you with a fast and accurate selection based on your specific conditions. This software is available through the commercial website. You may click on the BST link and request an account.

Unit Operating Limits—ES Model

Operating Limits – Cooling & Heating	Standard Unit	Extended Range Option
Cooling		
Minimum ambient air temperature °F	50	50
Maximum ambient air temperature °F	100	100
Minimum evaporator entering air db/wb °F	68/57	68/57
Rated air coil entering air db/wb °F	80/67	80/67
Maximum evaporator entering air db/wb °F	95/85	95/85
Minimum water coil entering fluid temperature °F	70	40
Water loop typical coil entering fluid range temperature °F	70/90	70/90
Maximum water coil entering fluid temperature °F	110	110
Heating		
Minimum ambient air temperature °F	50	40
Maximum ambient air temperature °F	100	85
Minimum evaporator entering air db °F	50	50
Rated air coil entering air °F	68	68
Maximum evaporator entering air db °F	80	80
Normal water coil entering fluid range °F	50-80	25-80
Minimum water coil entering Fluid °F	50	20*

*Antifreeze solution is required at these fluid temperatures.

Antifreeze Correction Data

Antifreeze Correction							
Antifreeze Type	Antifreeze %	Cooling			Heating		WPD Correction Factor EWT 30 °F
		Avg. Water Temp 90 °F			Avg. Water Temp 30 °F		
		Total Cap.	Sens. Cap	Power	Htg. Cap	Power	
Water	0	1.000	1.000	1.000	1.000	1.000	1.000
Propylene Glycol	5	0.997	0.997	1.004	0.989	0.997	1.060
	10	0.994	0.994	1.006	0.986	0.995	1.125
	15	0.990	0.990	1.009	0.978	0.988	1.190
	25	0.983	0.983	1.016	0.960	0.979	1.300
Methanol	5	0.997	0.997	1.003	0.990	0.997	1.060
	10	0.996	0.996	1.005	0.979	0.993	1.100
	15	0.994	0.994	1.008	0.970	0.990	1.140
Ethanol	5	0.998	0.998	1.002	0.981	0.994	1.160
	10	0.996	0.996	1.004	0.960	0.988	1.230
	15	0.992	0.992	1.006	0.944	0.983	1.280
	25	0.986	0.986	1.009	0.917	0.974	1.400
Ethylene Glycol	5	0.997	0.997	1.003	0.993	0.998	1.060
	10	0.995	0.995	1.004	0.986	0.996	1.120
	15	0.992	0.992	1.005	0.980	0.993	1.190
	25	0.988	0.988	1.009	0.970	0.990	1.330
	30	0.985	0.985	1.012	0.965	0.987	1.400

Waterside Pressure Drop

Model	GPM	Pressure Drop (PSIG)	Pressure Drop (ft of H2O)
ES025	4.0	0.90	2.07
	5.0	1.34	3.10
	6.0	1.86	4.30
	7.0	2.46	5.68
	8.0	3.13	7.22
ES035	6.0	1.86	4.30
	7.5	2.78	6.43
	9.0	3.86	8.93
	10.5	5.10	11.8
	12.0	6.49	15.0
ES049	8.0	2.12	4.90
	10.0	3.17	7.32
	12.0	4.41	10.16
	14.0	5.81	13.41
	16.0	7.39	17.06
ES061	9.0	1.85	4.28
	11.5	2.88	6.65
	14.0	4.10	9.48
	16.5	5.52	12.74
	19.0	7.11	16.4
ES071	12.0	3.23	7.45
	15.0	4.82	11.13
	18.0	6.70	15.45
	21.0	8.84	20.39
	24.0	11.24	25.93

NOTE: Based on pure water at 70°F

Capacity Data

ES025 – Part Load (600 CFM)

Cooling									Heating													
Entering Fluid Temp (°F)	Water Flow (GPM)	Pressure Drop PSI (FOH)	Entering Air Temp (db/wb) °F	Total Capacity (MBTUH)	Sensible Capacity (MBTUH)	Heat of Rejection (MBTUH)	Power Input (kW)	EER	Entering Fluid Temp (°F)	Pressure Drop PSI (FOH)	Entering Air Temp (°F)	Total Capacity (MBTUH)	Heat of Absorption (MBTUH)	Power Input (kW)	COP							
50	3	0.6 (1.3)	75/63	21.6	15.9	24.1	0.78	27.9	30	0.7 (1.5)	60	13.5	10.3	0.98	4.0							
			80/67	23.1	16.4	25.7	0.78	29.5				70	13.0	9.8	1.12	3.4						
			85/71	24.8	16.8	27.4	0.79	31.3				80	12.8	8.7	1.27	3.0						
	4	1.0 (2.2)	75/63	22.0	16.1	24.4	0.73	30.0			60	1.1 (2.5)	60	13.7	10.6	0.98	4.1					
			80/67	23.6	16.6	26.0	0.74	32.0					70	13.4	9.9	1.12	3.5					
			85/71	25.2	17.0	27.7	0.75	33.9					80	13.2	9.0	1.27	3.0					
	6	2.0 (4.6)	75/63	22.4	16.2	24.6	0.69	32.3			60	2.2 (5.1)	60	14.2	11.0	0.99	4.2					
			80/67	24.0	16.8	26.3	0.70	34.6					70	13.7	10.3	1.12	3.6					
			85/71	25.7	17.2	28.0	0.70	36.9					80	13.4	9.4	1.28	3.1					
60	3	0.6 (1.3)	75/63	20.6	15.5	23.4	0.90	23.0	40	0.6 (1.4)	60	15.5	12.4	1.00	4.5							
			80/67	22.0	16.0	24.9	0.91	24.3				70	15.2	11.5	1.15	3.9						
			85/71	23.6	16.4	26.5	0.92	25.8				80	14.7	10.5	1.30	3.3						
	4	0.9 (2.1)	75/63	20.9	15.6	23.6	0.86	24.5			60	1.0 (2.4)	60	15.9	12.7	1.01	4.6					
			80/67	22.4	16.1	25.2	0.86	26.0					70	15.5	11.8	1.15	3.9					
			85/71	24.0	16.5	26.8	0.87	27.7					80	15.1	11.0	1.31	3.4					
	6	1.9 (4.4)	75/63	21.3	15.8	23.9	0.82	26.2			60	2.1 (4.9)	60	16.5	13.2	1.02	4.7					
			80/67	22.8	16.3	25.5	0.82	27.9					70	16.0	12.2	1.16	4.0					
			85/71	24.5	16.7	27.2	0.82	29.9					80	15.6	11.2	1.31	3.5					
70	3	0.5 (1.2)	75/63	19.5	15.0	22.6	1.03	19.0	50	0.6 (1.4)	60	17.8	14.5	1.04	5.0							
			80/67	20.9	15.5	24.1	1.04	20.2				70	17.4	13.8	1.18	4.3						
			85/71	22.3	16.0	25.6	1.05	21.3				80	17.1	12.7	1.34	3.7						
	4	0.9 (2.1)	75/63	19.8	15.1	22.9	0.99	20.1			60	1.0 (2.3)	60	18.3	15.0	1.05	5.1					
			80/67	21.3	15.6	24.4	0.99	21.5					70	17.9	14.1	1.19	4.4					
			85/71	22.7	16.1	25.9	1.00	22.7					80	17.3	12.9	1.35	3.8					
	6	1.9 (4.3)	75/63	20.1	15.3	23.1	0.95	21.3			60	2.0 (4.7)	60	19.0	15.8	1.06	5.3					
			80/67	21.6	15.8	24.6	0.95	22.8					70	18.4	14.6	1.20	4.5					
			85/71	23.2	16.2	26.3	0.95	24.4					80	17.9	13.6	1.36	3.9					
80	3	0.5 (1.2)	75/63	18.4	14.5	21.9	1.17	15.7	60	0.6 (1.3)	60	20.4	16.2	1.08	5.6							
			80/67	19.7	15.0	23.3	1.18	16.7				70	18.8	16.1	1.19	4.6						
			85/71	21.0	15.5	24.7	1.19	17.7				80	19.3	14.8	1.38	4.1						
	4	0.9 (2)	75/63	18.7	14.6	22.1	1.13	16.6			60	1.0 (2.2)	60	20.9	17.6	1.09	5.6					
			80/67	20.0	15.2	23.5	1.14	17.6					70	20.5	16.3	1.24	4.9					
			85/71	21.5	15.6	25.0	1.14	18.8					80	19.6	15.2	1.39	4.1					
	6	1.8 (4.1)	75/63	19.0	14.8	22.3	1.09	17.5			60	2.0 (4.6)	60	21.7	18.4	1.10	5.8					
			80/67	20.4	15.3	23.8	1.09	18.7					70	21.1	16.9	1.25	5.0					
			85/71	21.9	15.8	25.3	1.10	20.0					80	20.3	15.6	1.40	4.2					
85	3	0.5 (1.2)	75/63	17.8	14.3	21.6	1.25	14.3	70	0.6 (1.3)	60	23.1	20.2	1.13	6.0							
			80/67	19.1	14.8	22.9	1.26	15.2				70	22.4	18.3	1.27	5.1						
			85/71	20.4	15.3	24.3	1.27	16.1				80	20.5	17.4	1.39	4.3						
	4	0.9 (2)	75/63	18.1	14.4	21.8	1.21	15.0			60	0.9 (2.1)	60	23.8	20.4	1.14	6.1					
			80/67	19.4	14.9	23.1	1.21	16.0					70	22.9	18.9	1.29	5.2					
			85/71	20.8	15.4	24.6	1.22	17.1					80	22.0	17.3	1.44	4.5					
	6	1.8 (4.1)	75/63	18.4	14.5	22.0	1.17	15.8			60	1.9 (4.4)	60	24.5	20.8	1.15	6.2					
			80/67	19.8	15.1	23.4	1.17	17.0					70	23.7	19.7	1.30	5.3					
			85/71	21.2	15.5	24.9	1.17	18.1					80	22.9	18.0	1.45	4.6					
90	3	0.5 (1.2)	75/63	17.2	14.0	21.2	1.33	13.0	80	0.5 (1.2)	60	25.7	22.8	1.18	6.4							
			80/67	18.4	14.6	22.5	1.34	13.8				70	25.0	21.0	1.33	5.5						
			85/71	19.7	15.0	23.9	1.35	14.7				80	24.1	19.8	1.48	4.8						
	4	0.8 (1.9)	75/63	17.5	14.2	21.4	1.29	13.6			60	0.9 (2.1)	60	26.8	23.4	1.19	6.6					
			80/67	18.8	14.7	22.7	1.29	14.6					70	25.6	21.8	1.34	5.6					
			85/71	20.2	15.1	24.2	1.30	15.6					80	24.7	20.0	1.49	4.9					
	6	1.7 (4)	75/63	17.8	14.3	21.6	1.25	14.3			60	1.9 (4.3)	60	27.5	24.3	1.21	6.6					
			80/67	19.2	14.8	23.0	1.25	15.4					70	26.5	22.4	1.36	5.7					
			85/71	20.5	15.3	24.4	1.25	16.4					80	25.2	20.3	1.50	4.9					
100	3	0.5 (1.1)	75/63	16.1	13.6	20.5	1.50	10.7	Extended Range - Anti-freeze required	AHR/ISO 13256-1 certified performance is rated at entering air conditions of 80.6°F DB and 66.2°F WB in cooling and 68°F DB in heating.	Tabulated unit performance does not include fan or pump power corrections required for AHR/ISO standard performance ratings.	Unit performance may be interpolated. Extrapolation is not allowed.	For conditions other than rating conditions provided, consult the BST selection software.	Ratings below 40°F are with a methanol solution.	The results reported herein are estimates based on testing by FHP. Variations in the installation and operational environment may alter performance. Bosch disclaims all warranties, express and implied, that the performance will be as reported, including the warranty of merchantability and fitness for purpose. In addition, continuous research and development may result in a change to an appliances design and specifications, which Bosch may change without notice. Before purchase, confirm the design specifications of the appliance.							
			80/67	17.2	14.1	21.8	1.51	11.4														
			85/71	18.4	14.6	23.0	1.52	12.2														
	4	0.8 (1.9)	75/63	16.4	13.7	20.7	1.46	11.3								60	0.5 (1.2)	60	25.7	22.8	1.18	6.4
			80/67	17.5	14.2	22.0	1.46	12.0										70	25.0	21.0	1.33	5.5
			85/71	18.8	14.7	23.3	1.47	12.8										80	24.1	19.8	1.48	4.8
	6	1.7 (3.9)	75/63	16.6	13.8	20.9	1.42	11.7								60	0.9 (2.1)	60	26.8	23.4	1.19	6.6
			80/67	17.9	14.3	22.1	1.42	12.6										70	25.6	21.8	1.34	5.6
			85/71	19.2	14.8	23.5	1.42	13.5										80	24.7	20.0	1.49	4.9
110	3	0.5 (1.1)	75/63	14.9	13.1	19.9	1.69	8.8	110	1.6 (3.8)	60	27.5	24.3	1.21	6.6							
			80/67	16.0	13.6	21.1	1.69	9.5				70	26.5	22.4	1.36	5.7						
			85/71	17.1	14.1	22.3	1.70	10.1				80	25.2	20.3	1.50	4.9						
	4	0.8 (1.8)	75/63	15.2	13.2	20.0	1.65	9.2			60	1.6 (3.8)	60	27.5	24.3	1.21	6.6					
			80/67	16.3	13.7	21.2	1.65	9.9					70	26.5	22.4	1.36	5.7					
			85/71	17.5	14.2	22.4	1.65	10.6					80	25.2	20.3	1.50	4.9					
	6	1.6 (3.8)	75/63	15.4	13.3	20.2	1.61	9.6			60	1.6 (3.8)	60	27.5	24.3	1.21	6.6					
			80/67	16.6	13.8	21.4	1.61	10.3					70	26.5	22.4	1.36	5.7					
			85/71	17.8	14.3	22.6	1.61	11.1					80	25.2	20.3	1.50	4.9					



Capacity Data

ES025 – Full Load (900 CFM)

Cooling									Heating							
Entering Fluid Temp (°F)	Water Flow (GPM)	Pressure Drop PSI (FOH)	Entering Air Temp (db/wb) °F	Total Capacity (MBTUH)	Sensible Capacity (MBTUH)	Heat of Rejection (MBTUH)	Power Input (kW)	EER	Entering Fluid Temp (°F)	Pressure Drop PSI (FOH)	Entering Air Temp (°F)	Total Capacity (MBTUH)	Heat of Absorption (MBTUH)	Power Input (kW)	COP	
50	3	0.6 (1.3)	75/63	28.1	21.9	32.9	1.49	18.9	30	0.7 (1.5)	60	19.8	14.7	1.58	3.7	
			80/67	29.9	22.6	34.8	1.51	19.8				70	19.5	13.7	1.75	3.3
			85/71	31.8	23.2	36.8	1.54	20.7				80	19.3	12.8	1.95	2.9
	4	1.0 (2.2)	75/63	28.6	22.2	33.3	1.44	19.9		1.1 (2.5)	60	20.5	15.3	1.60	3.8	
			80/67	30.6	22.9	35.3	1.46	21.1				70	20.1	14.3	1.77	3.3
			85/71	32.5	23.5	37.4	1.47	22.1				80	19.8	13.3	1.96	3.0
	6	2.0 (4.6)	75/63	29.2	22.4	33.7	1.39	21.0		2.2 (5.1)	60	21.3	16.0	1.61	3.9	
			80/67	31.2	23.1	35.8	1.40	22.3				70	20.8	14.9	1.78	3.4
			85/71	33.3	23.8	37.9	1.41	23.7				80	20.4	13.9	1.97	3.0
60	3	0.6 (1.3)	75/63	26.8	21.4	31.9	1.63	16.5	40	0.6 (1.4)	60	22.4	17.2	1.64	4.0	
			80/67	28.5	22.1	33.8	1.65	17.3				70	22.0	16.1	1.81	3.6
			85/71	30.4	22.7	35.8	1.68	18.1				80	21.7	15.2	2.00	3.2
	4	0.9 (2.1)	75/63	27.4	21.6	32.4	1.57	17.5		1.0 (2.4)	60	23.4	18.0	1.66	4.1	
			80/67	29.2	22.3	34.3	1.59	18.4				70	23.0	16.9	1.82	3.7
			85/71	31.1	22.9	36.3	1.61	19.4				80	22.4	15.8	2.02	3.2
	6	1.9 (4.4)	75/63	27.9	21.8	32.7	1.51	18.5		2.1 (4.9)	60	24.3	18.9	1.68	4.2	
			80/67	29.8	22.6	34.7	1.53	19.6				70	23.8	17.7	1.84	3.8
			85/71	31.8	23.2	36.8	1.54	20.7				80	23.2	16.6	2.04	3.3
70	3	0.5 (1.2)	75/63	25.5	20.9	31.1	1.78	14.3	50	0.6 (1.4)	60	25.4	19.8	1.70	4.4	
			80/67	27.2	21.5	32.9	1.81	15.0				70	25.1	18.8	1.87	3.9
			85/71	28.9	22.2	34.8	1.85	15.7				80	24.6	17.7	2.06	3.5
	4	0.9 (2.1)	75/63	26.0	21.1	31.4	1.72	15.2		1.0 (2.3)	60	26.4	20.8	1.72	4.5	
			80/67	27.7	21.8	33.3	1.74	15.9				70	25.9	19.7	1.89	4.0
			85/71	29.5	22.4	35.2	1.77	16.7				80	25.5	18.5	2.09	3.6
	6	1.9 (4.3)	75/63	26.5	21.3	31.8	1.66	16.0		2.0 (4.7)	60	27.6	22.0	1.74	4.6	
			80/67	28.3	22.0	33.7	1.68	16.9				70	27.0	20.7	1.92	4.1
			85/71	30.2	22.7	35.7	1.70	17.8				80	26.5	19.4	2.11	3.7
80	3	0.5 (1.2)	75/63	24.2	20.3	30.3	1.96	12.4	60	0.6 (1.3)	60	28.5	22.6	1.76	4.7	
			80/67	25.8	21.0	32.1	2.00	12.9				70	28.0	21.5	1.94	4.2
			85/71	27.4	21.7	33.8	2.04	13.5				80	27.5	20.4	2.14	3.8
	4	0.9 (2)	75/63	24.7	20.5	30.6	1.89	13.1		1.0 (2.2)	60	29.8	23.8	1.79	4.9	
			80/67	26.3	21.2	32.4	1.92	13.7				70	29.1	22.7	1.97	4.3
			85/71	28.0	21.9	34.2	1.95	14.4				80	28.6	21.3	2.17	3.9
	6	1.8 (4.1)	75/63	25.1	20.7	30.9	1.83	13.7		2.0 (4.6)	60	31.2	25.2	1.82	5.0	
			80/67	26.9	21.4	32.7	1.85	14.6				70	30.4	23.9	2.00	4.4
			85/71	28.6	22.1	34.6	1.88	15.3				80	29.8	22.4	2.21	4.0
85	3	0.5 (1.2)	75/63	23.5	20.0	29.9	2.06	11.4	70	0.6 (1.3)	60	32.3	25.9	1.84	5.1	
			80/67	25.1	20.7	31.6	2.10	12.0				70	29.2	22.5	1.97	4.3
			85/71	26.7	21.4	33.4	2.13	12.6				80	30.5	23.1	2.23	4.0
	4	0.9 (2)	75/63	24.0	20.2	30.2	1.99	12.1		0.9 (2.1)	60	33.3	27.2	1.86	5.2	
			80/67	25.6	20.9	32.0	2.02	12.7				70	32.1	25.7	2.05	4.6
			85/71	27.3	21.6	33.8	2.05	13.3				80	31.8	24.3	2.27	4.1
	6	1.8 (4.1)	75/63	24.4	20.4	30.4	1.93	12.7		1.9 (4.4)	60	35.0	28.7	1.90	5.4	
			80/67	26.1	21.1	32.3	1.95	13.4				70	34.0	27.5	2.09	4.8
			85/71	27.9	21.8	34.1	1.98	14.2				80	33.3	25.6	2.30	4.2
90	3	0.5 (1.2)	75/63	22.8	19.2	29.5	2.16	10.6	80	0.5 (1.2)	60	35.7	29.7	1.92	5.5	
			80/67	24.4	20.5	31.2	2.20	11.1				70	34.6	27.6	2.10	4.8
			85/71	26.0	21.1	33.0	2.24	11.7				80	33.8	26.1	2.32	4.3
	4	0.8 (1.9)	75/63	23.3	19.9	29.8	2.09	11.2		0.9 (2.1)	60	37.3	30.7	1.95	5.6	
			80/67	24.9	20.7	31.5	2.13	11.7				70	36.4	28.9	2.14	5.0
			85/71	26.6	21.3	33.4	2.16	12.4				80	35.3	27.4	2.36	4.4
	6	1.7 (4)	75/63	23.7	20.1	30.0	2.03	11.7		1.9 (4.3)	60	38.6	31.9	1.98	5.7	
			80/67	25.4	20.9	31.8	2.05	12.4				70	37.8	30.9	2.19	5.1
			85/71	27.1	21.6	33.6	2.08	13.1				80	37.1	29.0	2.42	4.5
100	3	0.5 (1.1)	75/63	21.5	18.7	28.8	2.38	9.0	Extended Range - Anti-freeze required	AHR/ISO13256-1 certified performance is rated at entering air conditions of 80.6°F DB and 66.2°F WB in cooling and 68°F DB in heating.	Tabulated unit performance does not include fan or pump power corrections required for AHR/ISO standard performance ratings.	Unit performance may be interpolated. Extrapolation is not allowed.	For conditions other than rating conditions provided, consult the BST selection software.	Ratings below 40°F are with a methanol solution.	The results reported herein are estimates based on testing by FHP. Variations in the installation and operational environment may alter performance. Bosch disclaims all warranties, express and implied, that the performance will be as reported, including the warranty of merchantability and fitness for purpose. In addition, continuous research and development may result in a change to an appliances design and specifications, which Bosch may change without notice. Before purchase, confirm the design specifications of the appliance.	
			80/67	23.0	19.4	30.5	2.42	9.5								
			85/71	24.5	20.7	32.2	2.46	10.0								
	4	0.8 (1.9)	75/63	21.9	18.9	29.0	2.32	9.5								
			80/67	23.4	20.1	30.7	2.34	10.0								
			85/71	25.1	20.8	32.5	2.38	10.6								
	6	1.7 (3.9)	75/63	22.3	19.0	29.2	2.25	9.9								
			80/67	23.9	20.3	31.0	2.27	10.5								
			85/71	25.5	21.0	32.7	2.30	11.1								
110	3	0.5 (1.1)	75/63	20.1	18.1	28.2	2.63	7.7								
			80/67	21.5	18.7	29.8	2.66	8.1								
			85/71	23.0	19.6	31.4	2.70	8.5								
	4	0.8 (1.8)	75/63	20.5	18.2	28.3	2.56	8.0								
			80/67	22.0	18.9	30.0	2.59	8.5								
			85/71	23.5	19.7	31.7	2.62	9.0								
	6	1.6 (3.8)	75/63	20.8	18.3	28.5	2.50	8.3								
			80/67	22.3	19.2	30.2	2.52	8.9								
			85/71	24.0	20.4	31.9	2.55	9.4								

Extended Range - Anti-freeze required

AHR/ISO13256-1 certified performance is rated at entering air conditions of 80.6°F DB and 66.2°F WB in cooling and 68°F DB in heating.

Tabulated unit performance does not include fan or pump power corrections required for AHR/ISO standard performance ratings.

Unit performance may be interpolated. Extrapolation is not allowed.

For conditions other than rating conditions provided, consult the BST selection software.

Ratings below 40°F are with a methanol solution.

The results reported herein are estimates based on testing by FHP. Variations in the installation and operational environment may alter performance. Bosch disclaims all warranties, express and implied, that the performance will be as reported, including the warranty of merchantability and fitness for purpose. In addition, continuous research and development may result in a change to an appliances design and specifications, which Bosch may change without notice. Before purchase, confirm the design specifications of the appliance.



Capacity Data

ES035 – Part Load (1050 CFM)

Cooling									Heating											
Entering Fluid Temp (°F)	Water Flow (GPM)	Pressure Drop PSI (FOH)	Entering Air Temp (db/wb) °F	Total Capacity (MBTUH)	Sensible Capacity (MBTUH)	Heat of Rejection (MBTUH)	Power Input (kW)	EER	Entering Fluid Temp (°F)	Pressure Drop PSI (FOH)	Entering Air Temp (°F)	Total Capacity (MBTUH)	Heat of Absorption (MBTUH)	Power Input (kW)	COP					
50	4.5	1.2 (2.7)	75/63	28.3	23.7	32.3	1.22	23.1	30	1.3 (3)	60	18.3	13.7	1.44	3.7					
			80/67	30.5	24.6	34.5	1.25	24.4			70	17.9	12.7	1.62	3.2					
			85/71	32.6	25.4	36.8	1.28	25.4			80	17.6	11.7	1.83	2.8					
	6	2.0 (4.5)	75/63	28.8	23.9	32.6	1.18	24.4		60	18.8	14.2	1.44	3.8						
			80/67	30.9	24.8	34.9	1.20	25.7		70	18.4	13.1	1.63	3.3						
			85/71	33.1	25.6	37.2	1.23	26.9		80	18.0	12.0	1.84	2.9						
	9	4.1 (9.4)	75/63	29.2	24.1	32.9	1.13	25.8		60	19.4	14.7	1.45	3.9						
			80/67	31.4	25.0	35.2	1.15	27.2		70	18.9	13.6	1.64	3.4						
			85/71	33.7	25.8	37.6	1.18	28.6		80	18.4	12.5	1.85	2.9						
60	4.5	1.1 (2.6)	75/63	26.9	23.1	31.3	1.38	19.5	40	1.3 (2.9)	60	21.7	16.9	1.49	4.3					
			80/67	29.0	24.0	33.5	1.40	20.7			70	21.2	15.8	1.68	3.7					
			85/71	31.0	24.9	35.7	1.43	21.7			80	20.8	14.7	1.89	3.2					
	6	1.9 (4.4)	75/63	27.3	23.3	31.6	1.33	20.5		60	22.4	17.5	1.50	4.4						
			80/67	29.4	24.2	33.8	1.35	21.7		70	21.9	16.3	1.69	3.8						
			85/71	31.5	25.1	36.0	1.38	22.9		80	21.4	15.2	1.90	3.3						
	9	3.9 (9.1)	75/63	27.8	23.5	31.9	1.29	21.6		60	23.1	18.2	1.51	4.5						
			80/67	29.9	24.4	34.1	1.31	22.9		70	22.5	17.0	1.70	3.9						
			85/71	32.1	25.3	36.4	1.33	24.1		80	22.0	15.7	1.92	3.4						
70	4.5	1.1 (2.5)	75/63	25.5	22.5	30.4	1.54	16.6	50	1.2 (2.8)	60	25.4	20.3	1.55	4.8					
			80/67	27.4	23.5	32.4	1.56	17.5			70	24.8	19.1	1.75	4.2					
			85/71	29.4	24.4	34.5	1.59	18.5			80	24.4	17.8	1.97	3.6					
	6	1.8 (4.2)	75/63	25.9	22.7	30.6	1.49	17.3		60	26.2	21.1	1.57	4.9						
			80/67	27.9	23.7	32.7	1.52	18.4		70	25.6	19.8	1.76	4.3						
			85/71	29.9	24.6	34.9	1.54	19.4		80	25.1	18.5	1.98	3.7						
	9	3.8 (8.8)	75/63	26.3	22.9	30.9	1.45	18.1		60	27.2	22.0	1.58	5.0						
			80/67	28.3	23.8	33.0	1.47	19.3		70	26.5	20.6	1.78	4.4						
			85/71	30.4	24.7	35.2	1.49	20.4		80	25.9	19.3	2.00	3.8						
80	4.5	1.0 (2.4)	75/63	24.0	21.9	29.4	1.72	13.9	60	1.2 (2.7)	60	29.3	24.0	1.63	5.3					
			80/67	25.9	22.9	31.4	1.74	14.8			70	28.6	22.6	1.83	4.6					
			85/71	27.8	23.8	33.4	1.77	15.7			80	28.1	21.3	2.06	4.0					
	6	1.8 (4.1)	75/63	24.4	22.1	29.6	1.67	14.6		60	30.3	25.0	1.65	5.4						
			80/67	26.3	23.1	31.6	1.69	15.5		70	29.6	23.5	1.85	4.7						
			85/71	28.2	24.0	33.7	1.71	16.4		80	29.0	22.1	2.08	4.1						
	9	3.7 (8.5)	75/63	24.7	22.3	29.8	1.63	15.2		60	31.5	26.0	1.67	5.5						
			80/67	26.7	23.2	31.9	1.64	16.2		70	30.7	24.5	1.87	4.8						
			85/71	28.8	24.1	34.1	1.66	17.3		80	29.9	23.0	2.10	4.2						
85	4.5	1.0 (2.4)	75/63	23.3	21.7	28.9	1.82	12.8	70	1.1 (2.6)	60	33.5	27.9	1.71	5.7					
			80/67	25.1	22.6	30.9	1.84	13.6			70	32.6	26.3	1.92	5.0					
			85/71	27.0	23.5	32.9	1.87	14.4			80	32.0	24.8	2.15	4.4					
	6	1.7 (4)	75/63	23.6	21.8	29.1	1.77	13.3		60	34.7	29.0	1.73	5.9						
			80/67	25.5	22.7	31.1	1.79	14.2		70	33.8	27.4	1.95	5.1						
			85/71	27.4	23.7	33.2	1.81	15.1		80	33.0	25.8	2.18	4.4						
	9	3.6 (8.4)	75/63	24.0	21.9	29.4	1.73	13.9		60	36.1	30.4	1.75	6.0						
			80/67	25.9	22.9	31.4	1.74	14.9		70	35.2	28.6	1.97	5.2						
			85/71	27.9	23.8	33.5	1.76	15.9		80	34.2	26.9	2.21	4.5						
90	4.5	1.0 (2.4)	75/63	22.5	21.4	28.5	1.93	11.7	80	1.1 (2.5)	60	37.7	31.9	1.78	6.2					
			80/67	24.3	22.4	30.4	1.95	12.5			70	36.9	30.2	1.99	5.4					
			85/71	26.2	23.3	32.4	1.97	13.3			80	36.1	28.5	2.24	4.7					
	6	1.7 (4)	75/63	22.8	21.5	28.7	1.88	12.1		60	39.3	33.4	1.81	6.4						
			80/67	24.7	22.5	30.6	1.90	13.0		70	38.3	31.6	2.02	5.6						
			85/71	26.6	23.4	32.6	1.91	13.9		80	37.4	29.8	2.26	4.8						
	9	3.6 (8.2)	75/63	23.2	21.6	28.9	1.83	12.7		60	40.9	35.2	1.84	6.5						
			80/67	25.1	22.6	30.9	1.85	13.6		70	39.8	33.1	2.05	5.7						
			85/71	27.0	23.5	32.9	1.86	14.5		80	38.8	31.1	2.29	5.0						
100	4.5	1.0 (2.3)	75/63	21.1	20.1	27.7	2.17	9.7	Extended Range - Anti-freeze required	AHRI/ISO 13256-1 certified performance is rated at entering air conditions of 80.6°F DB and 66.2°F WB in cooling and 68°F DB in heating. Tabulated unit performance does not include fan or pump power corrections required for AHRI/ISO standard performance ratings. Unit performance may be interpolated. Extrapolation is not allowed. For conditions other than rating conditions provided, consult the BST selection software. Ratings below 40°F are with a methanol solution. The results reported herein are estimates based on testing by FHP. Variations in the installation and operational environment may alter performance. Bosch disclaims all warranties, express and implied, that the performance will be as reported, including the warranty of merchantability and fitness for purpose. In addition, continuous research and development may result in a change to an appliances design and specifications, which Bosch may change without notice. Before purchase, confirm the design specifications of the appliance.	1.6 (3.8)	75/63	21.4	20.3	27.9	2.11	10.1			
			80/67	23.1	21.9	29.7	2.13	10.9												
			85/71	24.9	22.9	31.6	2.14	11.6												
	6	3.5 (8)	75/63	21.7	20.4	28.0	2.06	10.5												
			80/67	23.5	22.0	29.9	2.07	11.3												
			85/71	25.3	23.0	31.9	2.08	12.2												
	110	4.5	1.0 (2.2)	75/63	19.6	19.4	27.1	2.44			8.0	Extended Range - Anti-freeze required	AHRI/ISO 13256-1 certified performance is rated at entering air conditions of 80.6°F DB and 66.2°F WB in cooling and 68°F DB in heating. Tabulated unit performance does not include fan or pump power corrections required for AHRI/ISO standard performance ratings. Unit performance may be interpolated. Extrapolation is not allowed. For conditions other than rating conditions provided, consult the BST selection software. Ratings below 40°F are with a methanol solution. The results reported herein are estimates based on testing by FHP. Variations in the installation and operational environment may alter performance. Bosch disclaims all warranties, express and implied, that the performance will be as reported, including the warranty of merchantability and fitness for purpose. In addition, continuous research and development may result in a change to an appliances design and specifications, which Bosch may change without notice. Before purchase, confirm the design specifications of the appliance.	1.6 (3.7)	75/63	19.9	19.6	27.2	2.38	8.4
				80/67	21.6	20.6	29.0	2.39			9.0									
				85/71	23.3	22.3	30.8	2.40			9.7									
6		3.4 (7.8)	75/63	20.2	19.7	27.3	2.33	8.7												
			80/67	21.9	20.7	29.1	2.33	9.4												
			85/71	23.6	22.4	30.9	2.34	10.1												



Capacity Data

ES035 – Full Load (1225 CFM)

Cooling									Heating							
Entering Fluid Temp (°F)	Water Flow (GPM)	Pressure Drop PSI (FOH)	Entering Air Temp (db/wb) °F	Total Capacity (MBTUH)	Sensible Capacity (MBTUH)	Heat of Rejection (MBTUH)	Power Input (kW)	EER	Entering Fluid Temp (°F)	Pressure Drop PSI (FOH)	Entering Air Temp (°F)	Total Capacity (MBTUH)	Heat of Absorption (MBTUH)	Power Input (kW)	COP	
50	4.5	1.2 (2.7)	75/63	39.2	30.1	45.9	2.08	18.9	30	1.3 (3)	60	26.7	19.6	2.24	3.5	
			80/67	41.9	31.0	48.8	2.10	19.9			70	26.3	18.4	2.45	3.1	
			85/71	44.8	31.9	51.8	2.14	21.0			80	25.7	17.1	2.68	2.8	
	6	2.0 (4.5)	75/63	39.9	30.4	46.4	2.00	20.0		60	27.6	20.3	2.25	3.6		
			80/67	42.8	31.3	49.4	2.02	21.2		70	27.0	19.1	2.47	3.2		
			85/71	45.7	32.3	52.4	2.04	22.3		80	26.4	17.8	2.70	2.9		
	9	4.1 (9.4)	75/63	40.7	30.7	46.9	1.92	21.2		60	28.5	21.2	2.27	3.7		
			80/67	43.6	31.7	50.0	1.93	22.5		70	27.9	19.8	2.48	3.3		
			85/71	46.6	32.7	53.1	1.95	23.9		80	27.3	18.5	2.71	3.0		
60	4.5	1.1 (2.6)	75/63	37.4	29.3	44.7	2.27	16.5	40	1.3 (2.9)	60	30.7	23.2	2.31	3.9	
			80/67	40.1	30.3	47.5	2.30	17.4			70	30.2	21.9	2.53	3.5	
			85/71	42.8	31.1	50.4	2.33	18.4			80	29.7	20.6	2.77	3.1	
	6	1.9 (4.4)	75/63	38.1	29.6	45.2	2.19	17.4		60	31.8	24.2	2.33	4.0		
			80/67	40.9	30.6	48.1	2.21	18.5		70	31.1	22.8	2.55	3.6		
			85/71	43.7	31.5	51.0	2.24	19.5		80	30.6	21.4	2.79	3.2		
	9	3.9 (9.1)	75/63	38.9	29.9	45.7	2.11	18.4		60	32.9	25.3	2.35	4.1		
			80/67	41.7	30.9	48.6	2.13	19.6		70	32.2	23.8	2.58	3.7		
			85/71	44.6	31.8	51.7	2.15	20.7		80	31.5	22.3	2.82	3.3		
70	4.5	1.1 (2.5)	75/63	35.6	27.8	43.5	2.48	14.4	50	1.2 (2.8)	60	35.0	27.1	2.40	4.3	
			80/67	38.1	29.6	46.2	2.50	15.2			70	34.3	25.7	2.63	3.8	
			85/71	40.7	30.5	48.9	2.53	16.1			80	33.6	24.3	2.87	3.4	
	6	1.8 (4.2)	75/63	36.3	28.1	44.0	2.40	15.1		60	36.3	28.4	2.42	4.4		
			80/67	38.9	29.9	46.7	2.42	16.1		70	35.5	26.8	2.65	3.9		
			85/71	41.6	30.8	49.5	2.44	17.0		80	34.7	25.3	2.90	3.5		
	9	3.8 (8.8)	75/63	37.0	28.4	44.4	2.32	15.9		60	37.7	29.7	2.45	4.5		
			80/67	39.6	30.2	47.2	2.34	16.9		70	36.9	28.1	2.69	4.0		
			85/71	42.5	31.2	50.1	2.35	18.1		80	36.0	26.4	2.94	3.6		
80	4.5	1.0 (2.4)	75/63	33.6	27.1	42.2	2.70	12.4	60	1.2 (2.7)	60	39.6	31.4	2.48	4.7	
			80/67	36.2	28.7	44.9	2.73	13.2			70	38.8	29.8	2.72	4.2	
			85/71	38.7	29.7	47.5	2.76	14.0			80	38.1	28.2	2.99	3.7	
	6	1.8 (4.1)	75/63	34.3	27.4	42.6	2.62	13.1		60	41.1	33.0	2.51	4.8		
			80/67	36.8	29.1	45.3	2.64	13.9		70	40.3	31.3	2.75	4.3		
			85/71	39.4	30.1	48.0	2.66	14.8		80	39.5	29.5	3.02	3.8		
	9	3.7 (8.5)	75/63	35.0	27.5	43.1	2.55	13.7		60	42.9	34.7	2.55	4.9		
			80/67	37.6	29.3	45.9	2.56	14.7		70	42.0	32.8	2.78	4.4		
			85/71	40.3	30.4	48.6	2.57	15.6		80	41.0	30.9	3.05	3.9		
85	4.5	1.0 (2.4)	75/63	32.7	26.7	41.7	2.82	11.6	70	1.1 (2.6)	60	44.4	36.0	2.57	5.1	
			80/67	35.1	28.4	44.2	2.85	12.3			70	43.4	34.4	2.81	4.5	
			85/71	37.5	29.4	46.8	2.88	13.0			80	42.7	32.5	3.08	4.1	
	6	1.7 (4)	75/63	33.3	27.0	42.0	2.74	12.1		60	46.3	37.8	2.61	5.2		
			80/67	35.8	28.1	44.6	2.76	13.0		70	45.3	36.0	2.85	4.7		
			85/71	38.4	29.7	47.3	2.78	13.8		80	44.4	34.1	3.12	4.2		
	9	3.6 (8.4)	75/63	34.0	27.1	42.5	2.67	12.7		60	48.5	39.8	2.66	5.4		
			80/67	36.5	29.0	45.1	2.68	13.6		70	47.3	37.9	2.89	4.8		
			85/71	39.2	29.9	47.9	2.70	14.5		80	46.2	35.8	3.16	4.3		
90	4.5	1.0 (2.4)	75/63	31.8	26.2	41.1	2.95	10.8	80	1.1 (2.5)	60	49.5	40.8	2.68	5.4	
			80/67	34.1	27.2	43.6	2.98	11.4			70	48.5	38.9	2.92	4.9	
			85/71	36.5	29.0	46.1	3.01	12.1			80	47.6	37.0	3.19	4.4	
	6	1.7 (4)	75/63	32.4	26.6	41.4	2.87	11.3		60	51.7	42.8	2.73	5.6		
			80/67	34.8	28.2	44.0	2.89	12.0		70	50.6	40.8	2.97	5.0		
			85/71	37.3	29.3	46.7	2.91	12.8		80	49.5	38.8	3.24	4.5		
	9	3.6 (8.2)	75/63	32.9	26.8	41.8	2.79	11.8		60	54.3	45.2	2.78	5.7		
			80/67	35.5	27.7	44.5	2.81	12.6		70	52.9	43.0	3.03	5.1		
			85/71	38.1	29.5	47.2	2.82	13.5		80	51.6	40.8	3.30	4.6		
100	4.5	1.0 (2.3)	75/63	29.9	25.3	40.1	3.22	9.3	Extended Range - Anti-freeze required	AHR/ISO13256-1 certified performance is rated at entering air conditions of 80.6°F DB and 66.2°F WB in cooling and 68°F DB in heating. Tabulated unit performance does not include fan or pump power corrections required for AHR/ISO standard performance ratings. Unit performance may be interpolated. Extrapolation is not allowed. For conditions other than rating conditions provided, consult the BST selection software. Ratings below 40°F are with a methanol solution. The results reported herein are estimates based on testing by FHP. Variations in the installation and operational environment may alter performance. Bosch disclaims all warranties, express and implied, that the performance will be as reported, including the warranty of merchantability and fitness for purpose. In addition, continuous research and development may result in a change to an appliances design and specifications, which Bosch may change without notice. Before purchase, confirm the design specifications of the appliance.	1.1 (2.5)	60	51.6	40.8	3.30	4.6
			80/67	32.1	26.5	42.4	3.25	9.9				70	50.6	40.8	2.97	5.0
			85/71	34.4	27.4	44.9	3.29	10.5				80	49.5	38.8	3.24	4.5
	6	1.6 (3.8)	75/63	30.5	25.6	40.4	3.14	9.7			60	54.3	45.2	2.78	5.7	
			80/67	32.7	26.8	42.7	3.16	10.3			70	53.3	43.8	3.03	5.1	
			85/71	35.1	27.8	45.2	3.19	11.0			80	52.3	42.4	3.28	4.6	
	9	3.5 (8)	75/63	31.0	25.7	40.7	3.07	10.1			60	57.3	48.2	2.82	6.0	
			80/67	33.3	27.0	43.1	3.08	10.8			70	56.3	46.8	3.07	5.5	
			85/71	35.8	28.8	45.7	3.10	11.6			80	55.3	45.4	3.32	5.0	
110	4.5	1.0 (2.2)	75/63	28.0	24.5	39.1	3.52	7.9	AHR/ISO13256-1 certified performance is rated at entering air conditions of 80.6°F DB and 66.2°F WB in cooling and 68°F DB in heating. Tabulated unit performance does not include fan or pump power corrections required for AHR/ISO standard performance ratings. Unit performance may be interpolated. Extrapolation is not allowed. For conditions other than rating conditions provided, consult the BST selection software. Ratings below 40°F are with a methanol solution. The results reported herein are estimates based on testing by FHP. Variations in the installation and operational environment may alter performance. Bosch disclaims all warranties, express and implied, that the performance will be as reported, including the warranty of merchantability and fitness for purpose. In addition, continuous research and development may result in a change to an appliances design and specifications, which Bosch may change without notice. Before purchase, confirm the design specifications of the appliance.	1.1 (2.5)	60	51.6	40.8	3.30	4.6	
			80/67	30.0	25.7	41.3	3.56	8.4			70	50.6	40.8	2.97	5.0	
			85/71	32.3	26.5	43.7	3.60	9.0			80	49.5	38.8	3.24	4.5	
	6	1.6 (3.7)	75/63	28.5	24.7	39.4	3.44	8.3		60	54.3	45.2	2.78	5.7		
			80/67	30.7	25.8	41.7	3.47	8.8		70	53.3	43.8	3.03	5.1		
			85/71	32.9	26.8	44.1	3.49	9.4		80	52.3	42.4	3.28	4.6		
	9	3.4 (7.8)	75/63	29.0	24.9	39.6	3.37	8.6		60	57.3	48.2	2.82	6.0		
			80/67	31.2	26.1	41.9	3.38	9.2		70	56.3	46.8	3.07	5.5		
			85/71	33.5	27.0	44.4	3.41	9.8		80	55.3	45.4	3.32	5.0		

Extended Range - Anti-freeze required
 AHR/ISO13256-1 certified performance is rated at entering air conditions of 80.6°F DB and 66.2°F WB in cooling and 68°F DB in heating.
 Tabulated unit performance does not include fan or pump power corrections required for AHR/ISO standard performance ratings.
 Unit performance may be interpolated. Extrapolation is not allowed.
 For conditions other than rating conditions provided, consult the BST selection software.
 Ratings below 40°F are with a methanol solution.
 The results reported herein are estimates based on testing by FHP. Variations in the installation and operational environment may alter performance. Bosch disclaims all warranties, express and implied, that the performance will be as reported, including the warranty of merchantability and fitness for purpose. In addition, continuous research and development may result in a change to an appliances design and specifications, which Bosch may change without notice. Before purchase, confirm the design specifications of the appliance.



Capacity Data

ES049 – Part Load (1100 CFM)

Cooling									Heating							
Entering Fluid Temp (°F)	Water Flow (GPM)	Pressure Drop PSI (FOH)	Entering Air Temp (db/wb) °F	Total Capacity (MBTUH)	Sensible Capacity (MBTUH)	Heat of Rejection (MBTUH)	Power Input (kW)	EER	Entering Fluid Temp (°F)	Pressure Drop PSI (FOH)	Entering Air Temp (°F)	Total Capacity (MBTUH)	Heat of Absorption (MBTUH)	Power Input (kW)	COP	
50	6	1.3 (3.1)	75/63	36.5	27.7	41.7	1.62	22.6	30	1.5 (3.5)	60	26.4	19.6	2.06	3.8	
			80/67	38.8	28.6	43.9	1.60	24.3			70	25.7	18.1	2.29	3.3	
			85/71	41.3	29.2	46.4	1.58	26.2			80	25.1	16.5	2.55	2.9	
	8	2.3 (5.2)	75/63	37.1	28.0	42.1	1.55	23.9		60	27.1	20.2	2.07	3.8		
			80/67	39.5	28.8	44.4	1.53	25.8		70	26.1	18.7	2.30	3.3		
			85/71	42.1	29.5	47.0	1.50	28.1		80	25.7	17.0	2.56	2.9		
	12	4.7 (10.9)	75/63	37.8	28.4	42.6	1.49	25.4		60	27.7	21.0	2.08	3.9		
			80/67	40.2	29.2	45.0	1.46	27.5		70	26.8	19.3	2.31	3.4		
			85/71	42.9	29.9	47.6	1.43	30.1		80	26.1	17.5	2.57	3.0		
60	6	1.3 (3)	75/63	34.7	27.0	40.4	1.80	19.3	40	1.5 (3.4)	60	29.8	22.8	2.10	4.2	
			80/67	37.0	27.8	42.7	1.78	20.7			70	29.0	21.3	2.34	3.6	
			85/71	39.3	28.6	45.0	1.76	22.3			80	28.4	19.7	2.61	3.2	
	8	2.2 (5.1)	75/63	35.3	27.3	40.9	1.73	20.3		60	30.6	23.6	2.11	4.2		
			80/67	37.6	28.1	43.1	1.71	21.9		70	29.8	22.0	2.35	3.7		
			85/71	40.0	28.9	45.5	1.69	23.7		80	29.1	20.4	2.62	3.3		
	12	4.6 (10.5)	75/63	36.0	27.6	41.3	1.67	21.6		60	31.5	24.5	2.12	4.4		
			80/67	38.3	28.4	43.6	1.64	23.3		70	30.5	22.9	2.36	3.8		
			85/71	40.9	29.1	46.1	1.61	25.4		80	29.7	21.1	2.63	3.3		
70	6	1.3 (2.9)	75/63	32.9	26.3	39.3	2.01	16.4	50	1.4 (3.2)	60	33.5	26.4	2.14	4.6	
			80/67	35.1	27.1	41.4	1.99	17.6			70	32.7	24.8	2.39	4.0	
			85/71	37.4	27.9	43.7	1.97	19.0			80	32.1	23.0	2.67	3.5	
	8	2.1 (4.9)	75/63	33.5	26.5	39.6	1.94	17.3		60	34.5	27.4	2.15	4.7		
			80/67	35.7	27.4	41.8	1.92	18.6		70	33.6	25.6	2.40	4.1		
			85/71	38.1	28.1	44.2	1.89	20.1		80	32.9	23.9	2.68	3.6		
	12	4.4 (10.2)	75/63	34.1	26.8	40.0	1.87	18.2		60	35.6	28.5	2.16	4.8		
			80/67	36.4	27.6	42.3	1.84	19.7		70	34.6	26.7	2.41	4.2		
			85/71	38.9	28.4	44.7	1.81	21.5		80	33.8	24.8	2.70	3.7		
80	6	1.2 (2.8)	75/63	31.1	24.9	38.1	2.25	13.8	60	1.3 (3.1)	60	37.5	30.3	2.17	5.1	
			80/67	33.2	26.4	40.2	2.23	14.9			70	36.7	28.6	2.42	4.4	
			85/71	35.4	27.1	42.4	2.21	16.0			80	36.0	26.8	2.71	3.9	
	8	2.0 (4.7)	75/63	31.6	25.2	38.4	2.17	14.5		60	38.7	31.5	2.17	5.2		
			80/67	33.8	26.6	40.6	2.15	15.7		70	37.8	29.7	2.42	4.6		
			85/71	36.0	27.5	42.8	2.13	16.9		80	37.0	27.8	2.71	4.0		
	12	4.3 (9.8)	75/63	32.2	26.0	38.8	2.10	15.3		60	40.1	32.9	2.18	5.4		
			80/67	34.4	26.9	41.0	2.07	16.6		70	39.0	30.9	2.43	4.7		
			85/71	36.7	27.7	43.2	2.04	18.0		80	37.9	29.0	2.71	4.1		
85	6	1.2 (2.8)	75/63	30.2	24.4	37.6	2.38	12.7	70	1.3 (3)	60	41.7	34.5	2.18	5.6	
			80/67	32.2	26.0	39.7	2.36	13.6			70	40.8	32.7	2.43	4.9	
			85/71	34.3	26.9	41.7	2.34	14.6			80	40.0	30.7	2.72	4.3	
	8	2.0 (4.7)	75/63	30.7	24.8	37.9	2.30	13.3		60	43.1	35.9	2.18	5.8		
			80/67	32.8	26.2	40.0	2.28	14.4		70	42.1	34.0	2.43	5.1		
			85/71	35.0	27.1	42.1	2.26	15.5		80	41.1	32.0	2.72	4.4		
	12	4.2 (9.7)	75/63	31.3	24.9	38.2	2.23	14.1		60	44.7	37.5	2.17	6.0		
			80/67	33.4	26.5	40.3	2.20	15.2		70	43.5	35.4	2.43	5.2		
			85/71	35.7	27.2	42.6	2.17	16.4		80	42.4	33.3	2.72	4.6		
90	6	1.2 (2.7)	75/63	29.2	24.0	37.1	2.52	11.6	80	1.3 (2.9)	60	46.0	38.9	2.17	6.2	
			80/67	31.3	25.6	39.1	2.50	12.5			70	44.9	36.9	2.43	5.4	
			85/71	33.4	26.4	41.2	2.48	13.5			80	43.9	35.0	2.72	4.7	
	8	2.0 (4.6)	75/63	29.7	24.2	37.4	2.44	12.2		60	47.6	40.5	2.16	6.5		
			80/67	31.8	25.9	39.4	2.42	13.1		70	46.4	38.4	2.42	5.6		
			85/71	34.0	26.7	41.6	2.39	14.2		80	45.4	36.3	2.71	4.9		
	12	4.1 (9.5)	75/63	30.3	24.5	37.7	2.36	12.8		60	49.4	42.3	2.14	6.8		
			80/67	32.4	26.1	39.7	2.34	13.9		70	48.0	40.0	2.41	5.8		
			85/71	34.6	27.0	41.9	2.31	15.0		80	46.7	37.7	2.70	5.1		
100	6	1.2 (2.7)	75/63	27.4	23.1	36.2	2.83	9.7	Extended Range - Anti-freeze required	AHRI/ISO 13256-1 certified performance is rated at entering air conditions of 80.6°F DB and 66.2°F WB in cooling and 68°F DB in heating. Tabulated unit performance does not include fan or pump power corrections required for AHRI/ISO standard performance ratings. Unit performance may be interpolated. Extrapolation is not allowed. For conditions other than rating conditions provided, consult the BST selection software. Ratings below 40°F are with a methanol solution. The results reported herein are estimates based on testing by FHP. Variations in the installation and operational environment may alter performance. Bosch disclaims all warranties, express and implied, that the performance will be as reported, including the warranty of merchantability and fitness for purpose. In addition, continuous research and development may result in a change to an appliances design and specifications, which Bosch may change without notice. Before purchase, confirm the design specifications of the appliance.	1.3 (2.9)	60	46.0	38.9	2.17	6.2
			80/67	29.3	24.0	38.1	2.81	10.4				70	44.9	36.9	2.43	5.4
			85/71	31.4	25.0	40.1	2.78	11.3				80	43.9	35.0	2.72	4.7
	8	2.0 (4.5)	75/63	27.8	23.4	36.4	2.75	10.1			60	47.6	40.5	2.16	6.5	
			80/67	29.8	24.4	38.3	2.73	10.9			70	46.4	38.4	2.42	5.6	
			85/71	31.9	25.4	40.4	2.69	11.9			80	45.4	36.3	2.71	4.9	
	12	4.0 (9.2)	75/63	28.3	23.6	36.7	2.67	10.6			60	49.4	42.3	2.14	6.8	
			80/67	30.4	24.5	38.6	2.64	11.5			70	48.0	40.0	2.41	5.8	
			85/71	32.5	26.2	40.7	2.60	12.5			80	46.7	37.7	2.70	5.1	
110	6	1.1 (2.6)	75/63	25.5	22.3	35.4	3.19	8.0	Extended Range - Anti-freeze required	AHRI/ISO 13256-1 certified performance is rated at entering air conditions of 80.6°F DB and 66.2°F WB in cooling and 68°F DB in heating. Tabulated unit performance does not include fan or pump power corrections required for AHRI/ISO standard performance ratings. Unit performance may be interpolated. Extrapolation is not allowed. For conditions other than rating conditions provided, consult the BST selection software. Ratings below 40°F are with a methanol solution. The results reported herein are estimates based on testing by FHP. Variations in the installation and operational environment may alter performance. Bosch disclaims all warranties, express and implied, that the performance will be as reported, including the warranty of merchantability and fitness for purpose. In addition, continuous research and development may result in a change to an appliances design and specifications, which Bosch may change without notice. Before purchase, confirm the design specifications of the appliance.	1.3 (2.9)	60	46.0	38.9	2.17	6.2
			80/67	27.4	23.3	37.3	3.16	8.7				70	44.9	36.9	2.43	5.4
			85/71	29.4	24.2	39.2	3.12	9.4				80	43.9	35.0	2.72	4.7
	8	4.3 (1.9)	75/63	25.9	22.5	35.6	3.11	8.3			60	47.6	40.5	2.16	6.5	
			80/67	27.9	23.5	37.5	3.07	9.1			70	46.4	38.4	2.42	5.6	
			85/71	29.9	24.5	39.4	3.02	9.9			80	45.4	36.3	2.71	4.9	
	12	3.9 (9)	75/63	26.3	22.7	35.7	3.02	8.7			60	49.4	42.3	2.14	6.8	
			80/67	28.4	23.7	37.7	2.98	9.5			70	48.0	40.0	2.41	5.8	
			85/71	30.4	24.7	39.6	2.93	10.4			80	46.7	37.7	2.70	5.1	



Capacity Data

ES049 – Full Load (1700 CFM)

Cooling									Heating						
Entering Fluid Temp (°F)	Water Flow (GPM)	Pressure Drop PSI (FOH)	Entering Air Temp (db/wb) °F	Total Capacity (MBTUH)	Sensible Capacity (MBTUH)	Heat of Rejection (MBTUH)	Power Input (kW)	EER	Entering Fluid Temp (°F)	Pressure Drop PSI (FOH)	Entering Air Temp (°F)	Total Capacity (MBTUH)	Heat of Absorption (MBTUH)	Power Input (kW)	COP
50	6	1.3 (3.1)	75/63	50.0	38.3	59.8	3.01	16.6	30	1.5 (3.5)	60	34.5	24.7	2.96	3.4
			80/67	53.3	39.6	63.3	3.05	17.5			70	34.1	23.4	3.22	3.1
			85/71	56.8	40.8	66.9	3.09	18.4			80	33.8	22.1	3.50	2.8
	8	2.3 (5.2)	75/63	51.1	38.8	60.6	2.90	17.6		2.5 (5.8)	60	35.8	26.0	2.99	3.5
			80/67	54.6	40.2	64.2	2.93	18.6			70	35.4	24.5	3.25	3.2
			85/71	58.2	41.4	68.0	2.96	19.6			80	35.0	23.2	3.53	2.9
	12	4.7 (10.9)	75/63	52.4	39.4	61.5	2.78	18.8		5.3 (12.1)	60	37.3	27.3	3.03	3.6
			80/67	56.0	40.7	65.3	2.81	19.9			70	36.8	26.0	3.29	3.3
			85/71	59.8	42.0	69.1	2.84	21.1			80	36.3	24.5	3.57	3.0
60	6	1.3 (3)	75/63	47.8	37.3	58.3	3.22	14.8	40	1.5 (3.4)	60	39.0	28.9	3.07	3.7
			80/67	51.1	38.6	61.7	3.26	15.7			70	38.6	27.5	3.33	3.4
			85/71	54.3	39.9	65.1	3.29	16.5			80	38.1	26.1	3.62	3.1
	8	2.2 (5.1)	75/63	48.9	37.8	59.1	3.11	15.7		2.4 (5.6)	60	40.7	30.2	3.11	3.8
			80/67	52.3	39.2	62.6	3.14	16.6			70	40.1	28.7	3.37	3.5
			85/71	55.8	40.4	66.2	3.17	17.6			80	39.6	27.2	3.65	3.2
	12	4.6 (10.5)	75/63	50.1	38.4	59.9	3.00	16.7		5.1 (11.7)	60	42.6	32.0	3.15	4.0
			80/67	53.6	39.7	63.5	3.02	17.7			70	41.8	30.6	3.41	3.6
			85/71	57.4	40.7	67.4	3.05	18.8			80	41.3	29.0	3.69	3.3
70	6	1.3 (2.9)	75/63	45.6	36.3	56.7	3.45	13.2	50	1.4 (3.2)	60	44.1	33.4	3.18	4.1
			80/67	48.7	37.7	60.0	3.49	14.0			70	43.3	32.0	3.44	3.7
			85/71	51.9	38.8	63.4	3.52	14.7			80	42.8	30.5	3.73	3.4
	8	2.1 (4.9)	75/63	46.6	36.8	57.4	3.34	14.0		2.3 (5.4)	60	45.9	35.3	3.23	4.2
			80/67	49.9	38.1	60.8	3.37	14.8			70	45.2	33.7	3.48	3.8
			85/71	53.4	39.1	64.5	3.40	15.7			80	44.6	31.9	3.77	3.5
	12	4.4 (10.2)	75/63	47.8	37.3	58.2	3.22	14.8		4.9 (11.3)	60	48.3	37.6	3.28	4.3
			80/67	51.3	38.4	61.8	3.25	15.8			70	47.7	35.7	3.53	4.0
			85/71	54.8	39.7	65.5	3.27	16.7			80	46.6	34.0	3.82	3.6
80	6	1.2 (2.8)	75/63	43.2	35.3	55.2	3.71	11.6	60	1.3 (3.1)	60	49.2	38.5	3.29	4.4
			80/67	46.4	36.4	58.5	3.75	12.4			70	48.5	36.8	3.56	4.0
			85/71	49.3	37.9	61.6	3.78	13.0			80	47.9	35.2	3.85	3.6
	8	2.0 (4.7)	75/63	44.3	35.7	55.9	3.59	12.3		2.3 (5.2)	60	51.6	40.8	3.34	4.5
			80/67	47.5	36.9	59.2	3.62	13.1			70	50.9	39.0	3.61	4.1
			85/71	50.6	38.4	62.5	3.65	13.9			80	50.0	37.1	3.90	3.8
	12	4.3 (9.8)	75/63	45.4	36.1	56.6	3.47	13.1		4.7 (10.9)	60	54.4	43.4	3.40	4.7
			80/67	48.6	37.5	60.0	3.50	13.9			70	53.6	41.0	3.66	4.3
			85/71	51.9	38.9	63.4	3.52	14.8			80	52.4	38.8	3.96	3.9
85	6	1.2 (2.8)	75/63	42.1	34.7	54.5	3.85	10.9	70	1.3 (3)	60	54.6	43.4	3.41	4.7
			80/67	45.2	35.8	57.7	3.89	11.6			70	54.1	41.7	3.67	4.3
			85/71	48.0	37.4	60.7	3.93	12.2			80	53.2	40.1	3.98	3.9
	8	2.0 (4.7)	75/63	43.1	35.1	55.1	3.73	11.5		2.2 (5.1)	60	57.6	46.5	3.46	4.9
			80/67	46.3	36.3	58.4	3.76	12.3			70	56.6	44.4	3.73	4.4
			85/71	49.2	37.9	61.5	3.79	13.0			80	55.7	42.1	4.03	4.0
	12	4.2 (9.7)	75/63	44.1	35.6	55.8	3.61	12.2		4.6 (10.5)	60	60.9	49.6	3.52	5.1
			80/67	47.3	37.1	59.0	3.63	13.0			70	59.7	47.2	3.79	4.6
			85/71	50.7	38.1	62.6	3.65	13.9			80	58.8	44.7	4.10	4.2
90	6	1.2 (2.7)	75/63	40.9	34.2	53.8	4.01	10.2	80	1.3 (2.9)	60	60.8	49.4	3.52	5.1
			80/67	43.7	35.6	56.8	4.05	10.8			70	59.5	46.8	3.79	4.6
			85/71	46.7	36.8	60.0	4.08	11.4			80	58.6	45.2	4.10	4.2
	8	2.0 (4.6)	75/63	41.9	34.6	54.4	3.88	10.8		2.1 (4.9)	60	64.0	51.8	3.58	5.2
			80/67	44.8	36.0	57.5	3.91	11.4			70	62.6	50.2	3.86	4.8
			85/71	47.9	37.4	60.7	3.94	12.2			80	61.5	47.8	4.17	4.3
	12	4.1 (9.5)	75/63	43.0	34.8	55.1	3.76	11.4		4.4 (10.2)	60	67.7	56.0	3.65	5.4
			80/67	46.0	36.5	58.2	3.78	12.2			70	66.2	53.5	3.92	4.9
			85/71	49.2	37.8	61.6	3.80	12.9			80	64.8	50.9	4.24	4.5
100	6	1.2 (2.7)	75/63	38.4	33.0	52.4	4.36	8.8	<p>Extended Range - Anti-freeze required</p> <p>AHRI/ISO13256-1 certified performance is rated at entering air conditions of 80.6°F DB and 66.2°F WB in cooling and 68°F DB in heating.</p> <p>Tabulated unit performance does not include fan or pump power corrections required for AHRI/ISO standard performance ratings.</p> <p>Unit performance may be interpolated. Extrapolation is not allowed.</p> <p>For conditions other than rating conditions provided, consult the BST selection software.</p> <p>Ratings below 40°F are with a methanol solution.</p> <p>The results reported herein are estimates based on testing by FHP. Variations in the installation and operational environment may alter performance. Bosch disclaims all warranties, express and implied, that the performance will be as reported, including the warranty of merchantability and fitness for purpose. In addition, continuous research and development may result in a change to an appliances design and specifications, which Bosch may change without notice. Before purchase, confirm the design specifications of the appliance.</p>						
			80/67	41.2	34.5	55.3	4.40	9.4							
			85/71	44.0	35.8	58.3	4.44	9.9							
	8	2.0 (4.5)	75/63	39.4	33.4	52.9	4.23	9.3							
			80/67	42.2	34.9	55.9	4.25	9.9							
			85/71	45.2	36.2	59.0	4.28	10.6							
	12	4.0 (9.2)	75/63	40.3	33.9	53.4	4.09	9.8							
			80/67	43.3	35.3	56.5	4.11	10.5							
			85/71	46.5	36.4	59.9	4.13	11.3							
110	6	1.1 (2.6)	75/63	36.1	31.9	51.3	4.76	7.6							
			80/67	38.6	33.3	54.1	4.81	8.0							
			85/71	41.2	34.7	56.9	4.85	8.5							
	8	4.3 (1.9)	75/63	36.9	32.2	51.7	4.63	8.0							
			80/67	39.5	33.7	54.5	4.66	8.5							
			85/71	42.3	35.0	57.5	4.68	9.0							
	12	3.9 (9)	75/63	37.7	32.6	52.1	4.49	8.4							
			80/67	40.5	34.1	55.0	4.51	9.0							
			85/71	43.5	35.4	58.1	4.52	9.6							

Extended Range - Anti-freeze required

AHRI/ISO13256-1 certified performance is rated at entering air conditions of 80.6°F DB and 66.2°F WB in cooling and 68°F DB in heating.

Tabulated unit performance does not include fan or pump power corrections required for AHRI/ISO standard performance ratings.

Unit performance may be interpolated. Extrapolation is not allowed.

For conditions other than rating conditions provided, consult the BST selection software.

Ratings below 40°F are with a methanol solution.

The results reported herein are estimates based on testing by FHP. Variations in the installation and operational environment may alter performance. Bosch disclaims all warranties, express and implied, that the performance will be as reported, including the warranty of merchantability and fitness for purpose. In addition, continuous research and development may result in a change to an appliances design and specifications, which Bosch may change without notice. Before purchase, confirm the design specifications of the appliance.



Capacity Data

ES061 – Part Load (1500 CFM)

Cooling									Heating						
Entering Fluid Temp (°F)	Water Flow (GPM)	Pressure Drop PSI (FOH)	Entering Air Temp (db/wb) °F	Total Capacity (MBTUH)	Sensible Capacity (MBTUH)	Heat of Rejection (MBTUH)	Power Input (kW)	EER	Entering Fluid Temp (°F)	Pressure Drop PSI (FOH)	Entering Air Temp (°F)	Total Capacity (MBTUH)	Heat of Absorption (MBTUH)	Power Input (kW)	COP
50	7.5	1.4 (3.3)	75/63	49.5	37.7	56.1	2.02	24.5	30	1.6 (3.7)	60	35.3	26.0	2.85	3.6
			80/67	53.0	38.9	59.6	2.01	26.4			70	35.1	24.5	3.24	3.2
			85/71	56.6	40.0	63.2	2.01	28.2			80	35.0	22.9	3.69	2.8
	10	2.4 (5.5)	75/63	50.2	38.0	56.5	1.92	26.1		60	36.2	26.9	2.85	3.7	
			80/67	53.8	39.2	60.1	1.91	28.1		70	35.9	25.3	3.25	3.2	
			85/71	57.5	40.4	63.8	1.90	30.2		80	35.8	23.7	3.69	2.8	
	15	5.0 (11.5)	75/63	50.6	37.5	56.9	1.90	26.6		60	37.2	27.9	2.86	3.8	
			80/67	54.2	38.7	60.5	1.90	28.6		70	36.9	26.2	3.25	3.3	
			85/71	58.3	40.7	64.1	1.76	33.0		80	36.7	24.5	3.69	2.9	
60	7.5	1.4 (3.2)	75/63	47.5	36.8	54.9	2.30	20.7	40	1.5 (3.5)	60	40.1	30.7	2.87	4.1
			80/67	50.9	37.9	58.3	2.29	22.3			70	39.8	29.0	3.27	3.6
			85/71	54.3	39.2	61.7	2.27	23.9			80	39.6	27.4	3.71	3.1
	10	2.3 (5.3)	75/63	48.1	37.1	55.2	2.21	21.8		60	41.3	31.9	2.88	4.2	
			80/67	51.6	38.3	58.7	2.19	23.5		70	40.9	30.1	3.27	3.7	
			85/71	55.1	39.5	62.3	2.18	25.3		80	40.6	28.3	3.72	3.2	
	15	4.8 (11.1)	75/63	48.7	37.4	55.6	2.11	23.1		60	42.8	33.2	2.88	4.4	
			80/67	52.2	38.6	59.0	2.08	25.1		70	42.2	31.3	3.27	3.8	
			85/71	55.7	38.8	62.9	2.15	25.9		80	41.7	29.4	3.72	3.3	
70	7.5	1.3 (3.1)	75/63	45.4	35.8	53.7	2.60	17.4	50	1.5 (3.4)	60	45.5	36.0	2.89	4.6
			80/67	48.5	37.2	56.9	2.58	18.8			70	45.0	34.2	3.27	4.0
			85/71	52.0	38.2	60.4	2.56	20.3			80	44.6	32.4	3.71	3.5
	10	2.3 (5.2)	75/63	45.9	36.2	54.0	2.51	18.3		60	47.0	37.4	2.90	4.8	
			80/67	49.2	37.4	57.3	2.49	19.7		70	46.4	35.6	3.28	4.2	
			85/71	52.8	38.5	60.8	2.47	21.4		80	46.0	33.6	3.71	3.6	
	15	4.6 (10.7)	75/63	46.2	36.3	54.2	2.47	18.7		60	48.8	39.1	2.91	4.9	
			80/67	49.6	37.5	57.5	2.45	20.2		70	48.0	37.0	3.28	4.3	
			85/71	53.1	38.5	61.1	2.43	21.9		80	47.3	35.0	3.71	3.7	
80	7.5	1.3 (3)	75/63	43.1	35.0	52.5	2.93	14.7	60	1.4 (3.3)	60	51.3	41.7	2.92	5.1
			80/67	46.3	36.3	55.6	2.90	15.9			70	50.6	39.7	3.30	4.5
			85/71	49.6	37.4	58.9	2.88	17.2			80	50.1	37.8	3.72	3.9
	10	2.2 (5)	75/63	43.6	34.7	52.9	2.89	15.1		60	53.1	43.5	2.93	5.3	
			80/67	46.8	36.5	55.8	2.80	16.7		70	52.3	41.4	3.31	4.6	
			85/71	50.2	37.7	59.2	2.78	18.0		80	51.7	39.3	3.73	4.1	
	15	4.5 (10.4)	75/63	44.1	35.3	53.0	2.79	15.8		60	55.3	45.4	2.94	5.5	
			80/67	47.4	36.5	56.3	2.76	17.2		70	54.3	43.1	3.32	4.8	
			85/71	50.7	37.9	59.5	2.73	18.6		80	53.3	40.9	3.74	4.2	
85	7.5	1.3 (2.9)	75/63	42.0	34.6	51.9	3.12	13.5	70	1.4 (3.2)	60	57.5	47.8	2.96	5.7
			80/67	45.1	35.7	55.0	3.09	14.6			70	56.6	45.6	3.33	5.0
			85/71	48.3	37.1	58.1	3.05	15.8			80	55.9	43.4	3.75	4.4
	10	2.1 (4.9)	75/63	42.5	34.8	52.1	3.02	14.1		60	59.6	49.9	2.97	5.9	
			80/67	45.6	35.6	55.3	3.04	15.0		70	58.6	47.5	3.34	5.1	
			85/71	48.9	36.6	58.6	3.01	16.2		80	57.7	45.2	3.77	4.5	
	15	4.4 (10.2)	75/63	43.0	34.9	52.5	2.97	14.5		60	62.1	52.2	2.99	6.1	
			80/67	46.2	36.1	55.6	2.93	15.8		70	60.8	49.7	3.36	5.3	
			85/71	49.4	37.5	58.8	2.89	17.1		80	59.7	47.1	3.78	4.6	
90	7.5	1.3 (2.9)	75/63	40.9	34.1	51.4	3.31	12.3	80	1.3 (3.1)	60	64.0	54.1	3.00	6.2
			80/67	44.0	35.3	54.5	3.28	13.4			70	62.9	51.7	3.37	5.5
			85/71	47.0	36.6	57.5	3.24	14.5			80	62.0	49.3	3.80	4.8
	10	2.1 (4.9)	75/63	41.4	34.3	51.6	3.22	12.8		60	66.5	56.5	3.02	6.4	
			80/67	44.4	35.3	54.7	3.22	13.8		70	65.2	54.0	3.39	5.6	
			85/71	47.6	36.8	57.7	3.13	15.2		80	64.1	51.4	3.81	4.9	
	15	4.4 (10.1)	75/63	41.9	34.4	51.9	3.15	13.3		60	69.4	59.2	3.05	6.7	
			80/67	44.9	35.8	54.9	3.11	14.4		70	67.8	56.3	3.41	5.8	
			85/71	48.2	37.0	58.1	3.07	15.7		80	66.5	53.4	3.83	5.1	
100	7.5	1.2 (2.8)	75/63	38.7	33.0	50.7	3.77	10.2	100	1.2 (2.8)	60	66.5	53.4	3.83	5.1
			80/67	41.5	34.5	53.3	3.71	11.2			70	62.9	51.7	3.37	5.5
			85/71	44.5	35.7	56.2	3.67	12.1			80	62.0	49.3	3.80	4.8
	10	2.0 (4.7)	75/63	39.0	33.3	50.7	3.69	10.6		60	66.5	56.5	3.02	6.4	
			80/67	41.9	34.6	53.5	3.64	11.5		70	65.2	54.0	3.39	5.6	
			85/71	45.2	35.4	56.7	3.59	12.6		80	64.1	51.4	3.81	4.9	
	15	4.3 (9.8)	75/63	39.6	33.6	51.0	3.56	11.1		60	69.4	59.2	3.05	6.7	
			80/67	42.6	34.9	53.8	3.51	12.1		70	67.8	56.3	3.41	5.8	
			85/71	45.8	36.0	56.9	3.46	13.2		80	66.5	53.4	3.83	5.1	
110	7.5	1.2 (2.7)	75/63	36.3	32.3	49.9	4.28	8.5	110	1.2 (2.7)	60	66.5	53.4	3.83	5.1
			80/67	39.1	33.3	52.6	4.25	9.2			70	62.9	51.7	3.37	5.5
			85/71	41.9	34.9	55.3	4.18	10.0			80	62.0	49.3	3.80	4.8
	10	2.0 (4.6)	75/63	36.9	32.4	50.1	4.15	8.9		60	66.5	56.5	3.02	6.4	
			80/67	39.7	33.7	52.8	4.11	9.7		70	65.2	54.0	3.39	5.6	
			85/71	42.5	35.1	55.5	4.06	10.5		80	64.1	51.4	3.81	4.9	
	15	4.1 (9.5)	75/63	37.4	32.7	50.2	4.03	9.3		60	69.4	59.2	3.05	6.7	
			80/67	40.3	33.9	53.0	3.98	10.1		70	67.8	56.3	3.41	5.8	
			85/71	43.3	35.2	55.8	3.92	11.0		80	66.5	53.4	3.83	5.1	

Extended Range - Anti-freeze required
 AHRI/ISO13256-1 certified performance is rated at entering air conditions of 80.6°F DB and 66.2°F WB in cooling and 68°F DB in heating.
 Tabulated unit performance does not include fan or pump power corrections required for AHRI/ISO standard performance ratings.
 Unit performance may be interpolated. Extrapolation is not allowed.
 For conditions other than rating conditions provided, consult the BST selection software.
 Ratings below 40°F are with a methanol solution.
 The results reported herein are estimates based on testing by FHP. Variations in the installation and operational environment may alter performance. Bosch disclaims all warranties, express and implied, that the performance will be as reported, including the warranty of merchantability and fitness for purpose. In addition, continuous research and development may result in a change to an appliances design and specifications, which Bosch may change without notice. Before purchase, confirm the design specifications of the appliance.



Capacity Data

ES061 – Full Load (2000 CFM)

Cooling									Heating							
Entering Fluid Temp (°F)	Water Flow (GPM)	Pressure Drop PSI (FOH)	Entering Air Temp (db/wb) °F	Total Capacity (MBTUH)	Sensible Capacity (MBTUH)	Heat of Rejection (MBTUH)	Power Input (kW)	EER	Entering Fluid Temp (°F)	Pressure Drop PSI (FOH)	Entering Air Temp (°F)	Total Capacity (MBTUH)	Heat of Absorption (MBTUH)	Power Input (kW)	COP	
50	9	1.4 (3.3)	75/63	64.3	47.8	76.6	3.71	17.3	30	1.6 (3.7)	60	47.6	34.0	4.13	3.4	
			80/67	68.8	48.9	81.4	3.78	18.2			70	47.3	32.1	4.52	3.1	
			85/71	73.3	50.2	86.2	3.85	19.1			80	46.5	30.1	4.97	2.7	
	12	2.4 (5.5)	75/63	65.7	48.0	77.5	3.56	18.5		60	49.4	35.4	4.16	3.5		
			80/67	70.2	49.5	82.3	3.61	19.5		70	48.8	33.4	4.56	3.1		
			85/71	74.9	50.8	87.2	3.66	20.5		80	47.9	31.4	5.00	2.8		
	18	5.0 (11.5)	75/63	66.8	48.9	78.1	3.40	19.7		60	51.3	37.0	4.20	3.6		
			80/67	71.5	50.4	83.0	3.43	20.8		70	50.5	34.9	4.60	3.2		
			85/71	76.3	52.2	87.9	3.46	22.1		80	49.4	32.8	5.03	2.9		
60	9	1.4 (3.2)	75/63	61.8	46.3	75.2	4.06	15.2	40	1.5 (3.5)	60	54.3	39.9	4.27	3.7	
			80/67	66.0	47.8	79.7	4.12	16.0			70	53.6	37.9	4.68	3.4	
			85/71	70.3	49.4	84.2	4.18	16.8			80	52.8	35.9	5.11	3.0	
	12	2.3 (5.3)	75/63	63.0	46.8	75.9	3.91	16.1		60	56.3	41.8	4.32	3.8		
			80/67	67.4	48.3	80.5	3.95	17.1		70	55.5	39.6	4.72	3.4		
			85/71	71.8	50.0	85.2	4.00	18.0		80	54.8	37.4	5.16	3.1		
	18	4.8 (11.1)	75/63	63.8	46.1	76.6	3.86	16.5		60	58.7	43.8	4.37	3.9		
			80/67	68.6	49.2	81.2	3.79	18.1		70	57.7	41.4	4.77	3.5		
			85/71	73.3	51.0	86.0	3.80	19.3		80	56.8	39.1	5.21	3.2		
70	9	1.3 (3.1)	75/63	59.1	45.1	73.6	4.43	13.4	50	1.5 (3.4)	60	61.2	46.5	4.43	4.0	
			80/67	63.2	46.6	78.0	4.49	14.1			70	60.5	44.3	4.85	3.7	
			85/71	67.4	48.1	82.4	4.55	14.8			80	59.8	42.1	5.30	3.3	
	12	2.3 (5.2)	75/63	60.2	45.5	74.3	4.28	14.1		60	63.9	48.9	4.49	4.2		
			80/67	64.3	47.4	78.6	4.31	14.9		70	62.9	46.5	4.91	3.8		
			85/71	68.8	48.6	83.3	4.37	15.8		80	62.0	44.1	5.36	3.4		
	18	4.6 (10.7)	75/63	61.0	47.0	74.5	4.10	14.9		60	66.9	51.4	4.56	4.3		
			80/67	65.3	49.2	78.8	4.10	15.9		70	65.7	48.9	4.98	3.9		
			85/71	70.0	50.4	83.8	4.15	16.9		80	64.5	46.4	5.43	3.5		
80	9	1.3 (3)	75/63	56.2	43.9	72.1	4.83	11.6	60	1.4 (3.3)	60	69.2	53.8	4.61	4.4	
			80/67	60.2	45.5	76.2	4.89	12.3			70	68.3	51.5	5.04	4.0	
			85/71	64.2	47.1	80.5	4.94	13.0			80	67.5	49.1	5.51	3.6	
	12	2.2 (5)	75/63	57.3	44.3	72.6	4.68	12.2		60	72.2	56.6	4.68	4.5		
			80/67	61.3	46.1	76.9	4.72	13.0		70	71.0	54.0	5.11	4.1		
			85/71	65.7	47.3	81.4	4.77	13.8		80	70.0	51.3	5.58	3.7		
	18	4.5 (10.4)	75/63	58.0	45.9	72.8	4.49	12.9		60	75.8	59.6	4.77	4.7		
			80/67	62.2	48.0	77.0	4.51	13.8		70	74.4	56.7	5.20	4.2		
			85/71	66.8	48.8	81.8	4.56	14.6		80	73.0	54.0	5.67	3.8		
85	9	1.3 (2.9)	75/63	54.8	43.3	71.3	5.05	10.9	70	1.4 (3.2)	60	77.3	61.3	4.81	4.7	
			80/67	58.7	44.8	75.4	5.10	11.5			70	76.4	58.9	5.25	4.3	
			85/71	62.7	46.2	79.7	5.17	12.1			80	75.4	56.3	5.74	3.8	
	12	2.1 (4.9)	75/63	55.8	43.6	71.9	4.91	11.4		60	81.1	64.7	4.90	4.8		
			80/67	59.8	45.4	76.0	4.94	12.1		70	79.8	62.1	5.35	4.4		
			85/71	64.0	46.7	80.4	4.99	12.8		80	78.6	59.2	5.84	3.9		
	18	4.4 (10.2)	75/63	56.5	45.2	71.9	4.71	12.0		60	85.3	68.3	5.00	5.0		
			80/67	60.6	47.2	76.1	4.73	12.8		70	83.7	65.0	5.45	4.5		
			85/71	65.0	46.6	81.1	4.89	13.3		80	82.2	61.8	5.94	4.1		
90	9	1.3 (2.9)	75/63	53.3	42.9	70.5	5.27	10.1	80	1.3 (3.1)	60	86.2	69.4	5.03	5.0	
			80/67	57.0	44.6	74.5	5.32	10.7			70	84.9	66.6	5.49	4.5	
			85/71	61.1	45.6	78.8	5.39	11.3			80	83.6	63.5	5.99	4.1	
	12	2.1 (4.9)	75/63	54.2	43.4	70.9	5.12	10.6		60	90.5	73.4	5.14	5.2		
			80/67	58.2	44.8	75.1	5.17	11.3		70	88.9	70.3	5.60	4.6		
			85/71	62.2	46.4	79.4	5.21	11.9		80	87.4	67.2	6.11	4.2		
	18	4.4 (10.1)	75/63	54.7	43.7	71.2	5.03	10.9		60	95.3	77.4	5.27	5.3		
			80/67	58.9	45.0	75.6	5.07	11.6		70	93.4	73.7	5.73	4.8		
			85/71	63.3	47.4	79.8	5.02	12.6		80	91.7	70.0	6.24	4.3		
100	9	1.2 (2.8)	75/63	50.4	41.3	69.2	5.78	8.7	Extended Range - Anti-freeze required	AHR/ISO13256-1 certified performance is rated at entering air conditions of 80.6°F DB and 66.2°F WB in cooling and 68°F DB in heating. Tabulated unit performance does not include fan or pump power corrections required for AHR/ISO standard performance ratings. Unit performance may be interpolated. Extrapolation is not allowed. For conditions other than rating conditions provided, consult the BST selection software. Ratings below 40°F are with a methanol solution. The results reported herein are estimates based on testing by FHP. Variations in the installation and operational environment may alter performance. Bosch disclaims all warranties, express and implied, that the performance will be as reported, including the warranty of merchantability and fitness for purpose. In addition, continuous research and development may result in a change to an appliances design and specifications, which Bosch may change without notice. Before purchase, confirm the design specifications of the appliance.	1.3 (3.1)	60	86.2	69.4	5.03	5.0
			80/67	54.0	43.0	73.0	5.83	9.3				70	84.9	66.6	5.49	4.5
			85/71	57.5	45.2	76.7	5.88	9.8				80	83.6	63.5	5.99	4.1
	12	2.0 (4.7)	75/63	51.1	41.8	69.5	5.64	9.1			60	90.5	73.4	5.14	5.2	
			80/67	54.8	43.9	73.3	5.66	9.7			70	88.9	70.3	5.60	4.6	
			85/71	58.7	45.6	77.4	5.70	10.3			80	87.4	67.2	6.11	4.2	
	18	4.3 (9.8)	75/63	51.8	42.5	69.7	5.50	9.4			60	95.3	77.4	5.27	5.3	
			80/67	55.6	44.1	73.7	5.54	10.1			70	93.4	73.7	5.73	4.8	
			85/71	59.8	45.3	78.1	5.58	10.7			80	91.7	70.0	6.24	4.3	
110	9	1.2 (2.7)	75/63	47.2	40.4	67.8	6.33	7.5	AHR/ISO13256-1 certified performance is rated at entering air conditions of 80.6°F DB and 66.2°F WB in cooling and 68°F DB in heating. Tabulated unit performance does not include fan or pump power corrections required for AHR/ISO standard performance ratings. Unit performance may be interpolated. Extrapolation is not allowed. For conditions other than rating conditions provided, consult the BST selection software. Ratings below 40°F are with a methanol solution. The results reported herein are estimates based on testing by FHP. Variations in the installation and operational environment may alter performance. Bosch disclaims all warranties, express and implied, that the performance will be as reported, including the warranty of merchantability and fitness for purpose. In addition, continuous research and development may result in a change to an appliances design and specifications, which Bosch may change without notice. Before purchase, confirm the design specifications of the appliance.	2.0 (4.6)	60	95.3	77.4	5.27	5.3	
			80/67	50.6	42.1	71.5	6.39	7.9			70	93.4	73.7	5.73	4.8	
			85/71	54.3	43.6	75.4	6.46	8.4			80	91.7	70.0	6.24	4.3	
	12	2.0 (4.6)	75/63	47.9	40.6	68.2	6.21	7.7		60	95.3	77.4	5.27	5.3		
			80/67	51.5	42.5	71.9	6.24	8.3		70	93.4	73.7	5.73	4.8		
			85/71	55.2	44.1	75.8	6.28	8.8		80	91.7	70.0	6.24	4.3		
	18	4.1 (9.5)	75/63	48.8	41.1	68.4	6.03	8.1		60	95.3	77.4	5.27	5.3		
			80/67	52.6	42.5	72.5	6.07	8.7		70	93.4	73.7	5.73	4.8		
			85/71	56.1	44.5	76.1	6.12	9.2		80	91.7	70.0	6.24	4.3		

Extended Range - Anti-freeze required
 AHR/ISO13256-1 certified performance is rated at entering air conditions of 80.6°F DB and 66.2°F WB in cooling and 68°F DB in heating.
 Tabulated unit performance does not include fan or pump power corrections required for AHR/ISO standard performance ratings.
 Unit performance may be interpolated. Extrapolation is not allowed.
 For conditions other than rating conditions provided, consult the BST selection software.
 Ratings below 40°F are with a methanol solution.
 The results reported herein are estimates based on testing by FHP. Variations in the installation and operational environment may alter performance. Bosch disclaims all warranties, express and implied, that the performance will be as reported, including the warranty of merchantability and fitness for purpose. In addition, continuous research and development may result in a change to an appliances design and specifications, which Bosch may change without notice. Before purchase, confirm the design specifications of the appliance.



Capacity Data

ES071 – Part Load (1600 CFM)

Cooling									Heating							
Entering Fluid Temp (°F)	Water Flow (GPM)	Pressure Drop PSI (FOH)	Entering Air Temp (db/wb) °F	Total Capacity (MBTUH)	Sensible Capacity (MBTUH)	Heat of Rejection (MBTUH)	Power Input (kW)	EER	Entering Fluid Temp (°F)	Pressure Drop PSI (FOH)	Entering Air Temp (°F)	Total Capacity (MBTUH)	Heat of Absorption (MBTUH)	Power Input (kW)	COP	
50	9	2.0 (4.7)	75/63	57.6	42.2	66.0	2.53	22.8	30	2.3 (5.3)	60	39.9	28.5	3.51	3.3	
			80/67	61.7	43.5	70.1	2.53	24.4			70	39.7	26.7	3.94	3.0	
			85/71	66.0	44.6	74.4	2.53	26.1			80	39.7	24.9	4.41	2.6	
	12	8 (3.5)	75/63	58.5	42.6	66.5	2.42	24.2		60	40.9	29.4	3.51	3.4		
			80/67	62.7	43.9	70.8	2.42	25.9		70	40.5	27.6	3.94	3.0		
			85/71	67.1	45.0	75.2	2.41	27.8		80	40.6	25.6	4.42	2.7		
	18	16.5 (7.2)	75/63	59.3	43.0	67.0	2.31	25.7		60	42.0	30.4	3.52	3.5		
			80/67	63.7	44.3	71.4	2.30	27.7		70	41.5	28.4	3.95	3.1		
			85/71	68.2	45.6	75.9	2.29	29.8		80	41.3	26.5	4.43	2.7		
60	9	4.6 (2)	75/63	55.1	41.2	64.4	2.83	19.5	40	2.2 (5.1)	60	45.5	33.7	3.55	3.8	
			80/67	59.1	42.5	68.4	2.82	20.9			70	45.2	31.8	3.99	3.3	
			85/71	63.3	43.6	72.6	2.82	22.5			80	44.8	29.9	4.46	2.9	
	12	7.7 (3.3)	75/63	56.0	41.6	64.9	2.73	20.5		60	46.7	35.0	3.57	3.8		
			80/67	60.1	42.9	69.0	2.71	22.2		70	46.1	33.0	4.00	3.4		
			85/71	64.3	44.1	73.2	2.70	23.8		80	45.6	31.0	4.47	3.0		
	18	16 (6.9)	75/63	56.8	42.0	65.4	2.62	21.7		60	48.1	36.3	3.58	3.9		
			80/67	61.0	43.3	69.6	2.60	23.4		70	47.4	34.1	4.01	3.5		
			85/71	65.4	44.5	74.0	2.59	25.3		80	46.8	31.9	4.48	3.1		
70	9	1.9 (4.4)	75/63	52.7	40.0	62.9	3.15	16.7	50	2.1 (4.9)	60	51.6	39.6	3.61	4.2	
			80/67	56.5	41.3	66.8	3.14	18.0			70	51.0	37.5	4.04	3.7	
			85/71	60.4	42.7	70.7	3.12	19.4			80	50.4	35.4	4.52	3.3	
	12	3.2 (7.4)	75/63	53.4	40.4	63.3	3.05	17.5		60	53.1	41.1	3.62	4.3		
			80/67	57.4	41.7	67.3	3.03	19.0		70	52.4	38.9	4.04	3.8		
			85/71	61.5	43.0	71.4	3.01	20.5		80	51.8	36.6	4.53	3.4		
	18	6.7 (15.4)	75/63	54.2	40.8	63.8	2.95	18.4		60	54.9	42.8	3.63	4.4		
			80/67	58.3	42.1	67.9	2.92	20.0		70	53.9	40.4	4.05	3.9		
			85/71	62.6	43.3	72.1	2.89	21.6		80	53.2	38.0	4.53	3.4		
80	9	1.9 (4.3)	75/63	50.0	39.0	61.4	3.51	14.3	60	2.0 (4.7)	60	58.2	46.1	3.66	4.7	
			80/67	53.7	40.3	65.0	3.48	15.4			70	57.3	43.8	4.07	4.1	
			85/71	57.5	41.6	68.8	3.46	16.6			80	56.7	41.4	4.54	3.7	
	12	3.1 (7.2)	75/63	50.9	39.2	61.9	3.40	15.0		60	60.0	47.9	3.67	4.8		
			80/67	54.6	40.7	65.5	3.37	16.2		70	59.0	45.4	4.08	4.2		
			85/71	58.5	42.0	69.4	3.34	17.5		80	58.2	43.0	4.54	3.8		
	18	6.5 (15)	75/63	51.6	39.5	62.3	3.30	15.6		60	62.1	49.9	3.69	4.9		
			80/67	55.4	41.0	66.1	3.26	17.0		70	60.9	47.2	4.09	4.4		
			85/71	59.6	42.2	70.1	3.23	18.5		80	59.8	44.6	4.55	3.8		
85	9	1.8 (4.2)	75/63	48.7	38.4	60.6	3.70	13.2	70	2.0 (4.6)	60	65.1	52.9	3.71	5.1	
			80/67	52.4	39.7	64.3	3.67	14.3			70	64.0	50.3	4.12	4.6	
			85/71	56.0	41.1	67.9	3.64	15.4			80	63.1	47.8	4.58	4.0	
	12	3.1 (7.1)	75/63	49.4	38.7	61.0	3.59	13.8		60	67.3	55.0	3.73	5.3		
			80/67	53.2	40.0	64.8	3.55	15.0		70	66.0	52.3	4.14	4.7		
			85/71	57.0	41.4	68.5	3.52	16.2		80	64.9	49.6	4.59	4.1		
	18	6.4 (14.7)	75/63	50.2	39.0	61.4	3.48	14.4		60	69.8	57.4	3.75	5.5		
			80/67	54.0	40.4	65.2	3.44	15.7		70	68.2	54.4	4.15	4.8		
			85/71	57.9	41.8	69.1	3.40	17.0		80	66.8	51.4	4.61	4.2		
90	9	1.8 (4.2)	75/63	47.3	37.9	59.9	3.90	12.1	80	1.9 (4.4)	60	72.4	59.9	3.77	5.6	
			80/67	50.9	39.2	63.4	3.87	13.2			70	70.7	57.3	4.18	5.0	
			85/71	54.6	40.4	67.1	3.84	14.2			80	69.8	54.3	4.63	4.4	
	12	3.0 (7)	75/63	48.1	38.2	60.3	3.79	12.7		60	74.9	62.4	3.79	5.8		
			80/67	51.8	39.4	63.9	3.75	13.8		70	73.3	59.4	4.20	5.1		
			85/71	55.6	40.8	67.6	3.72	15.0		80	71.9	56.4	4.65	4.5		
	18	6.3 (14.5)	75/63	48.8	38.4	60.6	3.69	13.2		60	77.8	65.1	3.82	6.0		
			80/67	52.6	39.7	64.4	3.64	14.4		70	75.9	61.9	4.22	5.3		
			85/71	56.4	41.2	68.1	3.60	15.7		80	74.2	58.6	4.67	4.7		
100	9	1.7 (4)	75/63	44.6	36.7	58.6	4.36	10.2	Extended Range - Anti-freeze required	AHRI/ISO 13256-1 certified performance is rated at entering air conditions of 80.6°F DB and 66.2°F WB in cooling and 68°F DB in heating. Tabulated unit performance does not include fan or pump power corrections required for AHRI/ISO standard performance ratings. Unit performance may be interpolated. Extrapolation is not allowed. For conditions other than rating conditions provided, consult the BST selection software. Ratings below 40°F are with a methanol solution. The results reported herein are estimates based on testing by FHP. Variations in the installation and operational environment may alter performance. Bosch disclaims all warranties, express and implied, that the performance will be as reported, including the warranty of merchantability and fitness for purpose. In addition, continuous research and development may result in a change to an appliances design and specifications, which Bosch may change without notice. Before purchase, confirm the design specifications of the appliance.	3.0 (6.8)	60	75.4	63.4	3.82	6.0
			80/67	48.1	38.0	62.0	4.32	11.1				70	74.2	61.4	4.22	5.3
			85/71	51.6	39.3	65.4	4.28	12.1				80	73.0	59.4	4.67	4.7
	12	3.0 (6.8)	75/63	45.3	37.0	58.9	4.25	10.7			60	78.8	66.8	3.82	6.0	
			80/67	48.8	38.3	62.4	4.20	11.6			70	77.6	64.8	4.22	5.3	
			85/71	52.3	39.8	65.8	4.15	12.6			80	76.4	62.8	4.67	4.7	
	18	6.1 (14.1)	75/63	45.9	37.3	59.2	4.14	11.1			60	81.6	70.2	3.82	6.0	
			80/67	49.6	38.6	62.7	4.08	12.2			70	80.4	68.2	4.22	5.3	
			85/71	53.2	40.1	66.2	4.02	13.2			80	79.2	66.2	4.67	4.7	
110	9	1.7 (3.9)	75/63	42.0	35.7	57.6	4.88	8.6	Extended Range - Anti-freeze required	AHRI/ISO 13256-1 certified performance is rated at entering air conditions of 80.6°F DB and 66.2°F WB in cooling and 68°F DB in heating. Tabulated unit performance does not include fan or pump power corrections required for AHRI/ISO standard performance ratings. Unit performance may be interpolated. Extrapolation is not allowed. For conditions other than rating conditions provided, consult the BST selection software. Ratings below 40°F are with a methanol solution. The results reported herein are estimates based on testing by FHP. Variations in the installation and operational environment may alter performance. Bosch disclaims all warranties, express and implied, that the performance will be as reported, including the warranty of merchantability and fitness for purpose. In addition, continuous research and development may result in a change to an appliances design and specifications, which Bosch may change without notice. Before purchase, confirm the design specifications of the appliance.	2.9 (6.6)	60	81.6	70.2	3.82	6.0
			80/67	45.1	37.0	60.7	4.84	9.3				70	80.4	68.2	4.22	5.3
			85/71	48.4	38.4	63.9	4.79	10.1				80	79.2	66.2	4.67	4.7
	12	2.9 (6.6)	75/63	42.6	35.8	57.9	4.77	8.9			60	85.8	74.4	3.82	6.0	
			80/67	45.8	37.3	60.9	4.71	9.7			70	84.6	72.4	4.22	5.3	
			85/71	49.2	38.7	64.2	4.65	10.6			80	83.4	70.4	4.67	4.7	
	18	5.9 (13.7)	75/63	43.1	36.0	58.1	4.66	9.2			60	89.4	78.6	3.82	6.0	
			80/67	46.5	37.4	61.3	4.60	10.1			70	88.2	76.6	4.22	5.3	
			85/71	49.9	38.9	64.5	4.53	11.0			80	87.0	74.6	4.67	4.7	



Capacity Data

ES071 – Full Load (2200 CFM)

Cooling									Heating						
Entering Fluid Temp (°F)	Water Flow (GPM)	Pressure Drop PSI (FOH)	Entering Air Temp (db/wb) °F	Total Capacity (MBTUH)	Sensible Capacity (MBTUH)	Heat of Rejection (MBTUH)	Power Input (kW)	EER	Entering Fluid Temp (°F)	Pressure Drop PSI (FOH)	Entering Air Temp (°F)	Total Capacity (MBTUH)	Heat of Absorption (MBTUH)	Power Input (kW)	COP
50	9	2.0 (4.7)	75/63	76.3	56.3	90.2	4.21	18.1	30	2.3 (5.3)	60	52.5	37.5	4.52	3.4
			80/67	81.4	57.9	95.5	4.27	19.1			70	51.8	35.4	4.91	3.1
			85/71	86.6	59.3	101.0	4.34	20.0			80	51.2	33.3	5.33	2.8
	12	8 (3.5)	75/63	77.6	57.0	91.1	4.05	19.2		60	54.0	38.8	4.56	3.5	
			80/67	82.9	58.6	96.5	4.10	20.2		70	53.2	36.7	4.95	3.2	
			85/71	88.3	60.0	102.2	4.16	21.2		80	52.5	34.4	5.36	2.9	
	18	16.5 (7.2)	75/63	79.1	57.6	91.9	3.87	20.4		60	55.8	40.1	4.60	3.6	
			80/67	84.5	59.3	97.5	3.92	21.6		70	54.7	37.9	4.98	3.2	
			85/71	90.1	60.7	103.3	3.97	22.7		80	53.8	35.7	5.40	2.9	
60	9	4.6 (2)	75/63	73.3	55.1	88.2	4.54	16.2	40	2.2 (5.1)	60	59.2	43.7	4.68	3.7
			80/67	78.2	56.6	93.4	4.60	17.0			70	58.6	41.4	5.07	3.4
			85/71	83.3	58.1	98.8	4.67	17.8			80	57.7	39.3	5.48	3.1
	12	7.7 (3.3)	75/63	74.6	55.7	89.1	4.38	17.0		60	61.2	45.4	4.72	3.8	
			80/67	79.7	57.3	94.4	4.43	18.0		70	60.1	43.1	5.11	3.4	
			85/71	85.0	58.8	99.9	4.49	18.9		80	59.3	40.8	5.52	3.1	
	18	16 (6.9)	75/63	76.0	56.3	89.9	4.22	18.0		60	63.5	47.2	4.77	3.9	
			80/67	81.3	58.0	95.4	4.26	19.1		70	62.3	44.6	5.16	3.5	
			85/71	86.7	59.5	101.1	4.31	20.1		80	61.1	42.3	5.57	3.2	
70	9	1.9 (4.4)	75/63	70.2	53.7	86.3	4.90	14.3	50	2.1 (4.9)	60	66.9	50.9	4.84	4.0
			80/67	75.0	55.2	91.4	4.96	15.1			70	65.8	48.5	5.24	3.7
			85/71	79.9	56.8	96.5	5.02	15.9			80	64.8	45.8	5.66	3.4
	12	3.2 (7.4)	75/63	71.5	54.3	87.1	4.74	15.1		60	69.3	53.3	4.90	4.1	
			80/67	76.5	55.8	92.3	4.79	16.0		70	68.2	50.2	5.29	3.8	
			85/71	81.6	57.4	97.6	4.85	16.8		80	67.1	47.6	5.72	3.4	
	18	6.7 (15.4)	75/63	72.8	54.6	88.0	4.62	15.8		60	71.9	55.2	4.95	4.3	
			80/67	77.9	56.4	93.2	4.64	16.8		70	70.5	52.7	5.35	3.9	
			85/71	83.1	58.1	98.7	4.68	17.8		80	69.2	49.8	5.77	3.5	
80	9	1.9 (4.3)	75/63	67.1	52.2	84.4	5.29	12.7	60	2.0 (4.7)	60	75.2	58.2	5.02	4.4
			80/67	71.7	53.9	89.2	5.35	13.4			70	74.0	55.4	5.42	4.0
			85/71	76.4	55.5	94.2	5.41	14.1			80	72.9	52.6	5.86	3.6
	12	3.1 (7.2)	75/63	68.3	52.8	85.1	5.13	13.3		60	78.0	61.4	5.08	4.5	
			80/67	73.0	54.6	90.0	5.18	14.1		70	76.5	58.6	5.49	4.1	
			85/71	77.9	56.2	95.1	5.23	14.9		80	75.3	55.0	5.92	3.7	
	18	6.5 (15)	75/63	69.4	53.3	85.7	4.99	13.9		60	81.2	63.7	5.15	4.6	
			80/67	74.3	55.1	90.9	5.03	14.8		70	79.4	60.6	5.56	4.2	
			85/71	79.5	56.6	96.3	5.07	15.7		80	77.8	57.8	6.00	3.8	
85	9	1.8 (4.2)	75/63	65.4	51.7	83.3	5.50	11.9	70	2.0 (4.6)	60	83.8	66.6	5.21	4.7
			80/67	70.0	53.2	88.2	5.56	12.6			70	82.3	63.7	5.63	4.3
			85/71	74.5	55.0	93.0	5.62	13.3			80	80.8	60.5	6.07	3.9
	12	3.1 (7.1)	75/63	66.7	52.0	84.2	5.35	12.5		60	86.7	69.3	5.28	4.8	
			80/67	71.3	53.8	89.0	5.39	13.2		70	84.9	66.2	5.70	4.4	
			85/71	76.2	55.4	94.1	5.44	14.0		80	83.2	62.9	6.14	4.0	
	18	6.4 (14.7)	75/63	67.6	52.6	84.7	5.20	13.0		60	91.0	72.8	5.37	5.0	
			80/67	72.6	54.4	89.8	5.24	13.9		70	89.0	69.2	5.79	4.5	
			85/71	77.5	56.1	94.9	5.27	14.7		80	87.3	65.9	6.24	4.1	
90	9	1.8 (4.2)	75/63	63.8	50.9	82.5	5.72	11.2	80	1.9 (4.4)	60	92.8	74.9	5.41	5.0
			80/67	68.1	52.7	87.0	5.78	11.8			70	91.1	71.6	5.84	4.6
			85/71	72.8	54.2	92.0	5.85	12.5			80	89.4	68.3	6.30	4.2
	12	3.0 (7)	75/63	64.8	51.5	83.0	5.56	11.7		60	97.0	78.9	5.51	5.2	
			80/67	69.4	53.2	87.8	5.61	12.4		70	94.9	75.4	5.94	4.7	
			85/71	74.1	54.9	92.7	5.66	13.1		80	93.0	71.9	6.40	4.3	
	18	6.3 (14.5)	75/63	65.8	50.5	83.9	5.51	11.9		60	101.3	82.3	5.62	5.3	
			80/67	70.7	53.6	88.6	5.46	12.9		70	98.9	78.2	6.04	4.8	
			85/71	75.7	55.0	93.8	5.51	13.7		80	97.0	74.5	6.51	4.4	
100	9	1.7 (4)	75/63	60.4	49.4	80.6	6.20	9.7	Extended Range - Anti-freeze required	AHRI/ISO13256-1 certified performance is rated at entering air conditions of 80.6°F DB and 66.2°F WB in cooling and 68°F DB in heating. Tabulated unit performance does not include fan or pump power corrections required for AHRI/ISO standard performance ratings. Unit performance may be interpolated. Extrapolation is not allowed. For conditions other than rating conditions provided, consult the BST selection software. Ratings below 40°F are with a methanol solution. The results reported herein are estimates based on testing by FHP. Variations in the installation and operational environment may alter performance. Bosch disclaims all warranties, express and implied, that the performance will be as reported, including the warranty of merchantability and fitness for purpose. In addition, continuous research and development may result in a change to an appliances design and specifications, which Bosch may change without notice. Before purchase, confirm the design specifications of the appliance.	FHP	AHRI CERTIFIED www.ahrincertified.org	ETD US Intertek		
			80/67	64.6	51.2	85.1	6.26	10.3							
			85/71	69.0	52.8	89.7	6.33	10.9							
	12	3.0 (6.8)	75/63	61.4	49.8	81.2	6.05	10.1							
			80/67	65.7	51.8	85.6	6.09	10.8							
			85/71	70.2	53.5	90.3	6.13	11.4							
	18	6.1 (14.1)	75/63	62.2	49.7	81.7	5.97	10.4							
			80/67	66.8	52.2	86.1	5.90	11.3							
			85/71	71.5	54.0	91.1	5.98	12.0							
110	9	1.7 (3.9)	75/63	56.9	48.0	78.8	6.75	8.4							
			80/67	60.9	49.8	83.1	6.81	8.9							
			85/71	65.0	51.5	87.5	6.88	9.4							
	12	2.9 (6.6)	75/63	57.8	48.5	79.3	6.60	8.8							
			80/67	62.0	50.2	83.7	6.64	9.3							
			85/71	66.2	52.1	88.1	6.68	9.9							
	18	5.9 (13.7)	75/63	58.4	48.8	79.5	6.50	9.0							
			80/67	62.8	50.7	84.0	6.47	9.7							
			85/71	67.4	51.6	89.0	6.58	10.2							

Electrical Data

ECM Constant Airflow Motor

Model	Voltage Code	Voltage/Phase/Hz	Voltage Min/Max	Compressor			Total Unit w/ Constant Airflow Motor			Run Capacitor (µF/V)
				Quantity	RLA	LRA	FLA	Min Circuit Amps	Max Fuse/HACR	
ES025	1	208-230/1/60	197/253	1	11.7	58.3	2.8	17.4	25	35/370
	2	265-277/1/60	239/291	1	9.1	54.0	2.6	14.0	20	40/370
ES035	1	208-230/1/60	197/253	1	15.3	83.0	4.3	23.4	35	40/370
	3	208-230/3/60	197/253	1	11.6	73.0	4.3	18.8	30	-
	4	460/3/60	414/506	1	5.7	38.0	4.1	11.2	15	-
ES049	1	208-230/1/60	197/253	1	21.2	104.0	6.8	33.3	50	30/370
	3	208-230/3/60	197/253	1	14.0	83.1	6.8	24.3	35	-
	4	460/3/60	414/506	1	6.4	41.0	5.5	13.5	15	-
ES061	1	208-230/1/60	197/253	1	27.1	152.9	9.1	43.0	70	40/440
	3	208-230/3/60	197/253	1	16.5	110.0	9.1	29.7	45	-
	4	460/3/60	414/506	1	7.2	52.0	6.9	15.9	20	-
ES071	1	208-230/1/60	197/253	1	29.7	179.2	9.1	46.2	70	40/440
	3	208-230/3/60	197/253	1	17.6	136.0	9.1	31.1	45	-
	4	460/3/60	414/506	1	8.5	66.1	6.9	17.5	25	-

NOTES: 1. Resistance value tolerance +/- 7%. All resistance values must be measured with compressor at room temperature.
 2. 460/3/60 units will require a neutral wire for ECM constant airflow fan motor. The motor is 277V single phase.

For units with a factory installed heater kit option, there will be two separate data plates for each electrical circuit. The 1st data plate will be for the compressor power connection, and the 2nd data plate will be for the electric heater, fan motor and UPM board and controls.

Model	Voltage Code	Voltage/Phase/Hz	Voltage Min/Max	Compressor			Min. Circuit Amps	HARC Breaker
				Quantity	RLA	LRA		
ES025	1	208-230/1/60	197/253	1	11.7	58.3	14.6	25
ES035	1	208-230/1/60	197/253	1	15.3	83.0	19.1	30
	3	208-230/3/60	197/253	1	11.7	73.0	14.5	25
ES049	1	208-230/1/60	197/253	1	21.2	104.0	26.5	45
	3	208-230/3/60	197/253	1	14.0	83.1	17.5	30
ES061	1	208-230/1/60	197/253	1	27.1	152.9	33.9	60
	3	208-230/3/60	197/253	1	16.5	110.0	20.6	35
ES071	1	208-230/1/60	197/253	1	29.7	179.2	37.1	60
	3	208-230/3/60	197/253	1	17.6	136.0	22.0	35

NOTES: 208/230V units shipped with transformer wired for 230V—for 208V remove orange transformer primary lead and replace with red lead. All blower motors are single phase.

UNIT POWER SUPPLY: A voltage variation of +/- 10% of nameplate rating is acceptable. Phase imbalance shall not exceed 2%.

2nd Data Plate for Units with Electric Heat Option

ECM Constant Airflow Motor

Model	EH Rated kW	Stage	Heater Watts		Heater AMPS			Circuit	MCA		MOP	
			240	208	240V	208V	Motor FLA (A)	Fuses*	240V	208V	240V	208V
ES025	4.8	1	4,800	3,600	20.0	17.3	2.8	-	28.5	25.1	30	30
ES025	9.6	1	9,600	7,200	40.0	34.6	2.8	-	53.5	46.8	60	50
ES035	4.8	1	4,800	3,600	20.0	17.3	4.3	-	30.4	27.0	35	30
ES035	9.6	1	9,600	7,200	40.0	34.6	4.3	-	55.4	48.6	60	50
ES049	4.8	1	4,800	3,600	20.0	17.3	6.8	-	33.5	30.1	35	35
ES049	9.6	1	9,600	7,200	40.0	34.6	6.8	-	58.5	51.8	60	60
ES049	14.4	2	14400	10800	60.0	51.9	6.8	2 x 30	83.5	73.4	90	80
								2 x 60				
ES061	4.8	1	4,800	3,600	20.0	17.3	9.1	-	36.4	33.0	40	35
ES061	9.6	1	9,600	7,200	40.0	34.6	9.1	-	61.4	54.6	70	60
ES061	14.4	2	14400	10800	60.0	51.9	9.1	2 x 30	86.4	76.3	90	80
								9.1				
ES061	19.2	2	19200	14000	80.0	69.2	9.1	2 x 30	111.4	97.9	125	100
								9.1				
ES071	4.8	1	4,800	3,600	20.0	17.3	9.1	-	36.4	33.0	40	35
ES071	9.6	1	9,600	7,200	40.0	34.6	9.1	-	61.4	54.6	70	60
ES071	14.4	2	14400	10800	60.0	51.9	9.1	2 x 30	86.4	76.3	90	80
								2 x 60				
ES071	19.2	2	19200	14000	80.0	69.2	9.1	2 x 30	111.4	97.9	125	100
								2 x 60				

*10kW UL requirement to include internal fuses for unit.

NOTES: 208/230V units shipped with transformer wired for 230V—for 208V remove orange transformer primary lead and replace with red lead. All blower motors are single phase. **430/3/60 unit has a 277 volt single phase motor and will require one hot, one neutral and a ground wire.**

UNIT POWER SUPPLY: A voltage variation of +/- 10% of nameplate rating is acceptable. Phase imbalance shall not exceed 2%.

Subject to change without prior notice.

Blower Motor Performance

ECM Constant Airflow (Variable Speed)

Model	Available External Static Pressure (in. wc. Wet coil and filter included)													
	Fan Speed	Rated Airflow	Adjust	Tap	0.10	0.20	0.30	0.40	0.50	0.60	0.70	0.80	0.90	1.00
ES025 Part Load	Hi	600	+	A	600	600	600	600	600	600	600	600	-	-
	Med	500	Normal	A	500	500	500	500	500	500	500	500	-	-
	Low	425	-	A	425	425	425	425	425	425	425	425	-	-
ES025 Full Load	Hi	900	+	A	900	900	900	900	900	900	900	900	-	-
	Med	750	Normal	A	750	750	750	750	750	750	750	750	-	-
	Low	650	-	A	650	650	650	650	650	650	650	650	-	-
ES035 Part Load	Hi	1200	+	A	1200	1200	1200	1200	1200	1200	1200	1200	1200	1200
	Med	1050	Normal	A	1050	1050	1050	1050	1050	1050	1050	1050	1050	1050
	Low	900	-	A	900	900	900	900	900	900	900	900	900	900
ES035 Full Load	Hi	1400	+	A	1400	1400	1400	1400	1400	1400	1400	1400	1400	1400
	Med	1225	Normal	A	1225	1225	1225	1225	1225	1225	1225	1225	1225	1225
	Low	1050	-	A	1050	1050	1050	1050	1050	1050	1050	1050	1050	1050
ES049 Part Load	Hi	1100	+	B	1100	1100	1100	1100	1100	1100	1100	1100	1100	1100
	Med	925	Normal	B	925	925	925	925	925	925	925	925	925	925
	Low	800	-	B	800	800	800	800	800	800	800	800	800	800
ES049 Full Load	Hi	1700	+	B	1700	1700	1700	1700	1700	1700	1700	1700	1700	1700
	Med	1500	Normal	B	1500	1500	1500	1500	1500	1500	1500	1500	1500	1500
	Low	1275	-	B	1275	1275	1275	1275	1275	1275	1275	1275	1275	1275
ES061 Part Load	Hi	1725	+	A	1725	1725	1725	1725	1725	1725	1725	1725	1725	1725
	Med	1500	Normal	A	1500	1500	1500	1500	1500	1500	1500	1500	1500	1500
	Low	1275	-	A	1275	1275	1275	1275	1275	1275	1275	1275	1275	1275
ES061 Full Load	Hi	2300	+	A	2300	2300	2300	2300	2300	2300	2300	2300	2300	2300
	Med	2000	Normal	A	2000	2000	2000	2000	2000	2000	2000	2000	2000	2000
	Low	1700	-	A	1700	1700	1700	1700	1700	1700	1700	1700	1700	1700
ES071 Part Load	Hi	1850	+	A	1850	1850	1850	1850	1850	1850	1850	1850	1850	1850
	Med	1600	Normal	A	1600	1600	1600	1600	1600	1600	1600	1600	1600	1600
	Low	1500	-	A	1525	1525	1525	1525	1525	1525	1525	1525	1525	1525
ES071 Full Load	Hi	2300	+	A	2300	2300	2300	2300	2300	2300	2300	2300	2300	2300
	Med	2200	Normal	A	2250	2250	2250	2250	2250	2250	2250	2250	2250	2250
	Low	1900	-	A	1900	1900	1900	1900	1900	1900	1900	1900	1900	1900

NOTES: 1. Airflow is 70% of tabulated values during fan only operation. Air flow is 85% of tabulated value during passive dehumidification mode when enabled.

2. Units are built with "Nominal" airflow as the default setting and can be field adjusted to produce the plus or minus airflow; see OEM for details

Subject to change without prior notice.

Physical Data

ES Model Water Source Heat Pump

ES Model	ES025	ES035	ES049	ES061	ES071
Compressor Type (Qty 1)	Scroll	Scroll	Scroll	Scroll	Scroll
Refrigeration Charge (oz)	68	68	78	90	111
Max Water Working Pressure (PSIG/kPa)	450/3100	450/3100	450/3100	450/3100	450/3100
ECM Constant CFM					
Fan Motor Type/Speeds	ECM Const Air Flow	ECM Const Air Flow	ECM Const Air Flow	ECM Const Air Flow	ECM Const Air Flow
Fan Motor (HP)	1/3	1/2	3/4	1	1
Blower Wheel Size (Dia. x W)	9x7	9x7	10x8	11x9	11x9
Water Connection Size					
FPT	3/4"	3/4"	1"	1"	1"
Coaxial Coil Volume (gal)	0.49	0.49	0.64	0.77	1.05
Vertical Cabinet					
Air Coil Dimensions (H x W), in	24 X 21	24 X 21	24 X 27	24 X 27	32 X 27
Nominal size of Standard Filter - 1" MERV 5 (L x H)	24 X 24	24 X 24	24 X 30	24 X 30	16 X 30 (2)
Weight - Operating (lbs)	290	290	318	390	450
Weight - Shipping (lbs)	315	315	348	415	495
Horizontal Cabinet					
Air Coil Dimensions (H x W), in	18 X 28	18 X 28	20 X 32.5	20 X 32.5	20 X 43
Nominal size of Standard Filter - 1" MERV 5 (L x H)	20 X 30	20 X 30	20 X 34.5	20 X 34.5	20 X 24 (2)
Weight - Operating (lbs)	290	290	318	390	450
Weight - Shipping (lbs)	315	315	348	415	495

Horizontal Cabinet Corner Weights

Configuration			Left Hand Evaporator				Right Hand Evaporator			
Model		Total	Left Front*	Right Front*	Left Back	Right Back	Left Front*	Right Front*	Left Back	Right Back
ES025	lbs	290	72	102	58	58	72	102	58	58
	kg	132	33	46	26	26	33	46	26	26
ES035	lbs	290	72	102	58	58	72	102	58	58
	kg	132	33	47	26	26	33	47	26	26
ES049	lbs	318	79	111	64	64	79	111	64	64
	kg	145	36	51	29	29	36	51	29	29
ES061	lbs	390	97	137	78	78	97	137	78	78
	kg	177	44	62	35	35	44	62	35	35
ES071	lbs	450	112	158	90	90	112	158	90	90
	kg	205	51	72	41	41	51	72	41	41

* Front is control box end.

Vertical Unit Dimensions

ES Model Water Source Heat Pump

Model	A	B	C	D	E	F	G	H	J	K	M	N	P	Q	Condenser Water Connections	Recommended Replacement Nominal Filter Size
	Width	Depth	Height	Discharge Depth	Discharge Width	Cabinet Edge to Discharge	Left Side to Discharge	Water In	Bottom to Condensate Drain	Water Out	R/A Duct Width	R/A Duct Flange Height	Filter Rack Height	Right Side to Discharge		
ES025	21.50	26.00	47.25	13.75	15.75	6.13	5.25	2.50	8.00	13.50	22.00	22.00	24.00	4.00	3/4" FPT	24 X 24
ES035	21.50	26.00	47.25	13.75	15.75	6.13	5.25	2.50	8.00	13.50	22.00	22.00	24.00	4.00	3/4" FPT	24 X 24
ES049	24.00	32.75	47.25	15.75	15.75	8.38	5.50	2.50	8.00	14.75	28.50	22.00	24.00	4.00	1" FPT	24 X 30
ES061	26.00	33.25	51.25	17.75	17.75	7.13	6.25	2.50	8.00	14.75	28.50	22.00	24.00	4.00	1" FPT	24 X 30
ES071	26.00	33.25	58.25	17.75	17.75	8.00	7.75	2.50	8.00	14.75	28.50	30.00	32.00	1.50	1" FPT	16 X 30 (2)

NOTES: 1. All dimensions in inches unless otherwise noted. All dimensions within +0.125". Specifications subject to change without notice.
 2. For each configuration, add relevant dimensional information and drawings for units with Waterside Economizer

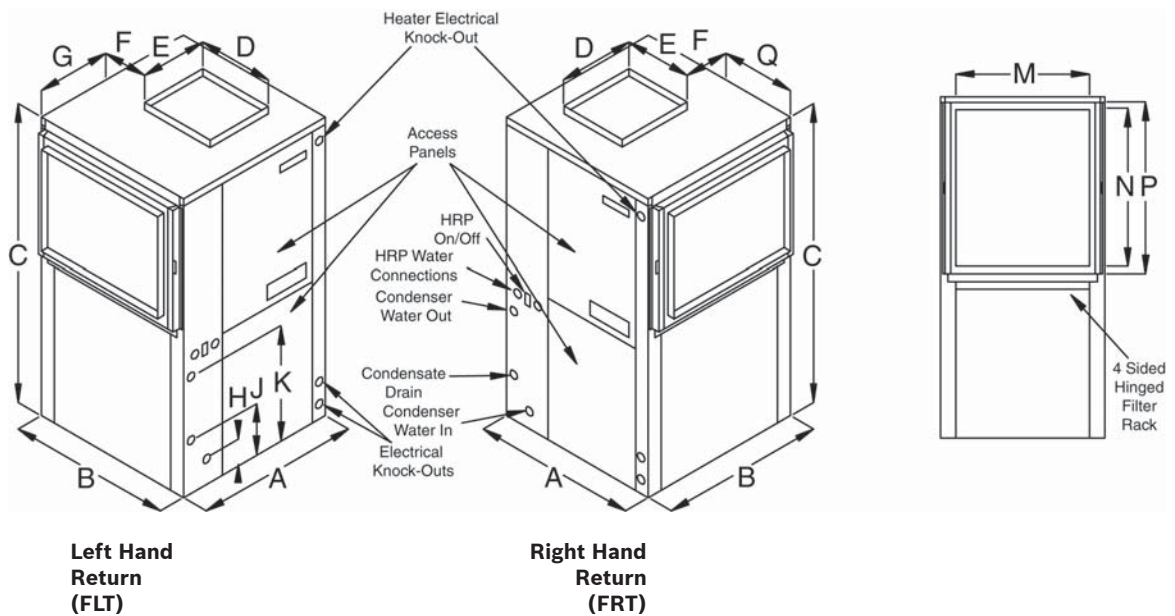

Figure 12

Horizontal Unit Dimensions

ES Model Water Source Heat Pump

Model	A	B	C	D	E	F	G	H	J	K	M	N	P	Q	R	T	Condenser Water Connections	Recommended Replacement Nominal Filter Size
	Width	Depth	Height	Cab End to Filter Rack	R/A Duct Width	Cab Front to Filter Rack	Water In	Water Out	Side to Discharge	Discharge Width	Top to Discharge (FLE & FRS)	Discharge Height	End to Discharge	Top to Discharge (FRE & FLS)	Filter Rack Height	R/A Duct Flange Height		
ES025	26.00	54.50	21.75	2.00	30.00	22.50	2.50	13.50	4.50	13.75	3.00	15.75	4.50	3.00	20.00	18.00	3/4" FPT	20X30
ES035	26.00	54.50	21.75	2.00	30.00	22.50	2.50	13.50	4.50	13.75	3.00	15.75	4.50	3.00	20.00	18.00	3/4" FPT	20X30
ES049	30.00	68.00	21.75	2.50	33.50	32.00	2.50	14.50	5.81	15.75	3.00	15.75	5.81	2.00	20.00	18.00	1" FPT	20X34.5
ES061	30.00	68.00	21.75	2.50	33.50	32.00	2.50	14.50	7.66	17.75	2.00	17.75	7.66	2.00	20.00	18.00	1" FPT	20X34.5
ES071	30.00	78.00	21.75	2.50	44.00	31.50	2.50	14.50	3.50	17.75	2.75	17.75	7.66	1.00	20.00	18.00	1" FPT	20X24 (2)

NOTE: All dimensions in inches unless otherwise noted. All dimensions within +0.125". Specifications subject to change without notice.

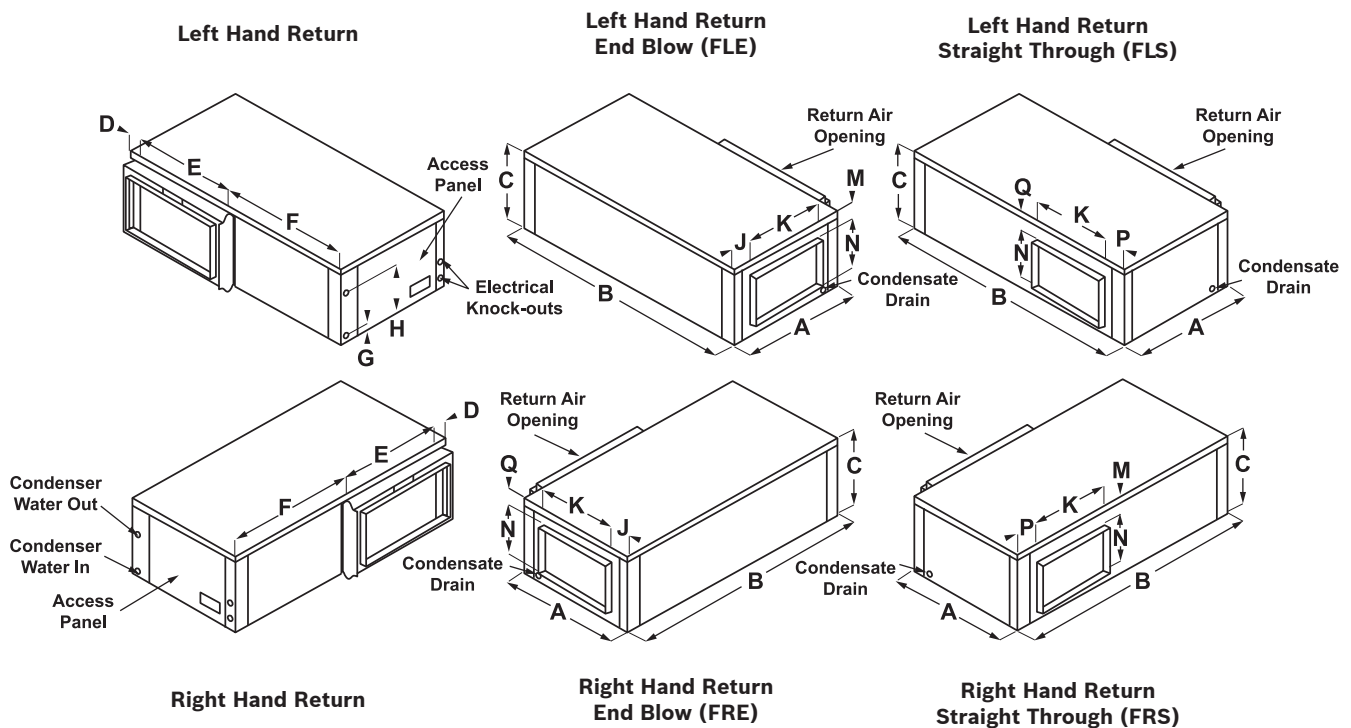

Figure 13

Counterflow Unit Dimensions

ES Model Water Source Heat Pump

Model	A	B	C	D	E	F	G	H	J	K	M	N	P	Condenser Water Connections	Recommended Replacement Nominal Filter Size
	Width	Depth	Height	Discharge Depth	Discharge Width	Cabinet Edge to Discharge	Left Side to Discharge	Water Out	Water In	Right Side to Discharge	R/A Duct Width	R/A Duct Flange height	Filter Rack Height		
ES025	21.50	26.00	47.25	9.25	10.25	6.00	5.50	8.50	19.50	9.75	22.00	22.00	24.00	3/4" FPT	24X24
ES035	21.50	26.00	47.25	9.25	10.25	6.00	5.50	8.50	19.50	9.75	22.00	22.00	24.00	3/4" FPT	24X24
ES049	24.00	32.75	47.25	10.75	11.50	11.13	6.88	7.50	18.50	8.75	28.00	22.00	24.00	1" FPT	24X30
ES061	26.00	33.25	51.25	12.00	12.50	8.38	5.00	9.75	21.75	10.50	28.00	22.00	24.00	1" FPT	24X30
ES071	26.00	33.25	58.25	12.75	13.50	9.75	4.50	7.00	20.25	11.00	28.00	30.00	32.00	1" FPT	16X30(2)

NOTE: All dimensions in inches unless otherwise noted. All dimensions within +0.125". Specifications subject to change without notice.

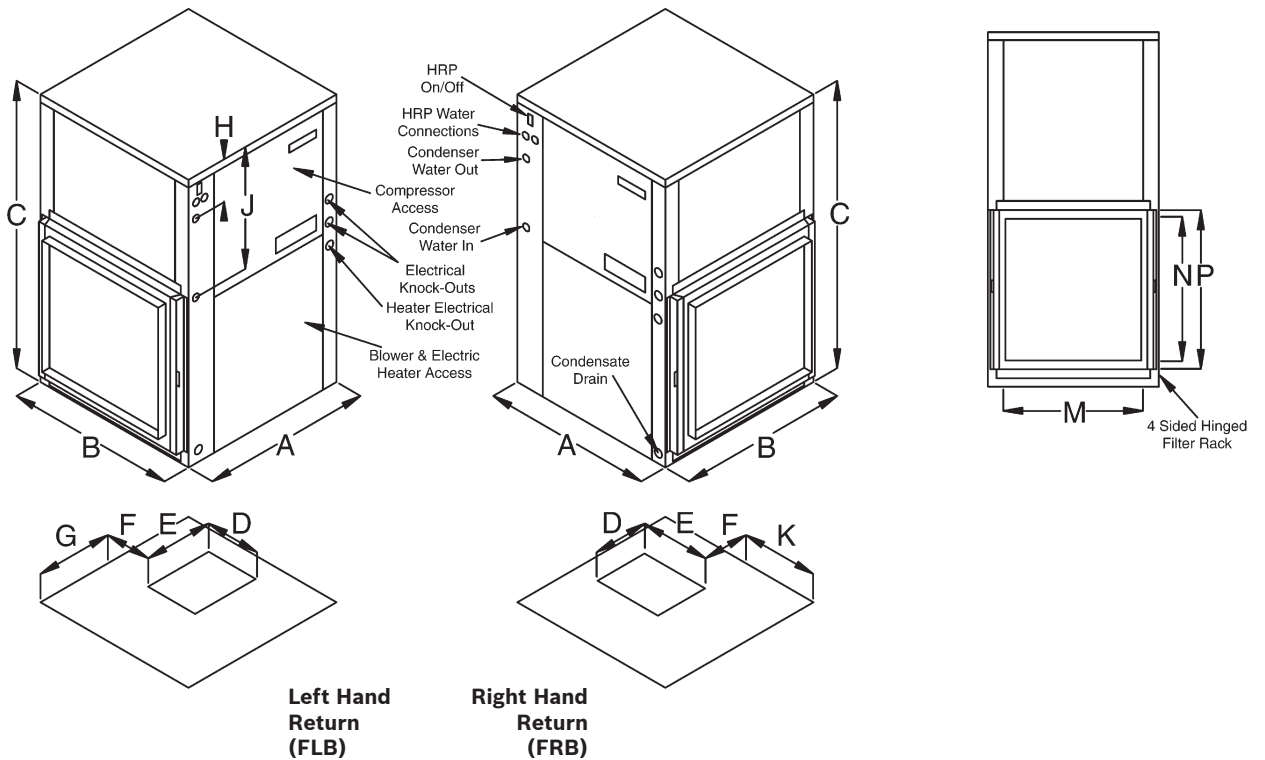

Figure 14

Guide Specifications

General

Furnish and install FHP water source heat pumps as indicated on the plans with capacities and characteristics as listed in the schedule with the specifications that follow. The units shall be manufactured in an ISO 9001:2000 certified facility.

Equivalent units from other manufacturers can be proposed provided approval to bid is given 10 days prior to bid closing.

Horizontal, Vertical & Counterflow Water Source Heat Pumps

Units shall be designed to operate throughout the range of entering fluid temperature of 50°F to 110°F in the cooling mode and 30°F to 80°F in the heating mode (extended range allows for 20°F to 80°F in the heating mode). All equipment shall be lower than a nominal capacity of 135,000 BTU/h of Total Cooling (TC) listed in the current ARI Applied Equipment Directory under the ARI Standard ARI ISO-13256-1, WLHP, GWHP, and GLHP Rating.

All equipment in this section must meet or exceed the national standard minimum Energy Efficiency Ratio (EER) and Coefficient of Performance (COP) as listed in ASHRAE 90.1 per the following:

ARI-ISO-13256-1, WLHP Rating (13.0 EER and 4.3 COP for units with a nominal cooling capacity of

17,000 BTU/h or larger – 12.2 EER and 4.3 COP for units with a nominal cooling capacity lower than 17,000 BTU/h).

For the ARI-ISO-13256-1, GLHP Rating a minimum 13.4 EER and 3.1 COP.

All units shall be listed with Intertek (ETL), Nationally Recognized Testing Laboratories (NRTL) or Canadian Standards Association (CSA). All units shall have ARI-13256-1 labels with ETL or NRTL or CSA or equivalent labels.

Standard Construction

Units shall have the air flow arrangement as shown on the plans. If units with these arrangements are not used, the contractor supplying the water source heat pumps is responsible for any extra costs incurred by other trades. Contractor must submit detailed mechanical drawings showing ductwork requirements and changes

or relocation of any other mechanical or electrical system. If other arrangements make servicing difficult the contractor must provide access panels and clear routes to ease service. **The architect must approve all changes 10 days prior to bid.**

All units shall have stainless steel drain pans to comply with this project's Indoor Air Quality (IAQ) requirements. No exceptions will be allowed.

All water source heat pumps shall be fabricated from galvanized sheet metal for corrosion protection.

All interior surfaces are lined with ½" thick, 1.5lb./cubic foot dual density Micromat insulation for thermal insulation and acoustical attenuation (½" thick closed cell foam insulation is optional). Insulation must be non-combustible, non-hygroscopic and anti-fungal. Insulation must meet NFPA 90A and 90B for fire protection, UL181 erosion requirements, and be certified to meet GREENGUARD™ indoor air quality (IAQ) standards for low emitting products.

One blower access panel and two compressor compartment access panels shall be removable with supply and return air ductwork in place.

Unit shall be equipped with double compressor isolation. The unit shall have a floating base pan consisting of the compressor mounted on rubber grommets and a heavy gauge steel plate supported by a ½" (12 mm) thick, high density rubber pad on the base of the unit to prevent transmission of vibration to the structure.

All units shall have a factory installed four sided filter rack with access panel, capable of accepting either one or two inch filters. Units shall have a 1 inch thick, MERV-5 throwaway type glass fiber filter as standard. The filter rack shall incorporate a 1 inch duct flange. The contractor shall purchase one spare set of filters and replace the factory shipped construction filter upon completion of start-up.

High Efficiency Filtration – Units shall include MERV-8 or MERV-13 air filters. (optional)

Cabinets shall have separate knockouts for entrance of line voltage and low voltage control wiring.

Supply and return water connections shall be brass FPT fittings and shall be securely mounted flush to the cabinet allowing for connection to a flexible hose without the use of a back-up wrench. Water connections which protrude through the cabinet shall not be allowed.

Guide Specifications

Hanging brackets shall be provided as standard for horizontal units.

Condensate overflow protection sensor shall activate a circuit upon sensing when a high level of condensate water is in the drain pan resulting in a hard lockout in the unit.

Freeze protection sensors shall be provided on both sides of the refrigeration circuit. Sensors that measure water temperature shall not be allowed. (Refer to Solid State Safety Circuit section in this spec guide).

Fan Motor & Assembly

The blower housing shall feature a removable inlet ring to facilitate removal and servicing of the direct-drive centrifugal fan. The fan motor shall be isolated from the fan housing by torsionally flexible isolation.

The fan shall be direct drive centrifugal forward curved type with a dynamically balanced wheel. The housing and wheel shall be designed for quiet low velocity operation. The fan housing shall be removable from the unit without disconnecting the supply air ductwork for servicing of the fan motor. The fan motor shall be a Constant CFM (airflow) ECM microprocessor controlled DC type motor with internal programming factory set for the specific unit and featuring soft start/stop and a delay off feature for maximum efficiency and quiet operation. Air flow rates shall be varied according to the staging of the unit. There will further be provisions for adjusting the air delivery of the motor and blower by +/- 15% from rated air flow.

The 460V-3PHz-60Hz units with these motors must be able to operate without the need for a neutral wire for the motor.

The fan and motor assembly must be capable of overcoming the external static pressures (ESP) as shown on the schedule. ESP rating of the unit shall be based on a wet coil. Ratings based on a dry coil will NOT be acceptable.

Refrigerant Circuit Components

Units shall use R-410A refrigerant. All units shall have a factory sealed and fully charged refrigerant circuit.

All units shall contain a sealed refrigerant circuit including a hermetic two stage scroll compressor, bidirectional thermal expansion valve metering device, finned tube

air-to-refrigerant heat exchanger, refrigerant reversing valve and service ports. Compressor shall be high efficiency scroll type, designed for heat pump duty, quiet operation and mounted on rubber vibration isolators. Compressor motors shall be equipped with overload protection. Refrigerant reversing valves shall be pilot operated sliding piston type with replaceable encapsulated magnetic coils energized only during the cooling cycle. The finned tube coil shall be constructed of lanced aluminum fins not exceeding fourteen fins per inch bonded to rifled copper tubes in a staggered pattern not less than three rows deep and have a 600 PSIG (4140 kPa) working pressure. Coils shall be uncoated standard with an optional tin plating on the copper tubing for protection against common forms of chemical and salt corrosion. Coil end plates shall be aluminum. The coaxial water-to-refrigerant heat exchanger shall be constructed of a convoluted copper (optional cupro-nickel) inner tube and steel outer tube with a designed refrigerant working pressure of 600 PSIG (4140 kPa) and a designed water side working pressure of no less than 450 PSIG (3100 kPa). The water-to-refrigerant heat exchanger shall be insulated to prevent condensation at low fluid temperatures.

Coaxial refrigerant to water heat exchanger shall be insulated to allow for geothermal applications.

Refrigerant safety controls shall include both high and low pressure safety switches. Temperature sensors shall not replace these safety switches.

Access fittings (Schrader Valves) shall be factory installed on high and low pressure refrigerant lines to facilitate field service.

Electrical

A control box shall be located within the unit and shall contain a transformer, controls for the compressor, reversing valve and fan motor and shall have a terminal block for low voltage field wiring connections. The transformer shall be rated for a minimum 75VA. All units shall be name-plated for use with time delay fuses or Heating, Air Conditioning & Refrigeration (HACR) circuit breakers.

Control transformer shall be rated for minimum 100VA. (optional)

Unit controls shall be 24 volts.

Guide Specifications

All transformers shall have a push button reset circuit breaker on the secondary power.

Solid State Safety Circuit

All units shall have a solid-state Unit Protection Module (UPM) safety control circuit with the following features.

Anti-short cycle time delay on compressor operation (5 min. delay on break).

Random start on power up mode.

Brown out/surge/power interruption protection. Low Pressure Switch 120 second bypass timer. High refrigerant pressure shutdown.

Low refrigerant pressure shutdown.

Low water temperature shutdown. Freeze sensors shall monitor refrigerant temperature to the water coil in the heating mode and shall activate the lockout circuit when water temperature drops below either 15°F or 30°F depending on the selection.

15°F is field selectable for installations utilizing antifreeze; see IOM for details.

Air coil freeze protection shutdown refrigerant coil in the cooling mode.

Condensate overflow protection: A condensate sensor shall activate the lockout circuit upon sensing a high level of condensate in the drain pan and immediately put the unit into a hard lockout. COP shall be standard on all units.

Alarm output which closes for either dry contact closure or 24 VAC remote fault indication. Alarm output is selectable for constant output for general alarm notification, or pulse output for annunciation of the specific fault alarm. Selectable reset of unit at thermostat or disconnect.

Activation of any safety device shall prevent compressor operation via a lockout circuit. The lockout circuit shall be reset at the thermostat or at the contractor supplied disconnect switch. Units which may be reset at the disconnect switch only shall not be acceptable.

Automatic intelligent reset. Unit shall automatically reset after a safety shut down and restart the unit after the anti-short cycle timer and random start timer expire. Should subsequent faults re-occur within 60 minutes after reset, then a permanent lockout will occur. Reset attempts

shall be selectable for either 2 or 4 tries. A condensate overflow will place the unit in an immediate hard lockout.

Ability to defeat time delays for servicing (reduces all time delays to 5 seconds for diagnostic work).

A light emitting diode (LED) to indicate safety alarms. The LED shall annunciate the following alarms:

High refrigerant pressure. Low refrigerant pressure.

Low refrigerant temperature to the water coil in the heating operation

Low refrigerant temperature to the air coil in cooling operation.

High level of condensate in the drain pan.

Brown out/surge/ power interruption.

The LED will display each fault condition as soon as the fault occurs. If a permanent lockout occurs, then the fault will be transmitted to the alarm circuit output terminals until the unit is reset. ETL listed, and RFI, ESD, and transient protected.

Safety devices include:

Low pressure cutout set at 40 PSIG (280 kPa) for loss of charge protection (freezestat and/or high discharge gas temperature sensor is not acceptable).

High pressure cutout control set at 600 PSIG (4125 kPa).

Low supply water temperature sensor protection which monitors refrigerant temperature that could result in water heat exchanger freezing.

Low air coil temperature sensor protection which monitors refrigerant temperature that could result in air heat exchanger freezing.

High level of condensate sensor that shuts off the compressor if the condensate drain pan fills with water.

On board voltage detection that disables the compressor control circuit if there are extreme variations exceeding +/- 10% in supply voltage.

Factory Installed Options

Extra quiet sound package: shall be provided with a compressor blanket and shall have ½" thick closed-cell foam insulation.

Guide Specifications

Closed cell foam: All units have available a ½" thick closed-cell foam insulation.

MERV Filtration: All units shall have a factory installed four sided filter rack with access panel and either 2" MERV-8 filter or MERV-13 pleated filter.

Evaporator Coil Tin-Plated: refrigerant to air coils shall have Tin-plated coating for enhanced protection against formicary and other forms of corrosion on copper tubing.

Cupro-Nickel Water Coil: the refrigerant to water heat exchanger shall be of cupro-nickel inner water tube construction.

All transformers shall be rated 100VA and shall have a push button reset circuit on the secondary power.

Hot Gas Reheat: Units as noted on the schedule shall be equipped with optional Hot Gas Reheat (HGRH). HGRH shall be either on/off control or modulating as noted in the specifications.

On/Off HGRH shall be controlled by a humidistat connected to the unit H terminal and shall start the unit in the reheat mode should the humidity be above setpoint once the thermostat control is satisfied. Cooling or heating requirements shall take precedent over HGRH.

Modulating Hot Gas Reheat (MHGRH) shall be active at all times. A 0 - 10 VDC signal from a sensor located in the unit discharge air supply shall modulate the hot gas valve to maintain an adjustable preset leaving air temperature to the conditioned space.

Passive Dehumidification can be achieved with the Constant Airflow ECM by reducing nominal airflow by 15%. This control feature lowers air coil temperature and prevents over-cooling of the space when in dehumidification mode.

Hot Gas Bypass: For units as noted on the schedule, supply each unit with a ETL listed and MEA listed modulating hot gas bypass valve with factory supplied and installed controls to prevent air coils from frost development by taking hot gas and bypassing the water coil and expansion device and reintroducing the hot gas into the refrigerant line prior to the air coil. The hot gas bypass valve shall maintain a minimum refrigerant suction pressure to allow for a light load cooling mode or a low entering air temperature.

Water Side Economizer: Water side economizer shall be completely installed at the factory, with an additional condensate drain pan, motorized 3 way valve, aqua stat, and all internal electric controls. Water side economizer shall be rated at 400 PSI and UL listed for application with the heat pump. This option is externally mounted outside the unit.

Water Flow Regulator (Automatic Flow Control Valves): Units shall have internal automatic flow control valves set to 3.0 GPM for nominal to of refrigeration capacity.

Two-Position Water Valve: Units shall have internally piped and wired 2-position water solenoid valve to close off flow if unit cycles off.

Heat Recovery Package: 208/230V-1Ph-60Hz and 208/230V-3Ph-60Hz units shall be equipped with factory installed internal heat recovery kit for domestic hot water production. This kit shall include an internally protected hot water circulation pump, copper double wall vented coaxial water-to- refrigerant heat exchanger, 140°F (60°C) hot water temperature limit switch and an on/off switch/ circuit breaker.

Flow Proving Switch: prevents unit operation if there is no fluid flow. This factory installed, internally mounted device shall be rated at 600 psi and disable the compressor if a lack of water- flow occurs.

DDC Controls: Unit shall be equipped with a factory installed DDC control capable of interfacing with BACnet™, Modbus, N2 or Lon works® (with optional card).

The controller shall be preprogrammed to control the unit and monitor the safety controls.

The unit shall be able to operate as a standalone or be integrated into the building management system.

A leaving water and leaving air sensor shall be installed in the unit.

Wall sensors shall be available for controlling zone temperature.

Unit mounted disconnect: A non fused factory mounted disconnect shall be installed on the unit.

Guide Specifications

Internal Electric Heat 208/230-1-60 and 208/230-3-60 volt units shall be equipped with optional factory installed internal electric resistance heat for auxiliary and emergency heat. Electric heater must be Intertek (ETL) approved for safety when installed in the unit. External heater packages or heater packages not specifically listed for use with the unit are unacceptable. Electric heater packages shall include a heater collar mounted to the blower outlet, individual thermal overload protected heater elements no greater than 5kW each and magnetic contactors. Heater packages shall have a separate power supply connection from the compressor and this power supply shall also power the unit blower motor and control transformer for safe operation.

Relays shall be factory installed in the unit as follows:

EMS: Relay for remote enabling of the unit.

Auxiliary pump/valve relay to enable a pump/valve operation when calling for compressor operation.

Compressor monitoring relay – provides a contact closure whenever the compressor contactor is energized.

Blower monitoring relay – provides a contact closure whenever the blower motor is energized.

Boilerless control shall activate an electric heater (internal or external unit) and disable compressor should water temperature drop below set point.

Includes a relay and splitting the power supply to the unit into a blower motor and control power supply and a compressor power supply. The relay (when energized) deactivates the compressor control circuit.

Wire transformer for 208V operation. (available for voltage -1 & -3)

Phase loss and reversal protection shall be provided on the unit to protect the compressor from operating in reverse rotation on three phase units. (available for voltages -3 & -4)

A comfort alert module shall be installed in the unit to assist in service diagnostics (available for voltage -1)

Field Installed Options

All units shall be connected by hoses and have a maximum working pressure 400 PSI for sizes ½" – 1" and 300 PSI for sizes 1 ¼ – 2".

A variety of hose kits are available depending on the job requirement. Kits 2 through 6 include supply and return ported ball shut-off valves with P/T ports. Hose kit options are available in the accessories section of the BST selection software.

Kit 1 – Hose kit either 24" or 36" long.

Kit 2 – Hose kit with ball valves on the supply and return hoses. Valves shall have P/T ports to facilitate pressure and temperature readings.

Kit 3 – Hose kit with automatic flow control valve. The design flow rate is preset at the factory per the specified design conditions and shall automatically limit the flow to this value. This shall facilitate balancing of the fluid loop and allow each unit the required flow.

Kit 4 – Hose kit with an automatic flow control valve and a Y-strainer and blow down valve on the supply side. The filter screen is 20 mesh, 304 stainless steel. This shall prevent dirt and debris from entering the water coil.

Kit 5 – Hose kit with an automatic flow control valve and a 24V, 2-position solenoid valve on the return. This shall be used to shut off flow to the unit when there is not a call for heating or cooling. (Typically used with a VFD pumping.)

Kit 6 – Hose kit with an automatic flow control valve, Y-strainer/BD valve on the return. 24V, automatic flow valve, blow down valve and two position solenoid valve.

Thermostats

The unit control may utilize a multi-stage thermostat or the unit may have a DDC controller integrated into the building management system. All external low voltage control wiring is made to the thermostat terminal located in the unit electrical box. Thermostats may be manual change over, auto change over, programmable or non-programmable depending on the requirements of the project. A full line of thermostats are available for FHP products as an accessory.

Bosch Thermotechnology Corp.

555 NW 65th Court, Fort Lauderdale, FL 33309
Phone: 866-642-3198 | Fax: 954-776-5529
www.boschheatingandcooling.com

Printed on Elemental Chlorine Free, FSC-certified,
minimum 10% PCW paper with vegetable-based inks.
Scan QR code to the right to access product information.

BTC 760904301 B | 03.2016

Copyright © 2014 Bosch Thermotechnology Corp.
All rights reserved. Subject to change without notice.

