

3-WIRE MINI-SPLIT CONDENSATE PUMPS

These quiet & reliable piston style pumps are designed to remove condensate water in mini-split systems up to 42,000 BTUs. The pump includes a NO/NC safety switch to shut the system down in the event of condensate overflow.

These 2-piece compact size pumps include a waterproof pump module & detection module for easy installation.

Features / Benefits

- Removes condensate for systems up to 42,000 BTUs
- 24 foot maximum lift
- Vertical Suction: 6 foot maximum
- USA & Canada Agency Affiliations: ETL Listed 4000786 / CSA Certified C22.2 NO. 108 / Conforms To UL STD 778
- Noise Level: <21dB @ 3.3' distance
- Thermally protected
- Alarm level to prevent overflow
- Waterproof connections prevent water ingress
- Piston pump provides long life
- Optional Mounting Kit: # GC1KFX2010
- 2-year warranty



PART NO.	DESCRIPTION
DE05LUB100	Flowatch® 2 Condensate Pump (115V)
DE05LUB110	Flowatch® 2 Condensate Pump (230V)

Specifications

Voltages:	115 / 230 VAC Single Phase
Hertz:	50/60
Watts:	19
Rating:	70% duty cycle (example 7 seconds on / 3 seconds off)
Safety switch contacts:	5 amp maximum resistive @ 250 VAC
Safety switch wiring:	3-wire = Orange (Common) / Purple (Normally Open) / Grey (Normally Closed)
Working temperature:	41°F to 113°F (5°C to 45°C)
Storage temperature:	37°F to 158°F (3°C to 70°C)

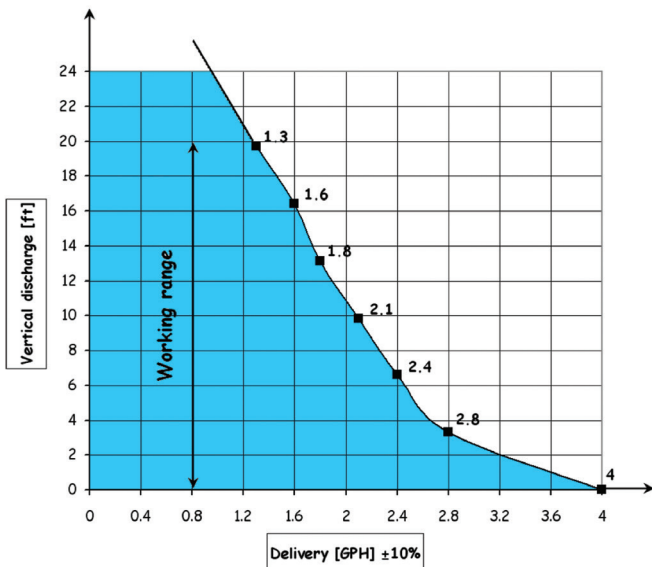

Safety Switch and Main Wiring

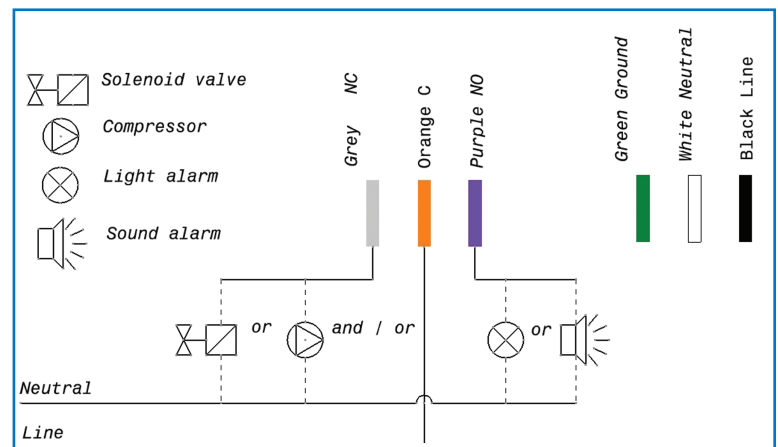



3-WIRE FLOWATCH® Design

3-Wire Mini-Split Condensate Pump with plastic duct & installation kit

- Includes mini FLOWATCH® 2 Pump
- Includes over 2 ½ feet of plastic duct
- Includes all mounting hardware
- Pre-mounted and wired in plastic duct
- 2 year warranty

PART NO.	DESCRIPTION
DE05LUB120	Flowatch® Design Pump & Installation Kit (115V)
DE05LUB130	Flowatch® Design Pump & Installation Kit (230V)

