

Class 3000 & 6000 Threaded

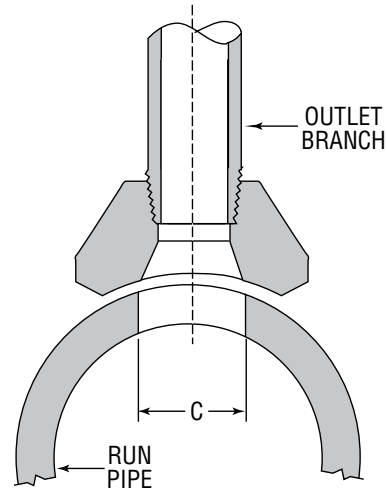

THREADED Class 3000

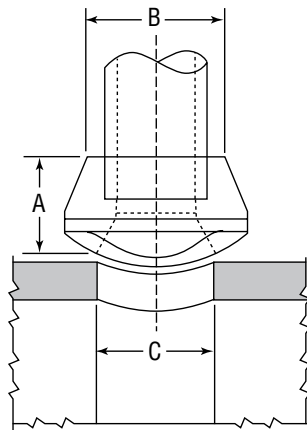

Outlet Size		Dimensions						Unit Weight	
		A		B		C			
NPS	DN	in	mm	in	mm	in	mm	lbs	kg
1/8	6	3/4	19	1	25	0.625	16	0.10	0.05
1/4	8	3/4	19	1 1/16	27	0.437	11	0.14	0.06
3/8	10	13/16	21	1 1/16	27	0.578	15	0.14	0.06
1/2	15	1	25	1 15/32	37	0.718	18	0.28	0.13
3/4	20	1 1/16	27	1 45/64	43	0.922	23	0.39	0.18
1	25	1 1/16	33	2 3/32	53	1.156	29	0.73	0.33
1 1/4	32	1 5/16	33	2 17/32	64	1.500	38	0.96	0.44
1 1/2	40	1 3/8	35	2 25/32	71	1.734	44	1.12	0.51
2	50	1 1/2	38	3 5/16	84	2.218	56	1.66	0.75
2 1/2	65	1 13/16	46	3 29/32	99	2.625	67	2.73	1.24
3	80	2	51	4 21/32	118	3.250	83	3.88	1.76
4	100	2 1/4	57	5 13/16	148	4.250	108	6.18	2.80

THREADED Class 6000

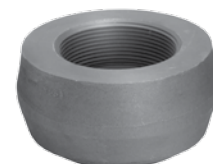

Outlet Size		Dimensions						Unit Weight	
		A		B		C			
NPS	DN	in	mm	in	mm	in	mm	lbs	kg
1/2	15	1 1/4	32	1 3/4	44	0.718	19	0.28	0.13
3/4	20	1 7/16	37	2 1/16	52	0.922	24	0.39	0.18
1	25	1 1/16	40	2 17/32	64	1.156	31	0.73	0.33
1 1/4	32	1 5/8	41	2 1/2	64	1.500	40	0.96	0.44
1 1/2	40	1 11/16	43	3 5/16	84	1.734	46	1.12	0.51
2	50	2 1/16	52	3 31/32	101	2.218	59	1.66	0.75

Each outlet size listed is available to fit any run curvature. Threaded ends are in accordance with ANSI/ASME B1.20.1. Design per MSS-SP-97.

RUN PIPE SIZES Outlet sizes noted above fit a number of run pipe sizes, and the fittings are marked accordingly. See page 3 for run pipe size combination table(s).

FLATS A flat Threaded Universal Forged Steel Anvillet for use on welding caps, elliptical heads and flat surfaces is available.

The A, B and C dimensions given for the Branch Connections in the above Table are for reference only and to be used as a guideline. Dimensions B and C are subject to change depending upon the manufacturing process utilized. Although every attempt has been made to insure that the information contained in this table is correct, Anvil reserves the right to change the C dimension as deemed necessary.

PROJECT INFORMATION		APPROVAL STAMP	
Project:		<input type="checkbox"/> Approved	
Address:		<input type="checkbox"/> Approved as noted	
Contractor:		<input type="checkbox"/> Not approved	
Engineer:		Remarks:	
Submittal Date:			
Notes 1:			
Notes 2:			

Anvil **Anvilets** provide a strong branch pipe connection, considerably stronger than a welded pipe-to-pipe connection. Consequently, with good welding procedures, Anvil **Anvilets** offer greater resistance to distortion and bursting.

Anvil **Anvilets** readily and economically permit the adding of branch connectors to existing piping installations, eliminating the relatively higher cost of cutting or disassembly and re-assembly required for the installation of tees.

Anvil **Anvilets** of the same outlet size as a header or run pipe size (i.e. "Full Size" **Anvilets**) are so proportioned that the (ellipticallyshaped) hole in the header pipe has the minimum weakening or distortion effect, and yet provides good fluid flow characteristics.

Specifications

Chemical and physical properties are rigidly controlled to ensure consistently high quality. Physical and chemical test reports are available on request. Traceability of individual Anvilets can be established through the heat code of each fitting.

Anvil **Anvilets** meet the requirements of MSS standard SP-97. They are forged from steel which complies with ASTM A105.

Threaded Anvilets - conform with ASME B1.20.1.

Socket-Weld Anvilets - dimensions conform with ASME B16.11.

Buttweld Anvilets - ends conform with ASME B16.25.

Reinforcement Requirements

ASME B31.1 Power Piping Code

ASME B31.3 Refinery Code

Forging Markings

Anvil **Anvilets** are clearly marked with the following:

- Outlet size
- Range of run pipe sizes that the **Anvilet** will fit
- The weight, schedule number, or pressure class
- The material specification
- Steel heat code identification

Installation Note

Anvil **Anvilets** are designed to have no more than a $\frac{1}{16}$ " gap (1.6mm) between the base or skirt of the **Anvilet** when it is seated directly upon the appropriate run pipe. However, it is recommended that the skirt of **Anvilets** be held slightly above the run pipe and tack welded to provide a small continuous root gap between the skirt and run pipe before completing the all-around welding beads or fillet.

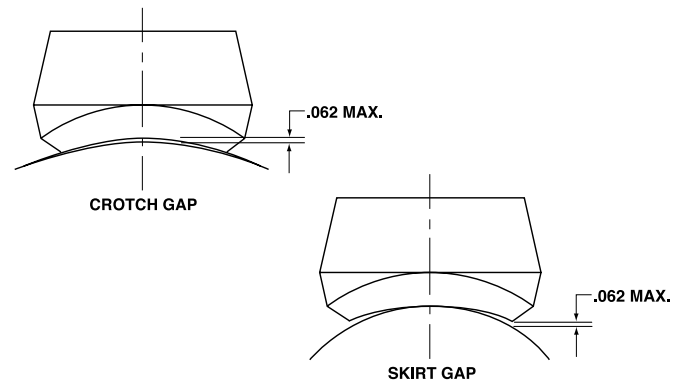

Specials

Your local Anvil Branch will be more than happy to assist you with specially machined outlets and those made of alloy material.

Pressure Temperature Ratings

MSS standard Practice SP-97 gives the following correlation between fitting pressure class and pipe schedule number/wall thickness designation for calculation of pressure-temperature ratings:

Branch Connection Type	Pressure Class of Fitting	Branch Connection Size		Pipe Wall for Rating Basis
		NPS	DN	
Buttweld	STD	1/8 - 24	6 - 600	STD
	XS/XH	1/8 - 24	6 - 600	XS/XH
	SCH 160	1/2 - 6	15 - 150	SCH 160
Threaded	3,000	1/4 - 4	8 - 100	XS/XH
	6,000	1/2 - 2	15 - 50	SCH 160
Socket-Welding	3,000	1/2 - 2	15 - 50	XS/XH
	6,000	1/2 - 2	15 - 50	SCH 160

The maximum allowable pressure of a fitting is computed in accordance with the applicable piping code or regulation for straight seamless header (run) pipe or for material of equivalent composition and mechanical properties to the fitting. Any corrosion or mechanical allowances and any reduction in allowable stress due to temperature or other service conditions, must be applied to the pipe and fitting alike.

Engineering Specifications

Universal Forged Steel Anvilets Run Size Combinations

		Outlet Size (in)											
Buttweld Standard	1/4	3/8	1/2	3/4	1	1 1/4	1 1/2	2	2 1/2	3	4	6	
		1/4	1/2 - 3/8	1 - 1/2	2 - 3/4	1	1 1/4	1 1/2	2	2 1/2	3	4	6
	36 - 3/8	36 - 3/4	36 - 1 1/4	36 - 2 1/2	1 1/2 - 1 1/4	2 - 1 1/2	3 1/2 - 2	3 - 2 1/2	4 - 3	4 - 3 1/2	6 - 5	8	
					36 - 2	6 - 2 1/2	36 - 4	6 - 3 1/2	10 - 5	6 - 5	10 - 8	10	
						36 - 8		36 - 8	36 - 12	14 - 8	20 - 12	14 - 12	
										36 - 16	36 - 22	18 - 16	
												24 - 20	
												34 - 26	
												42 - 36	
Buttweld Extra Strong	1/4	3/8	1/2	3/4	1	1 1/4	1 1/2	2	2 1/2	3	4	6	
	36 - 1/4	3/8	3/4 - 1/2	1 1/2 - 3/4	1	2 - 1 1/4	1 1/2	2	2 1/2	3	4	6	
		36 - 1/2	36 - 1	36 - 2	1 1/2 - 1 1/4	5 - 2 1/2	3 1/2 - 2	3 - 2 1/2	4 - 3	4 - 3 1/2	6 - 5	8	
					36 - 2	36 - 6	36 - 4	6 - 3 1/2	10 - 5	6 - 5	10 - 8	10	
								36 - 8	36 - 12	14 - 8	20 - 12	14 - 12	
										36 - 1	36 - 22	18 - 16	
												24 - 20	
												34 - 26	
												42 - 36	

		Outlet Size (in)											
Threaded Class 3000	1/4	3/8	1/2	3/4	1	1 1/4	1 1/2	2	2 1/2	3	4		
		3/8 - 1/4	1 - 3/8	1/2	1 1/4 - 3/4	1	1 1/2 - 1 1/4	1 1/2	2	2 1/2	3	4	
	36 - 1/2	36 - 1 1/4	36 - 3/4	36 - 1 1/2	2 1/2 - 1 1/4	3 1/2 - 2	2 1/2 - 2	3 1/2 - 2 1/2	3 1/2 - 3	5 - 3 1/2	6 - 5		
					36 - 3	36 - 4	5 - 3	6 - 4	6 - 4	14 - 6	10 - 8		
							36 - 6	36 - 8	36 - 8	36 - 16	20 - 12		
												36 - 22	
Threaded Class 6000	1/4	3/8	1/2	3/4	1	1 1/4	1 1/2	2	2 1/2	3	4		
	36 - 1/2	36 - 1 1/4	36 - 3/4	1 1/4 - 1	2 1/2 - 1 1/4	3 1/2 - 2	2 1/2 - 2	3 1/2 - 2 1/2	3 1/2 - 3	3 1/2	5		
			36 - 1 1/2	36 - 3	8 - 4	5 - 3	6 - 4	5 - 4	4	6 - 5	10 - 8		
					36 - 10	36 - 6	36 - 8	10 - 6	6 - 5	18 - 12			
								26 - 12	12 - 8	18 - 12			
								36 - 28	36 - 14	36 - 20			

		Outlet Size (in)											
Socket-Weld Class 3000	1/4	3/8	1/2	3/4	1	1 1/4	1 1/2	2	2 1/2	3	4		
		1/4	1/2 - 3/8	1/2	1 1/4 - 3/4	1	1 1/2 - 1 1/4	1 1/2	2	2 1/2	3	4	
	36 - 3/8	36 - 3/4	36 - 3/4	36 - 1 1/2	2 1/2 - 1 1/4	3 1/2 - 2	2 1/2 - 2	3 1/2 - 2 1/2	3 1/2 - 3	5 - 3 1/2	6 - 5		
					36 - 3	36 - 4	5 - 3	6 - 4	6 - 4	14 - 6	10 - 8		
							36 - 6	36 - 8	36 - 8	36 - 16	20 - 12		
												36 - 22	
Socket-Weld Class 6000	1/4	3/8	1/2	3/4	1	1 1/4	1 1/2	2	2 1/2	3	4		
	36 - 1/4	36 - 3/8	1/2	1 - 3/4	1	1 1/4	1 1/2	2	3 - 2 1/2	3 1/2 - 3	4		
		36 - 3/4	36 - 1 1/4	2 1/2 - 1 1/4	4 - 1 1/2	2 1/2 - 2	3 1/2 - 2 1/2	5 - 3 1/2	5 - 4	5			
				36 - 3	36 - 5	5 - 3	6 - 4	18 - 6	10 - 6	8 - 6			
						36 - 6	36 - 8	36 - 20	26 - 12	14 - 10			
									36 - 28	36 - 16			