



# ICM325HNV

## High Voltage Head Pressure Control with Optional Heat Pump Override

Temperature sensitive control regulates head pressure



### Installation, Operation & Application Guide

For more information on our complete range of American-made products – plus wiring diagrams, troubleshooting tips and more, visit us at [www.icmcontrols.com](http://www.icmcontrols.com)



**Installation of the ICM325HNV shall be performed by trained technicians only. Adhere to all local and national electric codes. Disconnect all power to the system before making any connections.**

### Specifications

- **Line voltage:** 120-600 VAC
  - **Control voltage:** 18-30 VAC
  - **Frequency:** 50-60 Hz
  - **Operating temperature:** -40°F to +176°F (-40°C to +75°C)
  - **Sensors:** 10K ohms at 77°F (25°C)
  - **Heat pump override:** 24 VAC N.C. or N.O.
- \* **Note:** A maximum of three sensors can be connected to the control.
- **Weight:** 12 ounces (341 grams)
  - \* **Note:** The ICM325HNV should be applied to motors and equipment that have been designated by their respective manufacturers as capable of being speed controlled.
- **Mounting:**
    - Surface mount using (4) #8 screws
    - The ICM325HNV should be surface mounted to a clean metal or other thermally conductive surface for maximum heat dissipation
    - It is recommended that the ICM325HNV be mounted away from the condenser exhaust air in order to maintain lower operating temperatures

### Wiring Diagrams

#### Connections for ICM325HNV at 120/208/240 VAC

1. Remove power from system.
2. Field install a wire from **Line 1** wire to **Line 1** terminal.
3. Cut **Line 2** wire; affix motor side to **Motor 2** terminal and line side to **Line 2** terminal.
4. Make 24 VAC and temperature probe connections.
5. Verify wiring is correct.
6. Power up system and check operation.

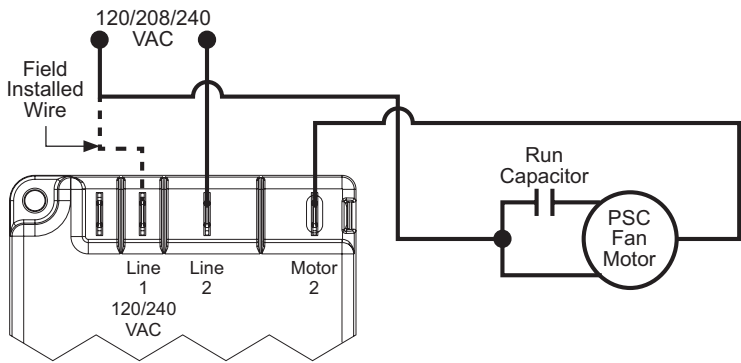
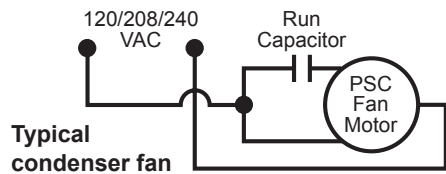

#### Connections for ICM325HNV at 480 VAC

1. Remove power from system.
2. Field install a wire from **Line 1** wire to **Line 1** terminal.
3. Cut **Line 2** wire; affix motor side to **Motor 2** terminal and line side to **Line 2** terminal.
4. Make 24 VAC and temperature probe connections.
5. Verify wiring is correct.
6. Power up system and check operation.

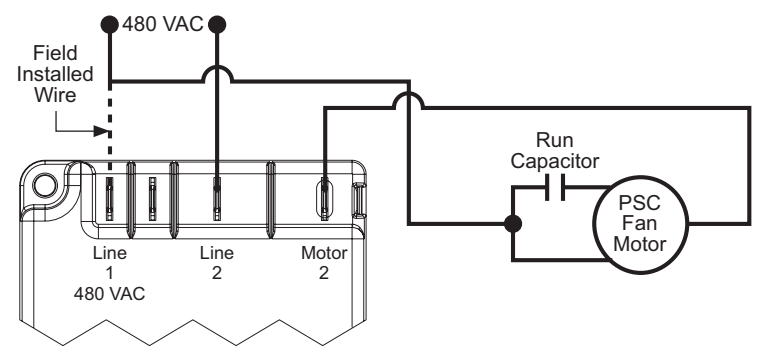
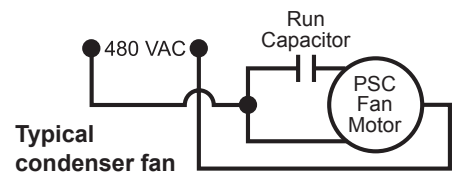

#### Connections for Heat Pump System at 120/208/240 VAC

1. Remove power from system.
2. Field install a wire from **Line 1** wire to **Line 1** terminal.
3. Cut **Line 2** wire; affix the common from the defrost board's fan relay to the **Motor 2** terminal and the Line from the contactor to the **Line 2** terminal.
4. Make 24 VAC, probe and HP connections.
5. Verify wiring is correct.
6. Power up system and check operation.

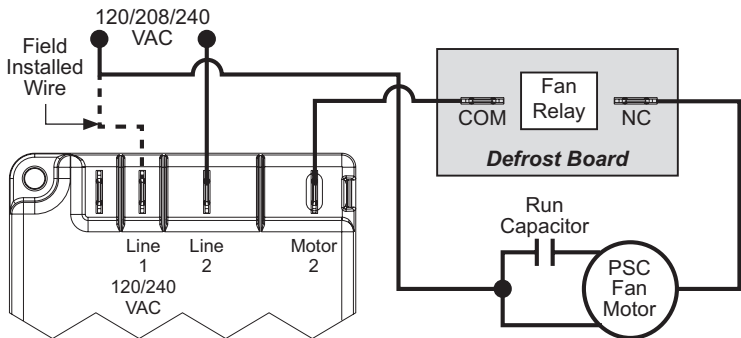

#### Connections for Heat Pump System at 480 VAC

1. Remove power from system.
2. Field install a wire from **Line 1** wire to **Line 1** terminal.
3. Cut **Line 2** wire; affix the common from the defrost board's fan relay to the **Motor 2** terminal and the Line from the contactor to the **Line 2** terminal.
4. Make 24 VAC, probe and HP connections.
5. Verify wiring is correct.
6. Power up system and check operation.

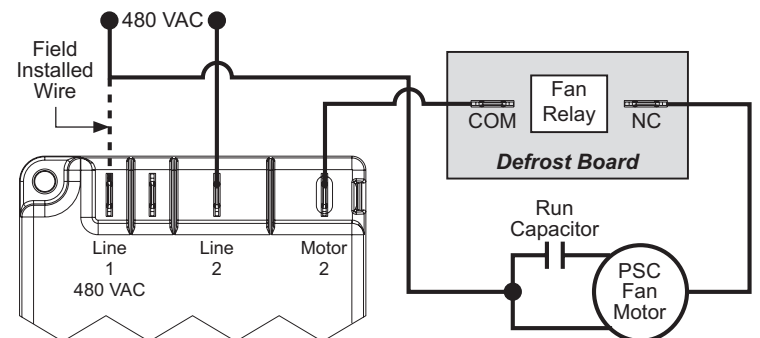

#### Connecting the Probe

1. Install the temperature probe several bends into the condenser. It can be attached to the U-bend or placed between the fins in the upper 1/3 of the condenser (see other side for more information).
- \* **Note:** The response of the system can be fine tuned by repositioning the probe. Place the probe on the condenser where it is 100°F when pressures are correct for best response.

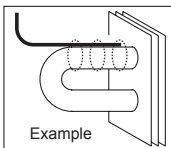

2. Connect the two wires from the sensor to the terminal block where it is marked **PROBE S1**. If additional probes are necessary for multiple refrigerant circuits, they may be attached to terminals marked **PROBE S2** and **PROBE S3**.

\* **Note:** The control will respond to the probe that senses the highest temperature.

#### Connections for Air Conditioning Only

1. **For non-heat pump applications,** the heat pump select jumper must be in the **Default (N.O.)** position, and the HP terminals must be left unconnected.
2. Set the **Cutout Speed** and the **Hard Start Time** to the appropriate positions for the type of motor you have (see other side).

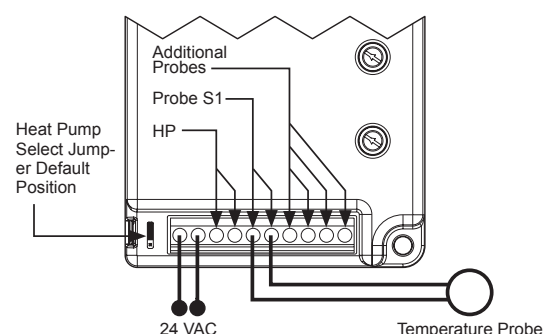

## Connections for Heat Pump Systems

1. The **Heat Pump** terminals accept the 24 VAC signal from the reversing valve holding coil. Make a parallel connection from the reversing valve to the HP terminals.

✱ **Note:** Do not apply a voltage higher than 30 VAC to the HP terminals.

2. If the **Heat Pump** is in the **Heating** mode and the reversing valve is energized, then the **Heat Pump Select** jumper must be in the **Default (N.O.)** position.

3. If the **Heat Pump** is in the **Heating** mode and the reversing valve is not energized, then the **Heat Pump Select** jumper must be in the **N.C.** position.

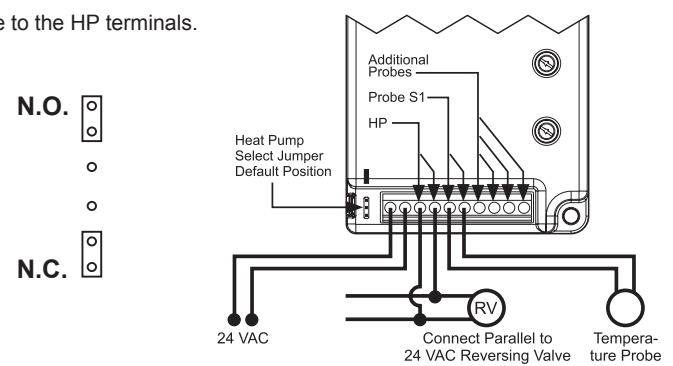

## Mode of Operations

### Normal Function

With probe temperatures above 100°F, the control applies full voltage to the motor. The green light is illuminated (full speed LED).

With probe temperatures between 70°F and 100°F, the motor speed is proportional to the probe temperature. The yellow light is illuminated (variable speed LED).

When the motor starts at temperatures between 70°F and 100°F, it will hard start for the length of time dictated by the hard start dial setting. After the hard start time has elapsed, the motor speed is controlled by the probe temperature.

As the temperature being sensed decreases, the output voltage decreases. The output voltage may decrease to the determined cutout speed dictated by the cutout speed dial. Upon reaching the cutout speed setting, the output voltage goes to zero volts.

System restart will occur when the temperature exceeds 70°F.

With probe temperatures below 70°F, the motor remains off. The green light and the yellow light are off.

### Heat Pump Bypass Operation

Heat pump bypass mode runs the fan at full speed when the system is operating in heat mode. This moves as much air as possible across the condenser coil.

If the heat pump select jumper is in the N.O. position, and 24 VAC is applied to the HP terminals, the motor will be brought to full speed.

If the heat pump select jumper is in the N.C. position, and 24 VAC is not present at the HP terminals, the motor will be brought to full speed.

A separate relay is not needed.

## Setting the Cutout Speed

The cutout speed dial adjusts the motor voltage range. Set the cutout voltage dial according to the type of motor you have.

### Sleeve Bearing Motors:

Set the cutout speed dial to the middle of the sleeve bearing range. In this range, the motor can run down approximately 40-50% of the full line voltage, which allows sufficient RPMs for cooling and lubrication.

**CAUTION!** With sleeve bearing motors, it is important not to adjust outside the sleeve bearing range or bearing failure may result.

**Ball Bearing Motors:** Set the cutout speed dial to the **MIN** position in the ball bearing range. This position offers the greatest range of speed control. At the **MIN** setting the motor can run down to approximately 20-30% of the full line voltage.

✱ **Note:** After starting at the recommended settings for either sleeve or ball bearing motors, you can fine tune the cutout speed to achieve the desired results.

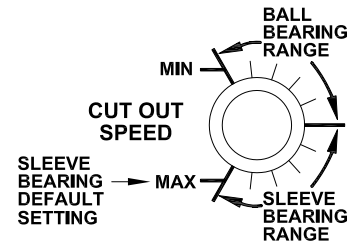

## Setting the Hard Start Speed

During the **Hard Start** mode, full voltage is applied to the motor during startup to overcome wind milling and to lubricate the bearings.

The position of the hard start dial determines the time period of the hard start mode. The dial can be adjusted between 0.1 second and approximately 5 seconds.

Set the hard start dial according to the type of motor you have. If you have a **ball bearing motor**, set the hard start dial to the **MIN** position. If you have a **sleeve bearing motor**, set the hard start dial to the middle of the sleeve bearing range.

After you begin at the recommended setting, you can fine tune the hard start time within the recommended range for the type of motor you have.

It is recommended that you use the minimum possible hard start time to avoid blowing too much cold air over the condenser.

**Hard Start** mode is activated when 24 VAC is applied (or disconnected and re-applied) or the probe temperature increases to above 70°F. The hard start mode applies full voltage to the motor for the set time period. Afterwards, the motor speed is dictated by the temperature sensor(s).

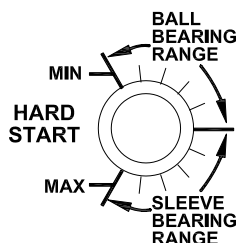

## Troubleshooting

Symptom	Problem
Unit fails to start	The sensor may not be connected or it is defective. With the probe disconnected, use an ohmmeter to measure the resistance between the probe wires. It should match the chart in Appendix B. If you read an OPEN or SHORT, replace the sensor.
Fuse and/or circuit blows	The unit has been miswired and may be permanently damaged.
The fan cycles from full ON to full OFF with little or no modulation	Turn OFF the control circuit power (24 VAC). Re-apply 24 VAC power and confirm hard start operation. Reduce the hard start period to the minimum setting required to accelerate the fan. Excessive hard starting causes large pressure drops by running too much cold air over the condenser. Should the cycling persist, move the probe up several bends into the condenser to increase the sensitivity to condensing temperature. Adjust probe location. Fine tune cutout adjustment.
The fan does not come on at all	Using an AC voltmeter, measure the voltage between the 24 VAC terminals. It should read approximately 24 volts. Measure the line voltage between <b>LINE 1</b> and <b>LINE 2</b> to confirm that the line voltage is present. Remove the thermistor probe from the terminal block and measure its resistance at ambient temperature. Compare your reading at the appropriate temperature in Appendix B to see if the actual resistance approximates the listed value. Next, hold the probe in your hand and confirm that the resistance decreases. Place a temporary jumper across the <b>S2</b> or <b>S3</b> terminals. Fan should run at full speed. If it does, recheck probe connection and verify probe is operating correctly.
The high pressure switch trips off	Move the probe further into the condenser where the temperature is higher. This will produce a higher fan RPM and will decrease the head pressure. Fine adjust the cutout and hard start settings.
Green and Yellow LEDs alternate	Verify 24 VAC is available at the 24 VAC terminals.

## Appendix A

### Mounting a sensor into the condenser vs. mounting it on the liquid line

When a sensor is mounted into the condenser, the control responds more rapidly to changes in head pressure than when it is mounted on the liquid line. This is especially true for high efficiency condensers.

When the sensor is mounted on the liquid line, the control responds more slowly and the results can be a fan that cycles on and off.

Whenever possible, it is preferable to mount the sensor in the upper 1/3 of the condenser instead of mounting it on the liquid line (see illustration below). A spot on the condenser that is 100°F when the pressures are correct is ideal.

## Appendix B

### Temperature vs. Probe Resistance

°C	°F	Resistance (KΩ)
0°	32°	32.7
5°	41°	25.4
10°	50°	19.9
15°	59°	15.7
20°	68°	12.5
25°	77°	10.0
30°	86°	8.1
35°	95°	6.5
40°	104°	5.3
45°	113°	4.4
50°	122°	3.6

## ICM325HNV Typical Installation

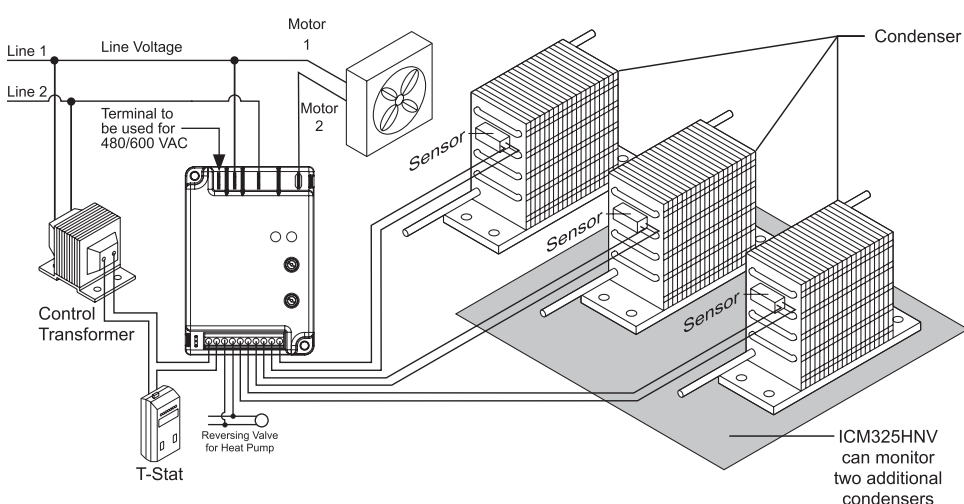

## ONE-YEAR LIMITED WARRANTY

The Seller warrants its products against defects in material or workmanship for a period of one (1) year from the date of manufacture. The liability of the Seller is limited, at its option, to repair, replace or issue a non-case credit for the purchase prices of the goods which are provided to be defective. The warranty and remedies set forth herein do not apply to any goods or parts thereof which have been subjected to misuse including any use or application in violation of the Seller's instructions, neglect, tampering, improper storage, incorrect installation or servicing not performed by the Seller. In order to permit the Seller to properly administer the warranty, the Buyer shall: 1) Notify the Seller promptly of any claim, submitting date code information or any other pertinent data as requested by the Seller. 2) Permit the Seller to inspect and test the product claimed to be defective. Items claimed to be defective and are determined by Seller to be non-defective are subject to a \$30.00 per hour inspection fee. This warranty constitutes the Seller's sole liability hereunder and is in lieu of any other warranty expressed, implied or statutory. Unless otherwise stated in writing, Seller makes no warranty that the goods depicted or described herein are fit for any particular purpose.



7313 William Barry Blvd., North Syracuse, NY 13212  
(Toll Free) 800-365-5525 (Phone) 315-233-5266 (Fax) 315-233-5276

www.icmcontrols.com