

ENCLOSURE

MH1200 Series

Metal Housing, NEMA 1, 8.30" H x 7.70" W x 3.90" D

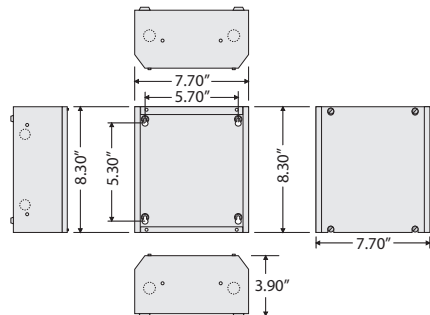

MH1200 SERIES ASSEMBLIES			
Model #	Enclosure	Plastic Snap Track	Weight
MH1200	MH1200		3.86 lbs.
MH1210	MH1200	MT4-8	4.06 lbs.
MH1220	MH1200	MT212-8	4.00 lbs.



SPECIFICATIONS

Construction: 18 Gauge Steel

Cover Type: Screw Down Cover

Approvals: UL Listed, C-UL, CE Approved, RoHS

Notes:

- Consult factory for custom colors for large orders.