

Combination Mechanical Water Feeder/ Low Water Cut-Offs

Series 51-S/51-S-2 Water Feeder/Low Water Cut-Offs

Replacement Head Mechanisms

For Series	Repl. Head Model No.	Part Number	Description	Weight lbs. (kg)
51-S	51-S-2-HD or	136200	Head mechanism w/ No. 2 switch	20.5 (9.3)
	51-S-2M-HD	136250	51-S-2-HD w/manual reset	21.7 (9.8)

Components (shown on page 47)

Item Number	Part Number	Model Number	Description	Weight lbs. (kg)
1	110000	2	Low water cut-off switch	1.0 (0.5)
2	110100	2-M	No. 2 w/manual reset	1.0 (0.5)
3	310437	FLT-51-05	Float (see note following page)	2.5 (1.1)
4	304100	F-26	Gasket	0.1 (.05)
5	312800	37-27	Gasket	0.1 (.05)
6	302900	CO-106	Cam assembly	0.1 (.05)
7	310439	BA-51-05	Bellows bracket assembly (includes item 4) (see note following page)	1.0 (0.7)
8	342100	SA51S-6	Valve assembly	3.0 (1.4)
9	316200	51S-114	Valve seat	0.8 (.36)
10	342200	SA51-9	Strainer assembly	0.1 (.05)
11	312900	37-28	Gasket	0.1 (.05)
12	324435	37-101	Tetraseal O-ring	0.1 (.05)
13	340700	SA37-38	Strainer basket (includes item 12)	0.7 (.32)



Series 51-S



Series 51-S-2

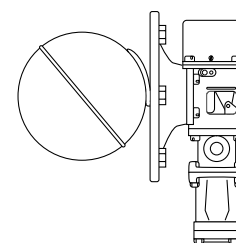

Model 51-S-2-HD

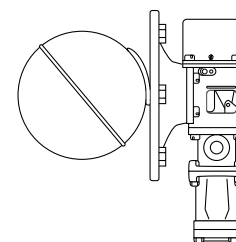

Model 51-S-2M-HD

Combination Mechanical Water Feeder/ Low Water Cut-Offs

Series 51-S/51-S-2 (continued)
Water Feeder/Low Water Cut-Offs

Components

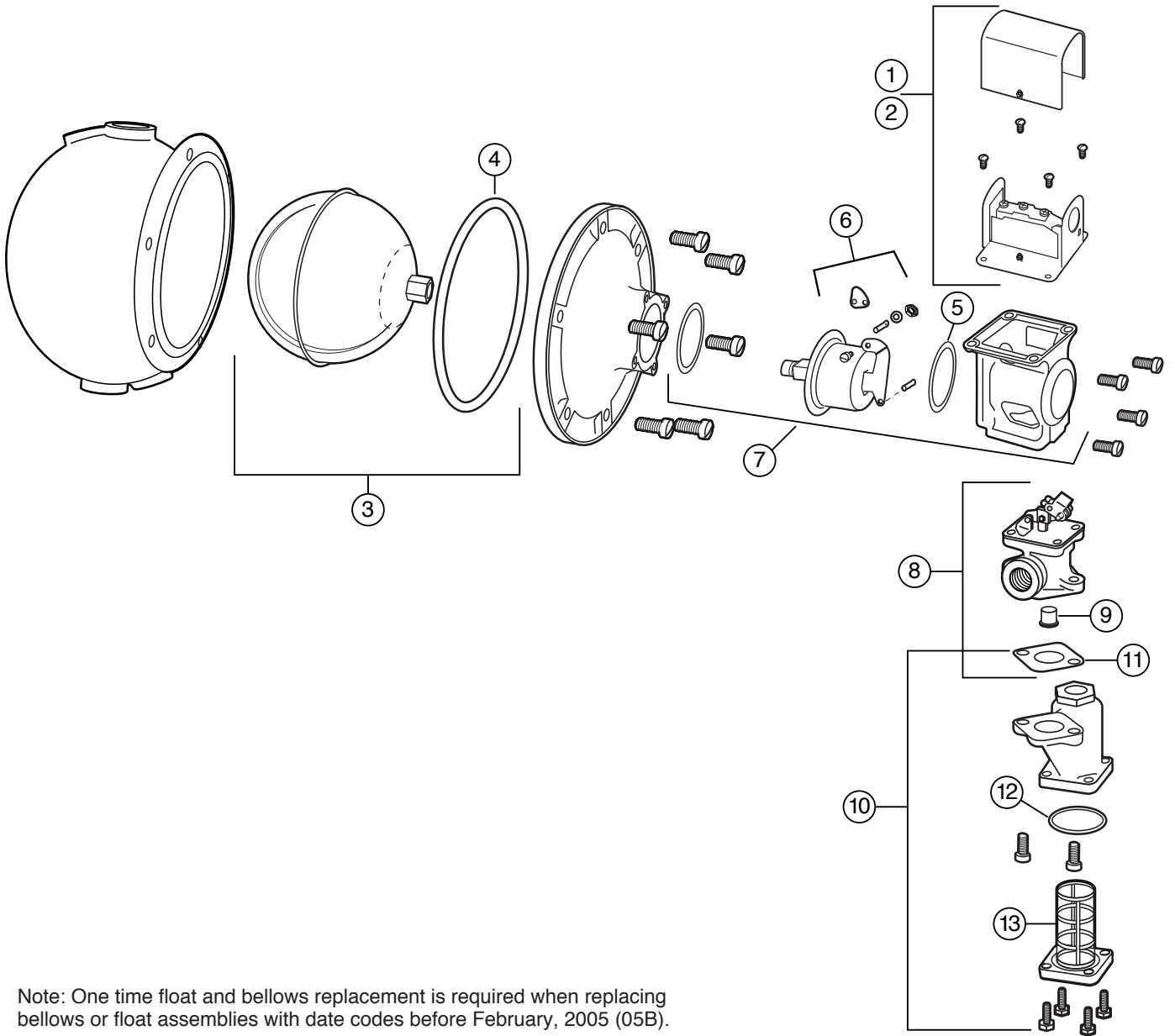

Note: One time float and bellows replacement is required when replacing bellows or float assemblies with date codes before February, 2005 (05B).