

OVC# SC800SW/TE

Socket Weld End & Threaded End Forged Steel Swing Check Valve

Features

- Basic design: API 602
- Test: API 598
- Socket weld dimensions: ASME B16.11
- Screw end dimensions: ASME B16.11

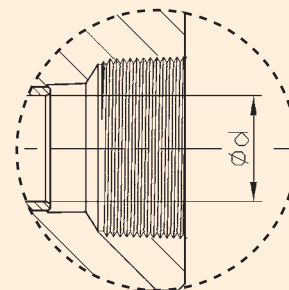
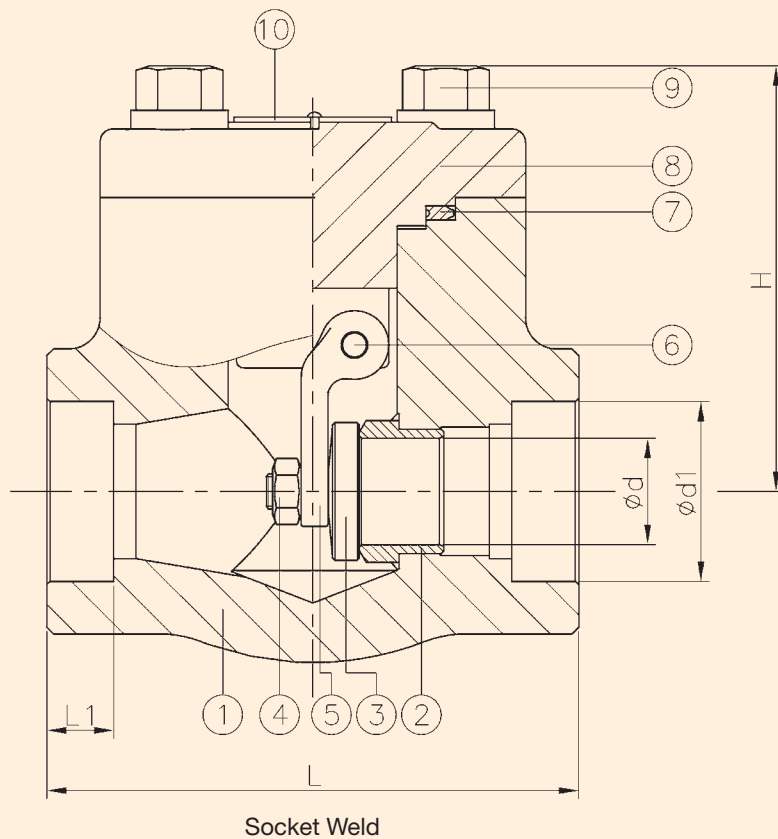

Threaded End

NO.	DESCRIPTION	MATERIAL
1	BODY	ASTM A105N
2	SEAT	ASTM A276-410 + STL
3	DISC	ASTM A276-420
4	NUT	ASTM A194-8
5	CARRIER	ASTM A351-CF8
6	PIN	ASTM A276-304
7	GASKET	304 + GRAPHITE
8	CAP	ASTM A105N
9	BOLT	ASTM A193-B7
10	NAMEPLATE	ALUMINUM

NPS	d	d1	L	L1	H	Weight (lb)
1/4"	0.30	0.56	3.11	0.39	2.28	3.3
3/8"	0.37	0.69	3.11	0.39	2.28	3.3
1/2"	0.51	0.86	3.11	0.39	2.28	3.1
3/4"	0.51	1.07	3.62	0.51	2.28	3.7
1"	0.71	1.33	4.37	0.51	2.95	5.5
1-1/4"	0.94	1.68	4.72	0.51	3.27	8.0
1-1/2"	1.14	1.92	4.72	0.51	3.70	9.7
2"	1.44	2.41	5.51	0.63	4.21	16.1