

ENCLOSED UPS INTERFACE MODULE

PSH2C2RB10-L

Enclosed 2.75" Track Mount Power Control Center, with 10 Amp Switch / Circuit Breaker, Two (2) 120 Vac Outlets, Terminals, 120 Vac Input. **(Status Contacts)**

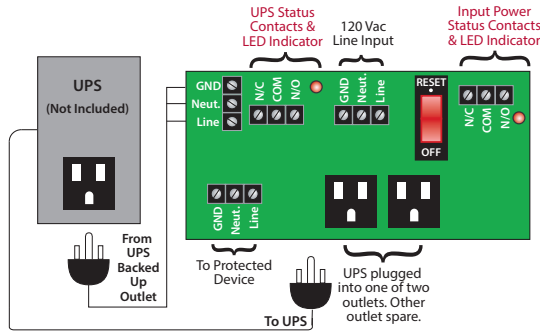

Shown Without Cover



Shown With Cover

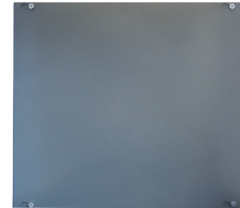

SPECIFICATIONS

Operating Temperature: -30 to 140° F
Humidity Range: 5 to 95% (noncondensing)
Main Breaker ON/OFF: Switch / Breaker (10 Amp)
Approvals: UL Listed, UL916, C-UL, CE, RoHS
Dimensions: 14.000" x 16.000" x 6.000"
 Metal Housing with Screw Cover
Weight: 14.76 lbs.

Line Input Status Contacts and UPS Output Status Contacts Rated:
 10 Amp @ 277 Vac General Use
 10 Amp @ 30 Vdc N/O
 7 Amp @ 30 Vdc N/C
 1/2 HP @ 125 Vac
 1/4 HP @ 277 Vac
 1000 VA @ 120 Vac Magnetic Ballast N/C
 C300 Pilot Duty
 16.8 VA @ 24 Vac Pilot Duty

Notes:

- Track mounted interface board may be ordered separately as model PSMN2C2RB10, to be used with any commercial UPS with appropriate ratings for the circuit breaker.
- Circuit breaker for short-circuit protection.
- 14/3 Line Cord included (3').
- Use with UPS devices rated 1000 VA or less.
 - Max. size: 14.000" x 10.000" x 5.500"
 - 120 Vac, 600 W max., 8.3 Amp max.
- UPS is not included.
- To order a kit with a UPS, see PSH850-UPS-STAT.

POWER CONTROL