

RM Series Radiant Manifolds- RM200, RM300 & RM400

1" SUPPLY & RETURN BRONZE MODELS

PRODUCT DATA

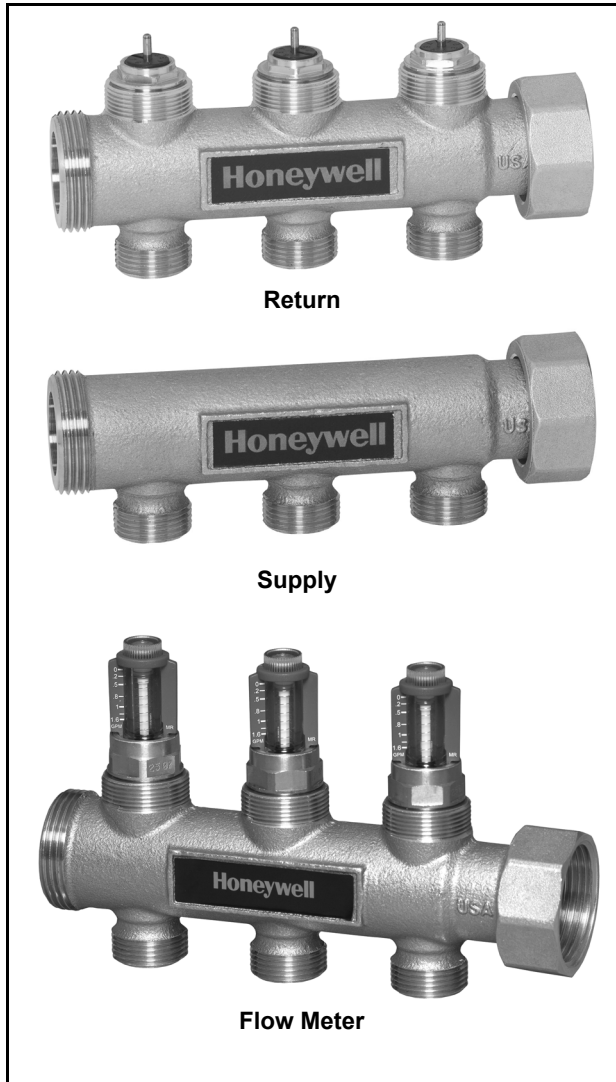

GENERAL

Radiant Manifolds for Hot Water Distribution

Manifolds are used to control individual heating loop flow and temperature controls through both Supply and Return configurations. Individual tubing loops are connected to the manifolds through connection adapters. Manifolds can be easily grouped together in configurations of 2 Port, 3 Port and 4 Port by using built-in union nut adapters allowing different zoning configurations to meet job needs.

Return Manifolds-With Valves

Incorporate built-in balancing valves to allow flow adjustment and balance for individual heating loops.

Supply Manifolds-Without Valves

Used in combination with Return manifolds that contain valves for individual loop flow and temperature control.

Supply Manifolds - With Flow Meters

Incorporate built-in flow meters to allow visual flow indication for individual heating loops. Used in combination with Return Manifolds.

SPECIFICATIONS

Materials: Cast Bronze.

Maximum Operating Temperature: 220 °F (104 °C).

Maximum Operating Pressure: 125 PSI (861.8 lpm).

Flow: 3.5 gpm (13.2 lpm) per branch.

Dimensions: See Table 1.



PRE-BALANCING ZONES

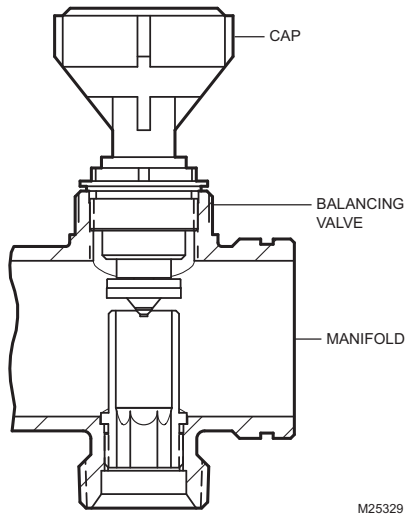

Fig. 1. Balancing Cartridge.

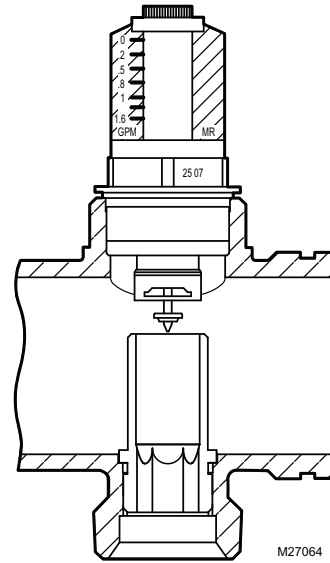

Fig. 2. Flow Meter

Flow meters provide visual indication of individual heating loop flow. Use the pre-balancing cartridge adjustment feature to balance individual heating loop flow as required

RM Series					
Turns from fully closed	1/4	1/2	1	1 1/2	2
Flow rate in gpm (lpm)	0.7 (2.6)	1.4 (5.3)	2.1 (7.9)	2.8 (10.6)	3.5 (13.2)

Each valve station has a built in balancing plug which permits pre-balancing of zones. To balance, remove the protective cap and locate the balancing plug (with slot) on top of the valve. To turn the plug, turn the cap upside down and place the slot adjustment end over the cartridge stem and place the protruding tip into the slot. Close the valve by turning clockwise until it stops. To adjust the cartridge setting, turn counter clockwise to achieve the desired balance setting for the individual zoning loops.

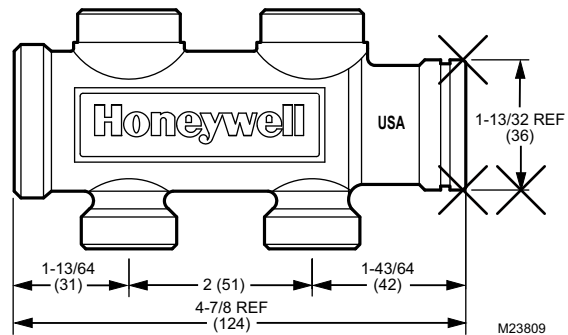

Fig. 3. Radiant Manifold Dimensions

Table 1. Dimensions in Inches (mm).

OS Model	Length	Width	Height	Port C-To-C
RM200WOV	4.870 (123.698)	1.600 (40.640)	1.670 (42.418)	1.968 (49.987)
RM300WOV	6.839 (173.711)	1.600 (40.640)	1.670 (42.418)	1.968 (49.987)
RM400WOV	8.807 (223.698)	1.600 (40.640)	1.670 (42.418)	1.968 (49.987)
RM200WV	4.870 (123.698)	1.600 (40.640)	3.280 (83.312)	1.968 (49.987)
RM300WV	6.839 (173.711)	1.600 (40.640)	3.280 (83.312)	1.968 (49.987)
RM400WV	8.807 (223.698)	1.600 (40.640)	3.280 (83.312)	1.968 (49.987)
RM200WFM	4.870 (123.698)	1.600 (40.640)	4.500 (114.30)	1.968 (49.987)
RM300WFM	6.839 (173.711)	1.600 (40.640)	4.500 (114.30)	1.968 (49.987)
RM400WFM	8.807 (223.698)	1.600 (40.640)	4.500 (114.30)	1.968 (49.987)

Automation and Control Solutions

Honeywell International Inc.
1985 Douglas Drive North
Golden Valley, MN 55422
customer.honeywell.com

Honeywell Limited-Honeywell Limitée
35 Dynamic Drive
Toronto, Ontario M1V 4Z9

Honeywell

