

Single Sphere, Dual Sphere, & Wide Arch Rubber Expansion Joints



Rubber expansion joints are available from Flex-Weld, Inc. / Keflex HVAC Products as standard or custom offerings. We have a wider array of material and configuration types than any other manufacturer.

Our products are designed and engineered to carry a variety of media in pressure or vacuum applications. They absorb harmful system vibration and contract or expand in response to pipe motion induced from thermal expansion and contraction, respectively.

We offer any type of rubber expansion joints from single sphere to triple, floating flange to cable-tied, standard sizes and diameters to custom lengths and reducers. Material ranges from standard Neoprene and EPDM to *Hypalon or Teflon.

MODELS & DESCRIPTION	
Model	Type & Material
SNN	Single Sphere, Neoprene
SEE	Single Sphere, EPDM
TNN	Twin Sphere, Neoprene
TEE	Twin Sphere, EPDM
CNN	Twin Sphere w/Female Union, Neoprene
CEE	Twin Sphere w/Female Union, EPDM
MARINE FLEX	Wide Arch, Neoprene

*Hypalon and Teflon, as used throughout this brochure, are registered trademarks of DuPont Dow Elastomers and the DuPont Company, respectively.

RUBBER EXPANSION JOINTS

Rubber Expansion Joints are inexpensive products that provide critical protection of piping and mechanical equipment in a multitude of engineered applications. If designed, manufactured, applied and installed properly, rubber expansion joints can serve to:

- Absorb pump and mechanical equipment vibration
- Absorb and deaden noise generated by the system
- Absorb axial motion in compression and extension
- Accommodate lateral offset induced from transient system movements
- Allow for misalignment in problematic pipe runs
- Reduce stress on mechanical equipment, piping and solid joints and unions.
- Eliminate electrolysis in dissimilar metals employed in the same pipe system Protect piping systems against pressure surges

ADVANTAGES OVER METAL EXPANSION JOINTS

- Noise Reduction
- Low Cost
- Space saving design

FEATURES / SERVICES

- Higher Pressures
- Lower Force to Actuate
- Large Stocking Inventory with same day shipping on standards
- Engineering Analysis
- Metallurgical Analysis
- On-Site Consultation
- Chemical Media Analysis
- Retrofitting
- Cross-Reference
- Engineering Staff Available for Consultation 24/7

OPTIONS—STANDARD & CUSTOM

Materials:

- Neoprene
- EPDM
- Teflon
- Butyl
- Hypalon
- Nitrile
- All Domestic

Styles:

- Sphere Type – Single & Dual
- Wide Arch
- Reducing
- Cable-Tied
- Female Union
- Custom Styles & Lengths

Flange Type:

- Floating
- Integrated
- Custom

Drill Pattern:

- Standard
- Navy

Shape:

- Round
- Rectangular
- Oval
- Custom

SELECTION APPLICATION GUIDELINES

- **Single Sphere**— Used in tight spaces
- **Twin Sphere**—Use when additional movement is necessary
- **Wide Arch**— Non-clogging
- **Neoprene**— Cold water
- **EPDM**— Hot water applications
- **Floating Flanges**— Problematic bolt hole alignment
- **Control Rods**— Concerns over pipe anchoring and guiding

SINGLE RUBBER EXPANSION JOINTS—SERIES S

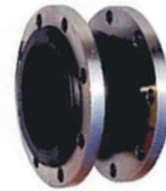

Sizes • Movements • Pressure • Weights

Nominal Pipe Size I.D. of E.J.	KEFLEX™ Model Number	F/F Installed Neutral Length	Allowable Movements from Neutral				Pressures @ 170° F		Weights	
			Axial Compression	Axial Extension	± Lateral Deflection	± Angular Deflection	Positive P.S.I.G.	Negative In. of Hg.	Joint & Flanges	Control Rod Set
1 ½	F014SNN060	6.0	.5	.375	.5	27°	225	26	6.1	4.6
2	F020SNN060	6.0	.5	.375	.5	20°	225	26	12.3	7.6
2 ½	F024SNN060	6.0	.5	.375	.5	17°	225	26	12.3	7.6
3	F030SNN060	6.0	.5	.375	.5	14°	225	26	14.0	8.3
4	F040SNN060	6.0	.75	.5	.5	14°	225	26	18.3	7.4
5	F050SNN060	6.0	.75	.5	.5	11°	225	26	22.8	8.3
6	F060SNN060	6.0	.75	.5	.5	9°	225	26	26.8	10.4
8	F080SNN060	6.0	.75	.5	.5	7°	225	26	40.6	13.4
10	F100SNN080	8.0	1.0	.625	.75	7°	225	26	56.6	21.3
12	F120SNN080	8.0	1.0	.625	.75	6°	225	26	83.0	27.0
14	F140SNN080	8.0	1.0	.625	.75	5°	150	26	115.0	28.0
16	F160SNN080	8.0	1.0	.625	.75	4°	125	26	165.0	26.8
18	F180SNN080	8.0	1.0	.625	.75	4°	125	26	168.0	31.4
20	F200SNN080	8.0	1.0	.625	.75	3°	125	26	170.0	32.4
24	F240SNN100	10.0	1.0	.625	.75	3°	110	26	225.0	45.0

Note: Replaces WA225NFF Series

TWIN SPHERE RUBBER EXPANSION JOINTS—SERIES T

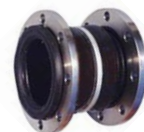

Sizes • Movements • Pressure • Weights										
Nominal Pipe Size I.D. of E.J.	KEFLEX™ Model Number	F/F Installed Neutral Length	Allowable Movements from Neutral				Pressures @ 170° F		Weights	
			Axial Compression	Axial Extension	± Lateral Deflection	± Angular Deflection	Positive P.S.I.G.	Negative In. of Hg.	Joint & Flanges	Control Rod Set
2	F020TNN070	7.0	2.0	1.18	1.75	45°	225	26	9.0	7.0
2 ½	F024TNN070	7.0	2.0	1.18	1.75	43°	225	26	13.3	8.0
3	F030TNN070	7.0	2.0	1.18	1.75	38°	225	26	14.3	8.6
4	F040TNN090	9.0	2.0	1.375	1.562	34°	225	26	20.3	8.0
5	F050TNN090	9.0	2.0	1.375	1.562	29°	225	26	24.5	8.3
6	F060TNN090	9.0	2.0	1.375	1.562	25°	225	26	29.5	11.7
8	F080TNN130	13.0	2.375	1.375	1.375	19°	225	26	43.8	15.4
10	F100TNN130	13.0	2.375	1.375	1.375	15°	225	26	65.5	24.5
12	F120TNN130	13.0	2.375	1.375	1.375	13°	225	26	95.0	31.0

Note: Replaces KTWNNFF Series

NOTES:

1. Dimensions in inches unless otherwise specified. Weights are approximate in pounds.
2. Pressure rating is based on 170° F operating temperature. At higher temperatures the pressure rating is reduced slightly. Refer to temperature/pressure relationship table.
3. Pressures shown are recommended "operating." Test pressure is 1.5 times "operating." Burst pressure is approximate 4 times "operating."
4. Vacuum rating is based on neutral installed length, without external load.
5. Products should not be installed "extended" on vacuum applications.
6. All expansion joints are furnished complete with retaining flanges. Control units are recommended.
7. Cover and tube elastomer is neoprene unless otherwise stated.
8. Contact factory for other available sizes.

Series S Single Sphere Connector

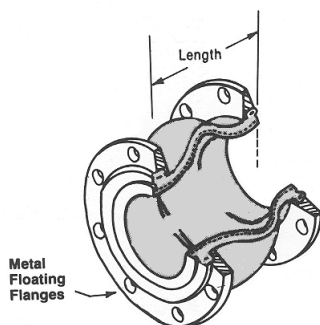

Control Rod/Unit Applications. Control unit assemblies are factory pre-set at the maximum allowable expansion and/or contraction of the connector. They are designed to absorb static pressure thrust developed at the expansion joint. When used in this manner, control unit assemblies are an additional safety factor, minimizing possible failure of the expansion joint or damage to the equipment.

Series T Twin Sphere Connector

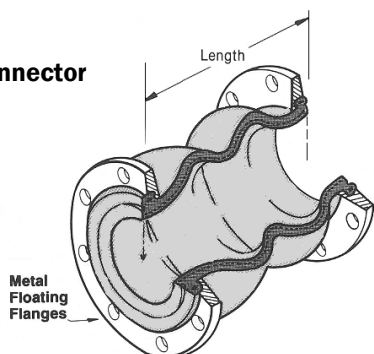

1. **Anchored Systems:** Control unit assemblies are not required in piping systems that are anchored on both sides of the expansion joint, provided piping movements are within the rated movements. A pump is not considered an anchor.
2. **Unanchored Systems:** Control unit assemblies are always recommended in unanchored systems. Additionally, control unit assemblies must be used when the maximum pressure exceeds the value shown, or the movement exceeds the rated movement.
3. **Spring Mounted Equipment:** Control unit assemblies are always recommended for spring mounted equipment. Control units must be used when the maximum pressure exceeds the control unit value shown, or the movement exceeds the rated movement. Additionally, when control units are not used, the expansion joint must be installed "extended" in accordance with the Installation Instructions.

SINGLE & TWIN SPHERE RUBBER EXPANSION JOINTS—SERIES S & T

Drilling				
Standard Flange Bolting Dimensions				
Pipe Size	Flange O.D.	Bolt Circle	# Holes	Bolt Hole Thread
1-1/2"	5.0	3.88	4	1/2 - 13 UNC
2"	6.0	4.75	4	5/8 - 11 UNC
2-1/2"	7.0	5.5	4	5/8 - 11 UNC
3"	7.5	6.0	4	5/8 - 11 UNC
4"	9.0	7.5	8	5/8 - 11 UNC
5"	10.0	8.5	8	3/4 - 10 UNC
6"	11.0	9.5	8	3/4 - 10 UNC
8"	13.5	11.75	8	3/4 - 10 UNC
10"	16.0	14.25	12	7/8 - 9 UNC
12"	19.0	17.0	12	7/8 - 9 UNC
14"	21.0	18.75	12	1 - 8 UNC
16"	23.5	21.25	16	1 - 8 UNC
18"	25.0	22.75	16	1-1/8 - 7 UNC
20"	27.5	25.0	20	1-1/8 - 7 UNC
22"	29.5	27.25	20	1-1/4 - 7 UNC
24"	32.1	29.5	20	1-1/4 - 7 UNC

Temperature / Pressure Relationship	
Temperature Degrees Fahrenheit	Pressure Derating Factors
	Series S / Series T
170	1.00
180	.93
190	.86
200	.80
210	.73
220	.67
225 (max.)	.63

Drilling meets 125/150 lb. Standards of: ANSI B16.1, B16.24, B16.5; AWWA C-207—Class D & F; MSS-SP 44 & 51

CONTROL RODS

Floating Flange and Control Unit

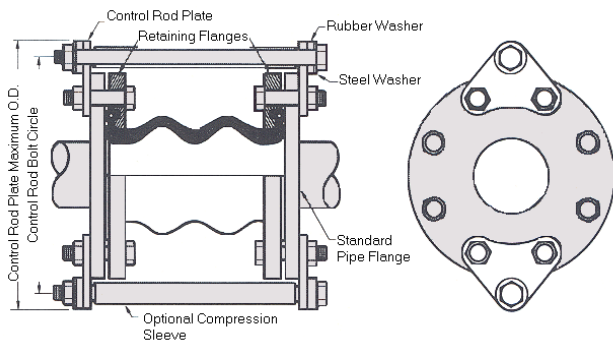

Technical Note: Flex-Weld strongly encourages the use of Control Rods in most, if not all, Rubber EJ applications. Most applications that utilize rubber expansion joints are not anchored properly. A simple pump connector does not protect against extreme stresses and strains produced by water hammer or air induced surge pressure, common to most applications, which greatly exceed normal system operating pressure.

Control Units				
Add On Type				
Pipe I.D.	Plate Width	# Rods	Rod Dia.	Pressure Rating
1-1/2"	.375	2	.5	510
2"	.375	2	.63	661
2-1/2"	.375	2	.63	529
3"	.375	2	.63	441
4"	.375	2	.63	311
5"	.375	2	.63	235
6"	.5	2	.63	186
8"	.5	2	.75	163
10"	.75	2	.88	163
12"	.75	2	1.0	160
14"	.75	2	1.0	112
16"	.75	2	1.13	113
18"	.75	2	1.13	94
20"	.75	2	1.13	79
22"	1.0	2	1.25	85
24"	1.0	2	1.25	74

THREADED METAL / RUBBER EXPANSION JOINT—C SERIES*



Styles • Sizes • Movements • Dimensions • Weights

Nominal Pipe Size / Connector I.D. C Series	"F" Installed Length				Total Travel		Allowable Movement from Neutral				Dimensions		Pressure @ 170°		Weights
	"F" Overall Neutral Length	Minimum Installed	Maximum Installed	Recommended Pipe Opening	Total Compressed	Total Extended	Axial Comp.	Axial Ext.	± Lateral Deflection	± Angular Deflection	"A" Length of Fitting	"B" Length of Rubber	Positive P.S.I.G.	Negative In. of Hg.	
3/4"	8.0	7.34 – 8.11		6.25	7.13 – 8.23		.87	.23	.87	32.2°	1.06	5.88	150	26	1.6
1"	8.0	7.34 – 8.11		6.25	7.13 – 8.23		.87	.23	.87	25.3°	1.14	5.72	150	26	2.6
1-1/4"	8.0	7.34 – 8.11		6.25	7.13 – 8.23		.87	.23	.87	20.7°	1.26	5.48	150	26	3.3
1-1/2"	8.0	7.34 – 8.11		6.25	7.13 – 8.23		.87	.23	.87	17.5°	1.30	5.40	150	26	4.0
2"	8.0	7.34 – 8.11		6.25	7.13 – 8.23		.87	.23	.87	13.3°	1.42	5.16	150	26	5.5

NOTES:

1. Dimensions in inches unless otherwise specified. Weights are approximate in pounds.
2. The amount of Angular Movement is based on the maximum allowable Extension Movement from Neutral. Angular Movement can be increased, if it is in conjunction with Compression Movement. KEFLEXTM is aware that some manufacturers of similar products list ratings of 45-50°. It is noted these companies do not give any parameters to justify their rating. KEFLEXTM questions that different I>D> sizes, each with the same Compression/Extension Movement can have the same Angular Movement.
3. The maximum operating pressure is 170 PSIG, the maximum operating negative pressure is 26 inches of mercury, the minimum test pressure is 225 PSIG and the minimum burst pressure is 600 PSIG. At high temperatures, the pressure rating is reduced slightly.
4. Cover and tube elastomer is butyl, unless otherwise specified.

Temperature / Pressure Relationship

Temperature Degrees Fahrenheit	Pressure Derating Factors
	Series C
170	1.00
180	.97
190	.94
200	.91
210	.88
220	.85
225 (max.)	.83

MARINE FLEX—WIDE ARCH RUBBER EXPANSION JOINT



U.S. COAST GUARD  **APPROVED!**

Sizes • Movements • Weights • Pressures

Nominal Pipe Size I.D.	Neutral Length	Movement Capability from Neutral Position				Weights	
		Axial Compression	Axial Extension	±Lateral Deflection	±Angular Deflection	Joint/Rings	Control Rod Assembly
1"	6.0	1.2	0.6	0.6	50.4°	4.0	3.0
1-1/2"	6.0	1.2	0.6	0.6	38.1°	5.5	3.0
2"	6.0	1.4	0.7	0.6	34.2°	8.0	3.0
2-1/2"	6.0	1.4	0.7	0.6	27.6°	9.0	3.0
3"	6.0	1.4	0.7	0.6	23.0°	11.0	3.0
4"	6.0	1.4	0.7	0.6	18.8°	16.0	3.0
5"	6.0	1.4	0.7	0.6	15.2°	17.5	4.0
6"	6.0	1.4	0.7	0.6	12.8°	20.5	4.0
8"	6.0	1.4	0.7	0.6	9.7°	29.5	8.0
10"	8.0	1.6	0.8	0.8	9.1°	40.0	10.0
12"	8.0	1.6	0.8	0.5	7.6°	51.0	10.0
14"	8.0	1.6	0.8	0.8	6.5°	67.0	12.0
16"	8.0	1.6	0.8	0.8	5.7°	81.0	15.0
18"	8.0	1.6	0.8	0.8	5.1°	90.0	16.0
20"	8.0	1.6	0.8	0.8	5.7°	105.0	16.0

- Neoprene / Neoprene Cover & Tube
- Greater Expansion & Compression Than Sphere Type
- Custom Sizes Available!

CONCENTRIC REDUCER RUBBER EXPANSION JOINT—R SERIES

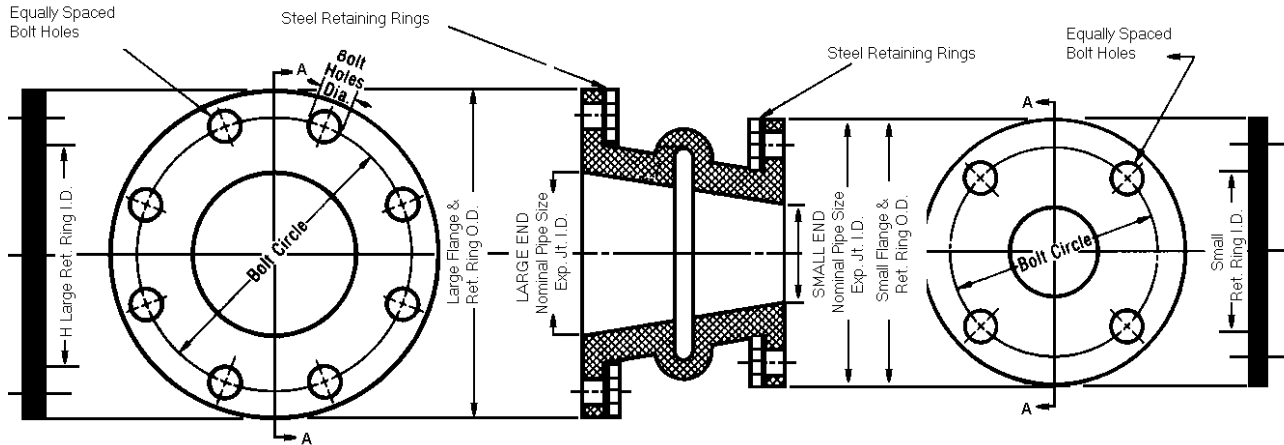

Sizes • Movements • Weights • Pressures										
Reducer Joint Size: I.D. x I. D. x Length	Movement Capability from Neutral Position						Pressure		Weights	
	Axial Compression	Axial Extension	±Lateral Deflection	±Angular Deflection	Degrees of Torsional	Thrust Factor	Positive P.S.I.G.	Negative In. of Hg.	Joint/Rings	Control Rod Assembly
3 x 2 x 6	.5	.25	.5	11.3°	3°	19.79	200	26	8.3	7.0
4 x 2 x 6	.5	.25	.5	9.5°	3°	23.92	200	26	10.8	7.1
4 x 3 x 6	.5	.25	.5	8.1°	3°	28.46	200	26	12.0	8.0
5 x 3 x 6	.5	.25	.5	7.1°	3°	33.38	190	26	13.4	10.0
5 x 4 x 6	.5	.25	.5	6.3°	3°	38.70	190	26	14.4	10.0
6 x 4 x 6	.5	.25	.5	5.7°	3°	44.41	190	26	15.9	11.0
6 x 5 x 6	.5	.25	.5	5.2°	3°	50.51	190	26	17.1	11.0
8 x 4 x 6	.75	.375	.5	7.1°	3°	63.51	190	26	22.9	19.0
8 x 5 x 6	.75	.375	.5	6.6°	3°	70.77	190	26	21.4	18.0
8 x 6 x 6	.75	.375	.5	6.1°	3°	78.42	190	26	23.0	18.0
10 x 6 x 8	.75	.375	.5	5.4°	3°	94.90	190	26	29.0	26.0
10 x 8 x 6	.75	.375	.5	4.8°	3°	112.95	190	26	29.9	25.0
12 x 8 x 6	.75	.375	.5	4.3°	3°	132.57	190	26	37.6	28.0
12 x 10 x 8	.75	.375	.5	3.9°	3°	153.76	190	26	47.8	24.0

NOTES:

1. Dimensions in inches unless otherwise specified. Weights are approximate in pounds.
2. The amount of Angular Movement is based on the maximum allowable Extension Movement from Neutral. Angular Movement can be increased, if it is in conjunction with Compression Movement.
3. Torsional Movement is expressed when the expansion joint is at Neutral.
4. To determine End Thrust: multiply Thrust Factor by operating pressure of system. This is End Thrust in P.S.I.G.
5. Pressure rating is based on 170° F. Operating Temperature. At higher temperatures, the pressure is slightly reduced. Minimum Burst Pressure is 4:1.
6. Cover and tube elastomer is butyl, unless otherwise specified.
7. Contact factory for other available size combinations or material types.

Temperature / Pressure Relationship	
Temperature Degrees Fahrenheit	Pressure Derating Factors
	Series R
170	1.00
180	.93
190	.86
200	.80
210	.73
220	.67
225 (max.)	.67

RUBBER EXPANSION JOINTS

NOTES:

The part numbering system for Rubber Expansion Joints of all types is a very simple system consisting of 6 base product specification indicators (A,B,C,D,E and F), which are explained in detail below.

ALL Rubber EJ lengths shown are standard lengths. For non-standard lengths, please consult yours manufacturer's representative or Flex-Weld, Inc. / Keflex™.

(A)	(B)	(C)	(D)	(E)
Manufacturer	Diameter (nominal)	Body Type	Material (cover/tube)	Length (nominal)

Example: For a Flex-Weld, 1-1/4" diameter, single sphere, neoprene/neoprene EJ, 6" in length, the part number would be:

(A)	(B)	(C)	(D)	(E)
F	012	S	NN	060

(A) **Manufacturer:** All Flex-Weld part numbers will begin with the letter "F" for "Flex-Weld".

(B) **Diameter (nominal):** All diameter sizes are denominated in 1/8" increments. The "012" example given indicates a nominal diameter of 1-1/4". With the exception of Reducing EJs (both concentric and eccentric), all diameters will be indicated with a 3 digit number. Concentric and Eccentric Reducing EJs are shown with a 5 digit number. The two diameter sizes are joined together into one single 5 digit number, simply eliminating the last digit of the second number. Examples are given below:

1) 3" x 2" x 6" Concentric Reducer EJ

** Diameter size is indicated with the 5 digit number "03002"

** The resulting part number would be F03002RNN060

2) 12" x 10" x 8" Concentric Reducer EJ

** Diameter size is indicated with the 5 digit number "12010"

** The resulting part number would be F12010RNN080

(C) **Body Type:** "S" example given indicates a single sphere body type. Available options shown below:

S = Single

T = Twin

R = Reducer (Concentric)

E = Reducer (Eccentric)

C = Connector (Threaded Metal)

F = Floating Flange Connector

W = Wide Arch (Marine Flex)

(D) **Material:** "NN" example given indicates Neoprene/Neoprene for both cover and tube material. Options available shown below:

BB = Butyl / Butyl

EE = EPDM / EPDM **For hot water & steam applications

ET = EPDM / Teflon **Special—Consult manufacturer (Food oriented applications)

HH = Hypalon / Hypalon

NH = Neoprene / Hypalon

NJ = Neoprene / Nitrile(FDA) **Special—Consult manufacturer (FDA controlled applications)

NN = Neoprene / Neoprene

NP = Neoprene / Nitrile

NT = Neoprene / Teflon

(E) **Length (nominal):** All length measurements are denominated in 1/8" increments, in the same manner as are diameters. Examples are given below:

002 1/4"

014 1-1/2"

030 3"

120 12"