

## VKG... Series

---

### VKG... Butterfly Valves

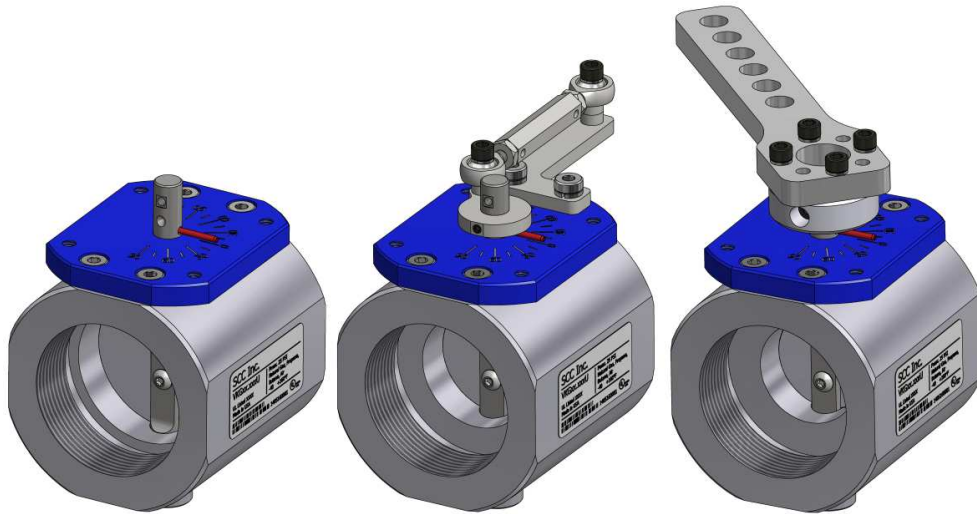

---

### Description

VKG... series threaded butterfly valves control the flow of natural gas, propane, butane, or air.

---

### Features

- Exclusive, patented technology\*
- UL approved, ½" to 4" NPT threaded
- CE approved, ½" to 3" Rp threaded
- Full, medium, or reduced port versions available to optimize pressure drop and flow control
- Shaft supported by precision bearings for repeatable performance
- Low leakage rate at full closed position without a beveled disk
- Low pressure drop at the full open position
- Corrosion-resistant for outdoor applications
- Clear position indication on a 2" laser-etched, anodized dial
- 90° clockwise or counterclockwise rotation
- Manual kits available for fixed position adjustment
- Crank arm kit available for linkage applications
- Valve actuator assemblies available (Document No. VA-1000)
- Flow in either direction

---

\*Patented under US Patent No. 9,915,352

---

## **Application**

VKG... series butterfly valves control the flow of natural gas, propane, butane, or air. Valves are positioned using either a manual kit, crank arm kit, or rotary actuator. VKG... series butterfly valves are not intended for use as shutoff valves. The valve body contains (2) identical female pipe threads for a gas tight seal with piping. Full, medium, and reduced port sizes are offered to optimize control.

---

---

## Product Part Numbers

The part number structure includes port size, pipe size, and thread type. The example part number is a VKG... series full port, 2" NPT butterfly valve.

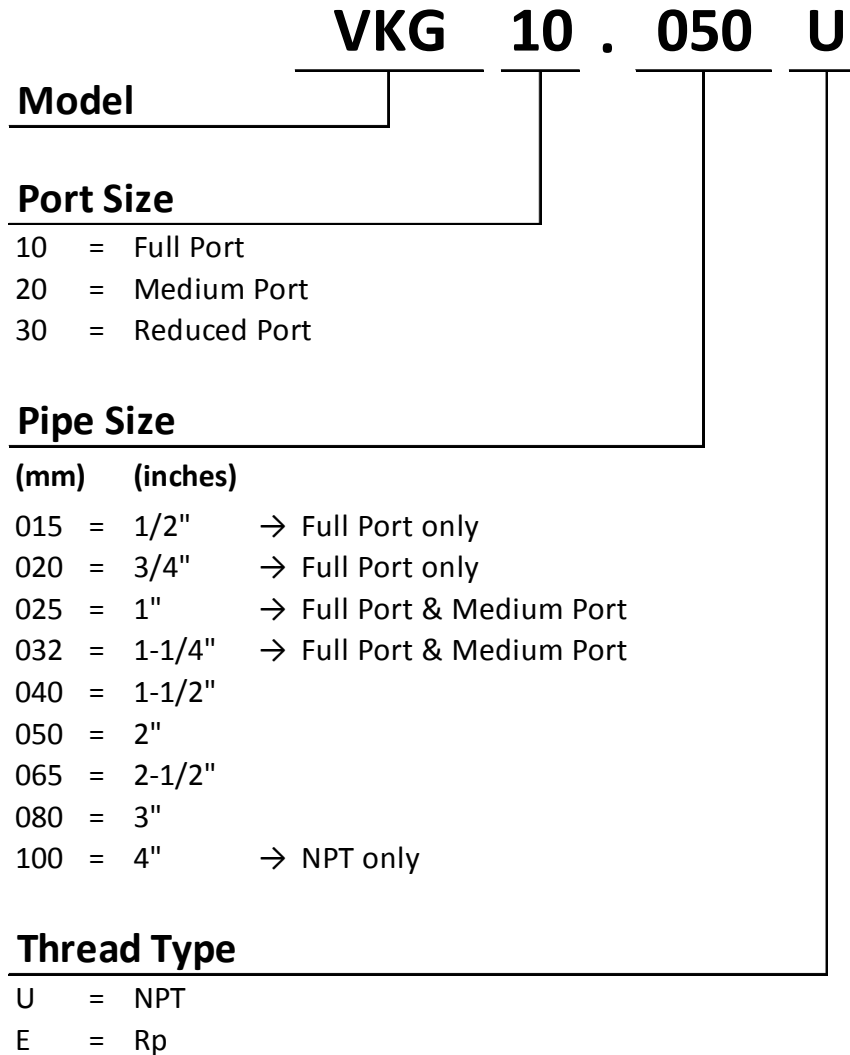

## Product Part Numbers (continued)

UL approved butterfly valve part numbers, ratings, and port diameters are tabulated below.  
The VKG...U butterfly valves are NPT thread type.

**Table 1: UL Approved Butterfly Valve Part Numbers**

Port Type	Part Number	Max Operating Pressure	Max Surge Pressure	Temperature Range	Pipe Size inch	Port Diameter inch [mm]
Full	VKG10.015U	25 psig [170 kPa]	75 psig [510 kPa]	-40 to 160°F [-40 to 70°C]	1/2	0.61 [15.5]
	VKG10.020U				3/4	0.87 [22.1]
	VKG10.025U				1	1.10 [27.9]
	VKG10.032U				1-1/4	1.46 [37.1]
	VKG10.040U				1-1/2	1.65 [41.9]
	VKG10.050U				2	2.13 [54.1]
	VKG10.065U				2-1/2	2.64 [67.1]
	VKG10.080U				3	3.23 [82.0]
	VKG10.100U	15 psig [100 kPa]	4	4.17 [105.9]		
Medium	VKG20.025U	25 psig [170 kPa]	75 psig [510 kPa]	-40 to 160°F [-40 to 70°C]	1	0.87 [22.1]
	VKG20.032U				1-1/4	1.10 [27.9]
	VKG20.040U				1-1/2	1.46 [37.1]
	VKG20.050U				2	1.65 [41.9]
	VKG20.065U				2-1/2	2.13 [54.1]
	VKG20.080U				3	2.64 [67.1]
	VKG20.100U				4	3.23 [82.0]
Reduced	VKG30.040U	25 psig [170 kPa]	75 psig [510 kPa]	-40 to 160°F [-40 to 70°C]	1-1/2	1.10 [27.9]
	VKG30.050U				2	1.46 [37.1]
	VKG30.065U				2-1/2	1.65 [41.9]
	VKG30.080U				3	2.13 [54.1]
	VKG30.100U				4	2.64 [67.1]

## Product Part Numbers (continued)

CE approved butterfly valve part numbers, ratings, and port diameters are tabulated below. The VKG...E butterfly valves are Rp thread type.

**Table 2: CE Approved Butterfly Valve Part Numbers**

Port Type	Part Number	Max Operating Pressure	Max Surge Pressure	Temperature Range	Pipe Size inch	Port Diameter inch [mm]
Full	VKG10.015E	25 psig [170 kPa]	75 psig [510 kPa]	-40 to 160°F [-40 to 70°C]	1/2	0.61 [15.5]
	VKG10.020E				3/4	0.87 [22.1]
	VKG10.025E				1	1.10 [27.9]
	VKG10.032E				1-1/4	1.46 [37.1]
	VKG10.040E				1-1/2	1.65 [41.9]
	VKG10.050E				2	2.13 [54.1]
	VKG10.065E				2-1/2	2.64 [67.1]
	VKG10.080E				3	3.23 [82.0]
Medium	VKG20.025E	25 psig [170 kPa]	75 psig [510 kPa]	-40 to 160°F [-40 to 70°C]	1	0.87 [22.1]
	VKG20.032E				1-1/4	1.10 [27.9]
	VKG20.040E				1-1/2	1.46 [37.1]
	VKG20.050E				2	1.65 [41.9]
	VKG20.065E				2-1/2	2.13 [54.1]
	VKG20.080E				3	2.64 [67.1]
Reduced	VKG30.040E	25 psig [170 kPa]	75 psig [510 kPa]	-40 to 160°F [-40 to 70°C]	1-1/2	1.10 [27.9]
	VKG30.050E				2	1.46 [37.1]
	VKG30.065E				2-1/2	1.65 [41.9]
	VKG30.080E				3	2.13 [54.1]

---

## Accessories

### VA... Valve Actuator Assemblies



Valve actuator assemblies ensure proper shaft alignment and engagement. A VKG... valve, SQM... actuator, coupling, and bracket are built, tested, and shipped as a VA... assembly. Valve actuator assemblies are available with the following Siemens actuators:

- SQM45...
- SQM33...
- SQM40/41...
- SQM5...

For additional information see Document No. VA-1000.

### AGA92.1



A manual kit with fine adjustment can be added to any VKG... butterfly valve for use as a flow restrictor. The kit allows for precision position adjustment by turning a hex coupling; (14) revolutions make a 90° stroke. Locking nuts maintain the precise position at all rated flow pressures.

### AGA92.2



A manual kit with coarse adjustment can be added to any VKG... butterfly valve.

### CA-M10R...



A crank arm kit can be added to any VKG... series butterfly valve for use with a linkage system. Three crank arm kits are available. For more information, see Document No. CPBK-8000.

## Materials

Below is a typical valve cross-section that identifies the materials used in the VKG product line.

**Table 3: VKG Parts**

Item	Description	Material
A	Valve body	Aluminum-6061
B	Seal	Buna-N
C	Shaft	Stainless Steel (300-series)
D	Dial	Aluminum-6061
E	Shim	Teflon
F	Bearing (ball)	Steel
G	Shim	Stainless Steel
H	Fastener	Steel (Zinc-plated)
I	Disk	Stainless Steel (300-series)
J	Bearing (sleeve)	Acetal
K	Bearing (thrust)	Acetal
L	Spring	Stainless Steel (17-4 PH)
M	Plug	Aluminum-6061

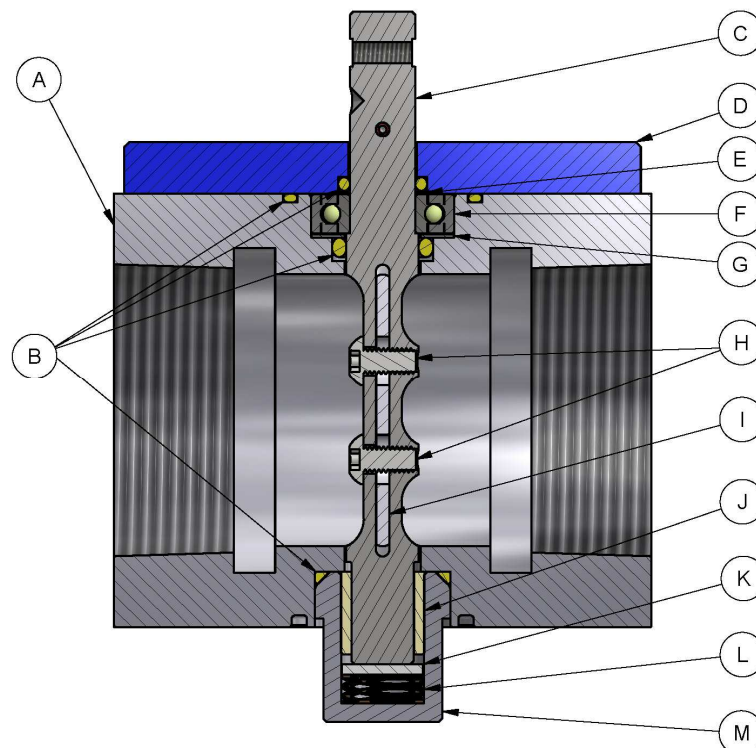

**Figure 1: Cross-section of a VKG10.040U**

## Installation

- Use suitable pipe thread sealant on all piping connections.
- **DO NOT** use the “plug” or “shaft” as a wrench grip. **ALWAYS** use a wrench on the provided valve body wrench flats when piping.
- Valve can be mounted in any orientation.
- Do not interfere with or modify the butterfly valve.
- All activities (mounting, installation, service work, etc.) must be performed by qualified staff.
- Fall or shock can adversely affect the function of these valves. Such valves must not be put into operation, even if they do not exhibit any damage.
- No special tools are required.
- Ensure the installation complies with relevant local and national codes.
- VKG... butterfly valves do not require maintenance.
- From the 0° full closed position, disk may turn in either direction to increase flow.
- Accommodates flow in either direction.

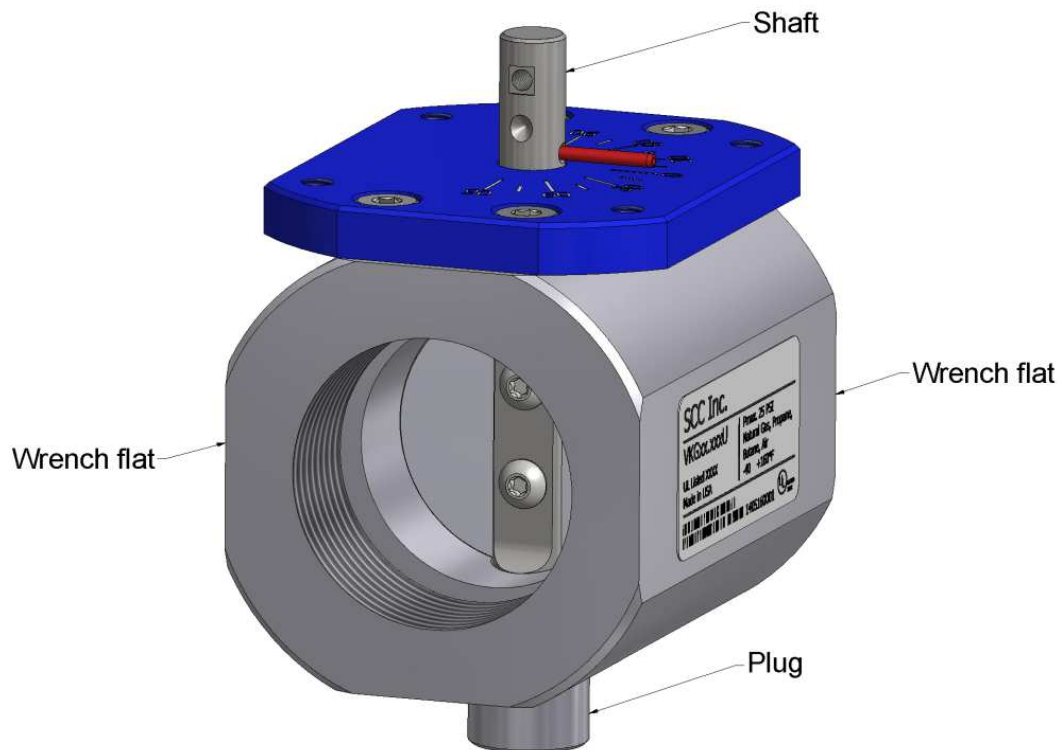

Figure 2: Isometric View of a VKG10.040U



## Flow Data

Natural gas flow (SCFH) through the valve body and the corresponding boiler horsepower (BHP) are tabulated at common differential pressures. Calculated values assume a boiler efficiency of 85% and a natural gas heating value of 1000 BTU/SCF. Valve data is sorted by ascending Cv value for ease of selection. Cv values can be utilized to calculate flow at any operating condition (see page 13).

Flow is calculated with an inlet pressure of 15" wc at a media temperature of 60°F.

Multiplier from natural gas flow (SCFH) to: Air = 0.80, Propane = 0.65, Butane = 0.57

Multiplier from boiler horsepower (BHP) to: Propane = 1.62, Butane = 1.81

**Table 4: Flow Rates of Natural Gas at Full Open Position (0.5-3" wc Differential Pressure)**

Part Number	Thread Size	Port**	Cv	0.5" wc		1" wc		1.5" wc		2" wc		3" wc	
				SCFH	BHP*	SCFH	BHP*	SCFH	BHP*	SCFH	BHP*	SCFH	BHP*
VKG10.015x	1/2	FULL	5	195	5	276	7	338	9	391	10	478	12
VKG20.025x	1	MED.	19	743	19	1,050	27	1,286	33	1,484	38	1,817	46
VKG10.020x	3/4	FULL	20	782	20	1,105	28	1,353	34	1,562	40	1,912	49
VKG30.040x	1-1/2	RED.	30	1,173	30	1,658	42	2,030	52	2,343	60	2,868	73
VKG10.025x	1	FULL	31	1,212	31	1,713	44	2,098	53	2,421	61	2,964	75
VKG20.032x	1-1/4	MED.	41	1,603	41	2,266	58	2,774	70	3,203	81	3,920	100
VKG30.050x	2	RED.	62	2,424	62	3,427	87	4,195	107	4,843	123	5,928	151
VKG10.032x	1-1/4	FULL	75	2,932	74	4,145	105	5,075	129	5,858	149	7,171	182
VKG30.065x	2-1/2	RED.	76	2,971	75	4,200	107	5,143	131	5,937	151	7,266	185
VKG20.040x	1-1/2	MED.	81	3,166	80	4,477	114	5,481	139	6,327	161	7,745	197
VKG20.050x	2	MED.	97	3,792	96	5,361	136	6,564	167	7,577	192	9,274	235
VKG10.040x	1-1/2	FULL	100	3,909	99	5,527	140	6,767	172	7,811	198	9,561	243
VKG30.080x	3	RED.	147	5,746	146	8,124	206	9,947	253	11,483	292	14,055	357
VKG20.065x	2-1/2	MED.	170	6,645	169	9,395	239	11,503	292	13,279	337	16,254	413
VKG10.050x	2	FULL	180	7,036	179	9,948	253	12,180	309	14,060	357	17,210	437
VKG30.100U	4	RED.	204	7,975	202	11,274	286	13,804	351	15,935	405	19,505	495
VKG10.065x	2-1/2	FULL	255	9,968	253	14,093	358	17,255	438	19,919	506	24,381	619
VKG20.080x	3	MED.	275	10,750	273	15,198	386	18,609	473	21,481	545	26,293	668
VKG20.100U	4	MED.	431	16,848	428	23,820	605	29,165	741	33,667	855	41,208	1,046
VKG10.080x	3	FULL	438	17,122	435	24,207	615	29,638	753	34,213	869	41,878	1,063
VKG10.100U	4	FULL	828	32,367	822	45,761	1,162	56,029	1,423	64,677	1,642	79,166	2,010

\* BHP calculated at 85% boiler efficiency

\*\* MED. = Medium RED. = Reduced

## Flow Data (continued)

Flow is calculated with an inlet pressure of 1 psig at a media temperature of 60°F.

Multiplier from natural gas flow (SCFH) to: Air = 0.80, Propane = 0.65, Butane = 0.57

Multiplier from boiler horsepower (BHP) to: Propane = 1.62, Butane = 1.81

**Table 5: Flow Rates of Natural Gas at Full Open Position (4-12" wc Differential Pressure)**

Part Number	Thread Size	Port**	Cv	4" wc		6" wc		8" wc		10" wc		12" wc	
				SCFH	BHP*	SCFH	BHP*	SCFH	BHP*	SCFH	BHP*	SCFH	BHP*
VKG10.015x	1/2	FULL	5	560	14	685	17	790	20	882	22	965	25
VKG20.025x	1	MED.	19	2,128	54	2,603	66	3,002	76	3,353	85	3,668	93
VKG10.020x	3/4	FULL	20	2,240	57	2,740	70	3,160	80	3,529	90	3,862	98
VKG30.040x	1-1/2	RED.	30	3,360	85	4,110	104	4,740	120	5,294	134	5,792	147
VKG10.025x	1	FULL	31	3,472	88	4,247	108	4,898	124	5,470	139	5,985	152
VKG20.032x	1-1/4	MED.	41	4,592	117	5,617	143	6,479	165	7,235	184	7,916	201
VKG30.050x	2	RED.	62	6,943	176	8,494	216	9,797	249	10,941	278	11,971	304
VKG10.032x	1-1/4	FULL	75	8,399	213	10,275	261	11,851	301	13,234	336	14,481	368
VKG30.065x	2-1/2	RED.	76	8,511	216	10,412	264	12,009	305	13,411	341	14,674	373
VKG20.040x	1-1/2	MED.	81	9,071	230	11,097	282	12,799	325	14,293	363	15,639	397
VKG20.050x	2	MED.	97	10,863	276	13,289	337	15,327	389	17,117	435	18,728	476
VKG10.040x	1-1/2	FULL	100	11,199	284	13,700	348	15,801	401	17,646	448	19,308	490
VKG30.080x	3	RED.	147	16,463	418	20,139	511	23,228	590	25,940	659	28,382	721
VKG20.065x	2-1/2	MED.	170	19,039	483	23,290	591	26,862	682	29,998	762	32,823	833
VKG10.050x	2	FULL	180	20,159	512	24,661	626	28,443	722	31,763	807	34,754	882
VKG30.100U	4	RED.	204	22,846	580	27,949	710	32,235	819	35,998	914	39,388	1,000
VKG10.065x	2-1/2	FULL	255	28,558	725	34,936	887	40,294	1,023	44,997	1,143	49,235	1,250
VKG20.080x	3	MED.	275	30,798	782	37,676	957	43,454	1,103	48,526	1,232	53,096	1,348
VKG20.100U	4	MED.	431	48,268	1,226	59,048	1,499	68,104	1,729	76,054	1,931	83,216	2,113
VKG10.080x	3	FULL	438	49,052	1,246	60,007	1,524	69,210	1,757	77,289	1,963	84,568	2,147
VKG10.100U	4	FULL	828	92,729	2,355	113,438	2,880	130,836	3,322	146,109	3,710	159,868	4,059

\* BHP calculated at 85% boiler efficiency

\*\* MED. = Medium RED. = Reduced

## Flow Data (continued)

Flow is calculated with an atmospheric outlet pressure at a media temperature of 60°F.

Multiplier from natural gas flow (SCFH) to: Air = 0.80, Propane = 0.65, Butane = 0.57

**Table 6: Leakage Rate (SCFH) of Natural Gas at Full Closed Position (1-16" wc Inlet Pressure)**

Part Number	Thread Size	Port	1" wc	2" wc	4" wc	8" wc	16" wc
			SCFH	SCFH	SCFH	SCFH	SCFH
VKG10.015x	1/2	FULL	7.3	13.7	25.7	39.6	61.3
VKG20.025x	1	MEDIUM	5.3	10.0	19.0	31.2	49.4
VKG10.020x	3/4	FULL	4.7	8.3	15.8	27.8	43.9
VKG30.040x	1-1/2	REDUCED	7.8	15.1	27.7	44.7	68.8
VKG10.025x	1	FULL	4.7	8.5	16.3	28.5	44.9
VKG20.032x	1-1/4	MEDIUM	6.3	12.0	23.1	36.4	57.2
VKG30.050x	2	REDUCED	9.7	20.6	35.3	57.3	87.8
VKG10.032x	1-1/4	FULL	5.3	10.4	21.0	34.9	55.8
VKG30.065x	2-1/2	REDUCED	6.5	13.8	27.8	46.8	73.0
VKG20.040x	1-1/2	MEDIUM	8.6	17.6	31.0	49.5	75.7
VKG20.050x	2	MEDIUM	9.9	20.7	35.1	57.0	87.2
VKG10.040x	1-1/2	FULL	7.4	15.2	28.3	45.7	70.0
VKG30.080x	3	REDUCED	12.3	24.9	41.2	65.7	103.6
VKG20.065x	2-1/2	MEDIUM	10.3	21.9	38.2	62.2	98.6
VKG10.050x	2	FULL	8.7	17.8	32.6	54.3	84.4
VKG30.100U	4	REDUCED	11.3	23.4	40.5	65.4	106.5
VKG10.065x	2-1/2	FULL	8.7	19.8	36.9	61.5	99.8
VKG20.080x	3	MEDIUM	9.8	22.1	39.5	65.3	106.7
VKG20.100U	4	MEDIUM	20.7	37.6	62.6	99.4	155.7
VKG10.080x	3	FULL	14.8	29.5	52.0	81.7	131.2
VKG10.100U	4	FULL	16.5	31.6	55.5	90.0	145.4

## Flow Data (continued)

**Approximate** pressure drops for a valve at a given flow rate may be determined using the chart below.

Note: When the pressure drop is more than 50% of the inlet pressure ( $P_1$ ), choked flow occurs and the chart is no longer accurate.

Flow is calculated with an inlet pressure of 1 psig at a media temperature of 60°F.

Multiplier from natural gas flow (SCFH) to: Air = 0.80, Propane = 0.65, Butane = 0.57

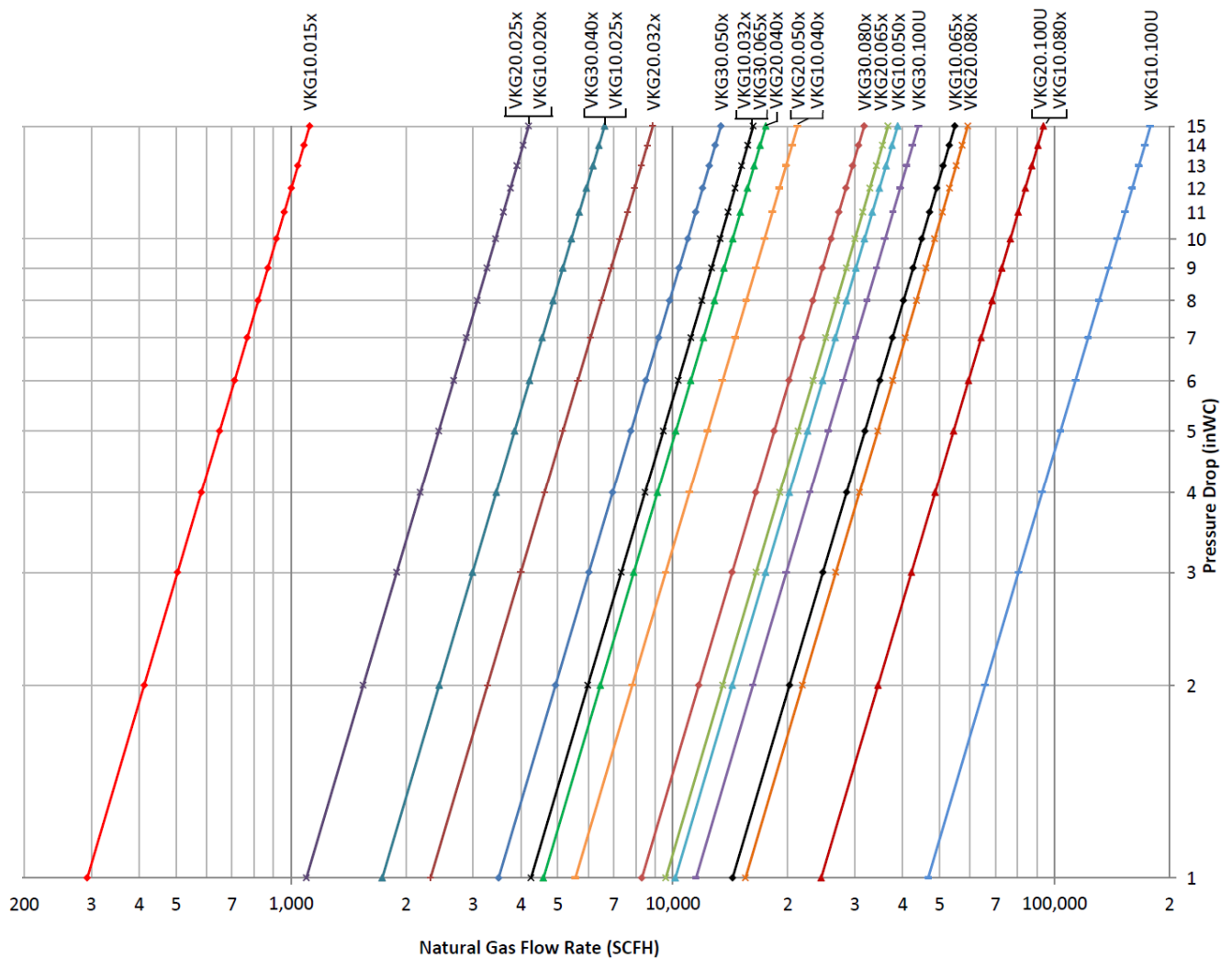

**Figure 3: Logarithmic Scale Plot of VKG Natural Gas Flow Capacities for Full Open Position**

## Flow Data (continued)

Flow rate (SCFH) through the valve body at the full open position can be estimated using the equation below and the  $C_v$  values from Table 4.

$$Q = 1360 \times C_v \times \left( \sqrt{\frac{P_1 + P_2}{GT_f}} \right) \times \left( \sqrt{\frac{P_1 - P_2}{2}} \right)$$

...where...

$C_v$  = Flow coefficient (see Table 4)

G = Specific gravity of gas (see Table 7)

$P_1$  = Absolute inlet pressure in PSIA (PSIG + 14.7)

$P_2$  = Absolute outlet pressure in PSIA (PSIG + 14.7)

Q = Flow rate in SCFH

$T_f$  = Media temperature in degrees Rankine ( $^{\circ}\text{F} + 460$ )

Boiler horsepower is calculated using the equation below.

$$\text{Boiler hp} = Q \times (\text{HHV}) \times \eta \times \frac{1 \text{ Boiler hp}}{33,475 \text{ BTU/HR}}$$

...where...

Q = Flow rate (SCFH)

HHV = Higher Heating Value (BTU/SCF)

$\eta$  = Boiler efficiency (assume: 85% efficiency or 0.85)

**Table 7: Constants for Boiler Horsepower Calculations by Applicable Gases**

Type of Gas	Specific Gravity	Higher Heating Value (Btu/SCF)
Natural Gas	0.64	1000
Air	1.00	-
Propane	1.52	2500
Butane	2.00	3200

---

## Actuator Torque

Torque requirements for the 4" full port valve (VKG10.100U) are tabulated at various differential pressures to ensure proper actuator selection. The VKG10.100U valve requires more torque than all other models. Maximum torque occurs at approximately the 60 degree position at high flow rates. A maximum of 20 in-lbs is required to modulate any VKG... valve.

**Table 8: Maximum Torque Values at Various Pressure Differentials**

Differential Pressure		Torque	
psi	kPa	in-lbs	N-m
6	41	10	1.13
10	69	15	1.69
15	100	20	2.26

## Dimensions

Dimensions in inches; millimeters in brackets

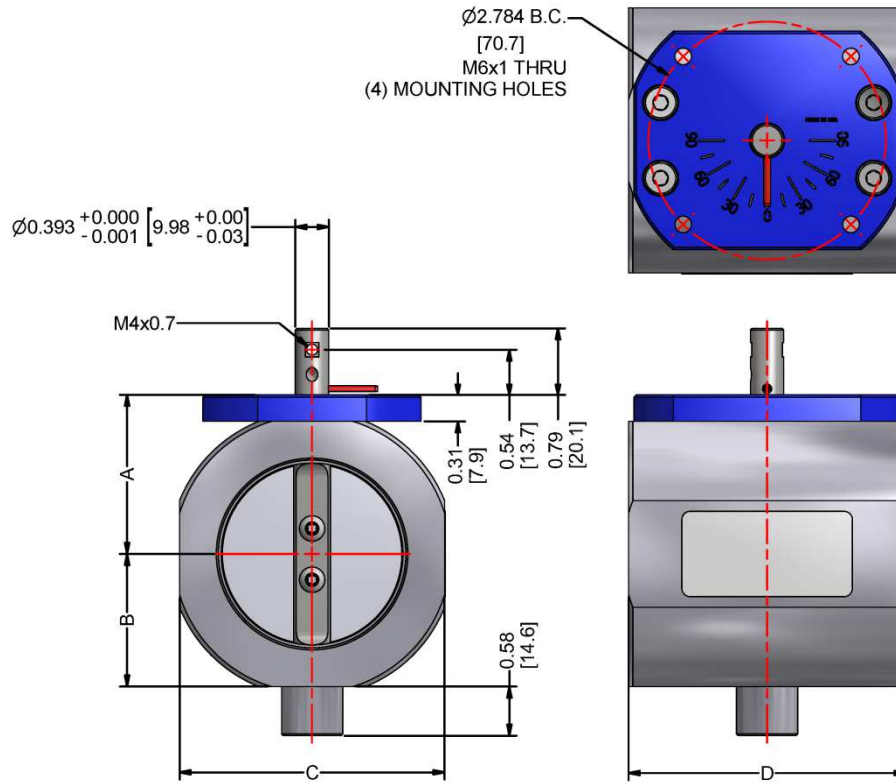

Figure 4: Dimensions of the VKG... Valve Shown on a VKG10.050U

Table 9: VKG... Valve Dimensions

Part Number	A	B	C	D
VKGxx.015x	1.35 [34]	1.04 [26]	2.08 [53]	3.25 [83]
VKGxx.020x	1.35 [34]	1.04 [26]	2.08 [53]	3.25 [83]
VKGxx.025x	1.35 [34]	1.04 [26]	2.08 [53]	3.25 [83]
VKGxx.032x	1.53 [39]	1.22 [31]	2.44 [62]	3.25 [83]
VKGxx.040x	1.63 [41]	1.31 [33]	2.63 [67]	3.25 [83]
VKGxx.050x	1.87 [47]	1.55 [39]	3.11 [79]	3.25 [83]
VKGxx.065x	2.18 [55]	1.87 [47]	3.74 [95]	4.38 [111]
VKGxx.080x	2.44 [62]	2.13 [54]	4.26 [108]	4.38 [111]
VKGxx.100U	2.96 [75]	2.64 [67]	5.28 [134]	5.00 [127]

## Dimensions (continued)

Dimensions in inches; millimeters in brackets

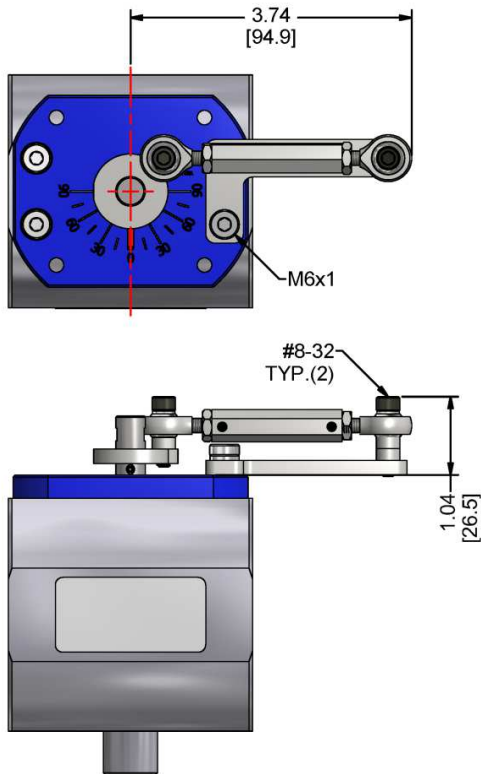

**Figure 5: Dimensions of the AGA92.1  
Manual Kit**

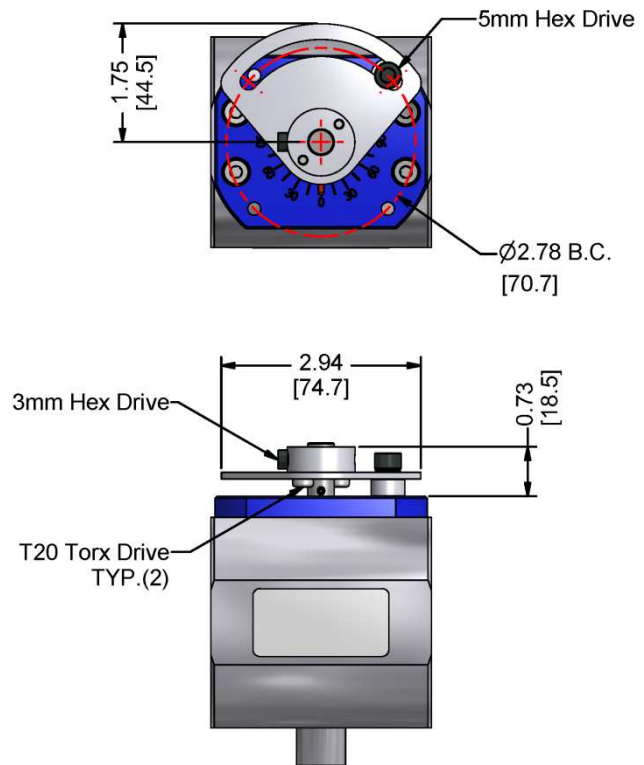

**Figure 6: Dimensions of the AGA92.2  
Manual Kit**



## Dimensions (continued)

Dimensions in inches; millimeters in brackets

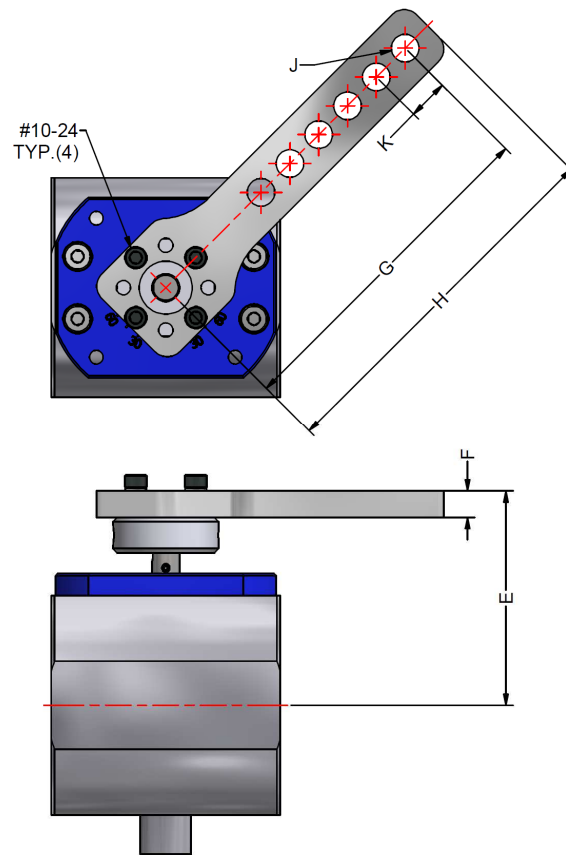

Figure 7: Dimensions of the CA-M10R... Linkage Kits

Table 10: CA-M10R... Linkage Kit Dimensions

Part Number	E	F	G	H	J	K
CA-M10R-1	3.03 [77]	0.38 [10]	4.80 [122]	5.25 [133]	0.39 [10] x6	0.58 [15]
CA-M10R-2	2.79 [71]	0.14 [3]	4.50 [114]	5.00 [127]	0.26 [7] x9	0.38 [10]
CA-M10R-3	2.79 [71]	0.14 [3]	4.50 [114]	5.00 [127]	0.26 [7] slot	3.00 [76] slot

Information in this publication is based on current specifications. The company reserves the right to make changes in specifications and models as design improvements are introduced. Product or company names mentioned herein may be the trademarks of their respective owners. © 2018 SCC Inc.