

**IMPORTANT INFORMATION:**

This product is not compatible with fuel blends containing more than 5% biodiesel.

**INSTALLATION:** This product must be installed, adjusted and started only by a qualified and licensed technician and done so in accordance with all appropriate local and national codes and ordinances, such as National Fire Protection Standard for Liquid Fuel Equipment, NFPA 31, CSA B139-M91, etc.

**WARNING: Inlet and Return Line Pressures**

MUST NOT EXCEED 10 PSI (boost and burner pumps), or seal damage can result! NFPA 31 further limits them to 3 PSI Max.

**WARNING: Check Valves with Fuel Oil Heating Equipment**

For a boost pump or a burner pump (used with or w/o a boost pump), do not use a check valve in the inlet line of a 1-pipe system, or in the return line of a 2-pipe system. Check valve flow restriction in a return line can elevate pressures and damage fuel unit seals. Dangerous thermal expansion of oil trapped by an inlet line check valve can create extreme pressures that damage fuel unit seals, fittings, filters, gages and other components. A properly installed vacuum safety valve, such as Suntec PRV-38, having accumulator effect and pressure relief to tank is acceptable in the inlet line.

**GENERAL INFORMATION**

1. A Suntec Boost Pump, used with a Pressure Switch, provides a simple low cost means to supply No.2 & Lighter Fuel Oil to one or more remote heaters. Locate the boost pump close to the supply tank for low cost plumbing and wiring, and for good performance; the boost pump should PUSH the oil to the heaters, not PULL it! Only low voltage wiring is needed between each burner and the boost pump motor relay.
2. Standard 10-20 PSI models will push the oil up 35 feet. Higher pressure models will push the oil to higher elevations.

**BOOST PUMP COMPONENTS**

**PUMP:** Most boost pumps have a 10-20 PSI pressure range. See the chart for details.

**MOTOR:** Special 115-1-60 motor with pump mount cavity; see details in chart.

**COUPLING:** Direct drive, flexible, oil resistant coupling for long life and quiet operation.

**PRESSURE SWITCH:**

Suntec P/N 128117 can be used with a low voltage relay to control the boost pump motor. The normally open 40VA pressure switch has a 1/8 NPTF male thread to fit in the burner pump gage port, and a 35-75 PSI adjustable close pressure (factory set at 50 PSI). One is needed for each burner. See separate instructions with switch.

**1-PIPE BOOST PUMP HOOK-UP – NO RETURN LINE:**

This hook-up is not commonly used with boost pumps. See pump installation literature for plumbing instructions and inlet line sizing. See "PRESSURE SIDE" section of this literature for discharge line sizing.

**2-PIPE BOOST PUMP HOOK-UP – INLET AND RETURN LINE:**

This self-priming hook-up is most common for boost pumps. See pump installation literature for plumbing instructions and inlet line sizing. See "PRESSURE SIDE" section of this literature for discharge line sizing.

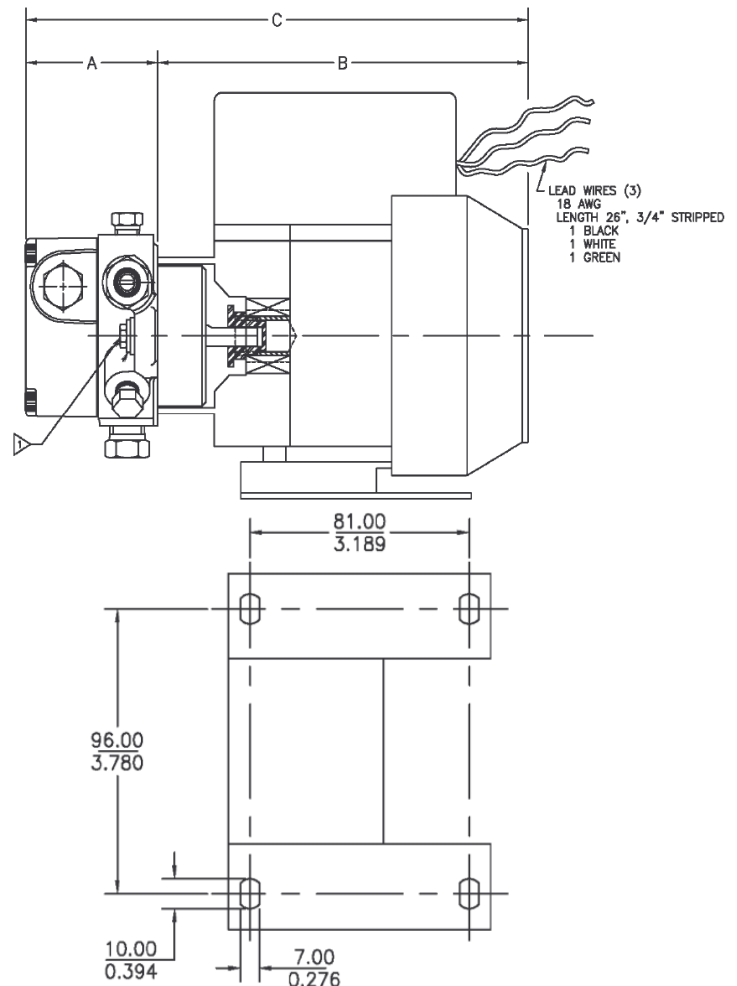

BOOST PUMP MODEL	FUEL UNIT MODEL	MOTOR-COUPLING ASSY	PRESSURE RANGE PSI	DELIVERY (GPH)		FUEL UNIT CUT-OFF	"A" FUEL UNIT LENGTH (IN.)	"B" MOTOR LENGTH (IN.)	"C" QA LENGTH REF. (IN.)
				O MIN. PRES.	O MAX. PRES.				
BA-7116CM	A2VA-7116	134503	100-200	3	2	YES	2.250	6.200	8.450
BA-7747CM#	A2RA-7747	134503	5-15	2.5	2.5	NO	2.250	6.200	8.450
BB-1016CM	B2TA-8260	134509	100-200	23	15	YES	2.750	6.615	9.365
BB-1020CM	B2VA-8241	134503	10-20	20	20	YES	2.750	6.200	8.950
BB-1220CM	B2TA-8245	134509	200-300	23	16	YES	2.750	6.615	9.365

\* - Motor-coupling 134503: 3450 RPM, 1/6 HP, 120-1-60, 1.8 AMPS.  
 Motor-coupling 134509: 3450 RPM, 1/4 HP, 120-1-60, 2.7 AMPS.  
 # - Waste oil unit for replacement of exact same model only!  
 Special plumbing required.

**PRESSURE SIDE:** Following are some options for plumbing the discharge or manifold side of the boost pump.

**LOOP SYSTEM:** See the schematic. A slight positive pressure meeting all codes is maintained in the manifold line by the use of a two foot riser after the last heater in the system.

1. The manifold line is placed above the burners.
2. **Max. Inlet and Return Line Pressure:** See **WARNING** enclosed!
3. **Maximum Manifold Line Length (10-20 psi pump spring):**

Boost pump	1/2" Tube	1/2" Pipe	3/4" Pipe
BB-1020	300'	500'	2500'
BJ-1030	175'	300'	1800'
BJ-1070	50'	100'	600'

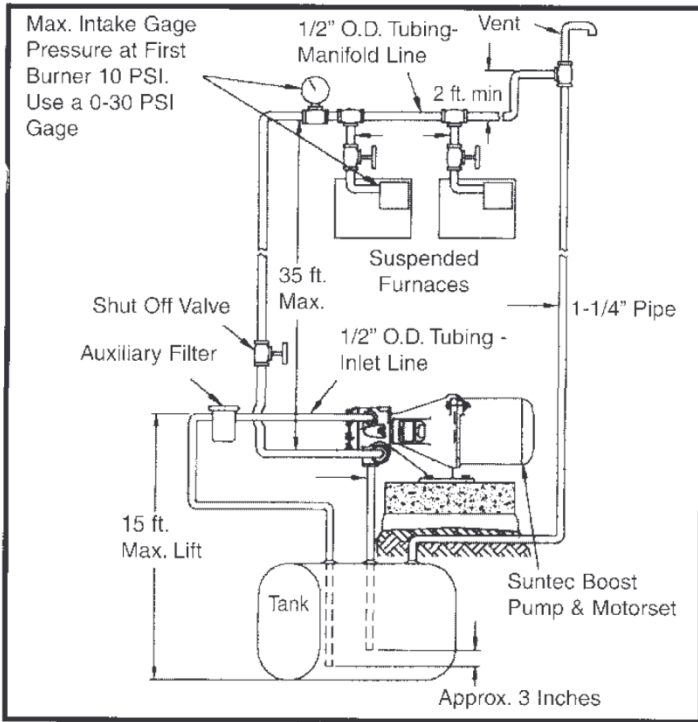

Loop System Installation

**AUXILIARY TANK:** See the schematic. This installation is a form of the loop system and is subject to the same installation requirements. Additionally, it is necessary to comply with local ordinances governing auxiliary tanks. The auxiliary tank acts as an accumulator, eliminating line surges between the boost pump and the burners.

**PRESSURIZED SYSTEM:** See the schematic. This installation can be used where space precludes using the loop system.

1. **Max. Inlet & Return Line Pressure:** See **WARNING** enclosed!
2. Each remote heater must use a **PRV-38 oil safety valve** in its inlet side between the heater and the manifold line.
3. **Max. Manifold Line Length:** same as for loop system.
4. **Never use check valves!** See **WARNING** enclosed.

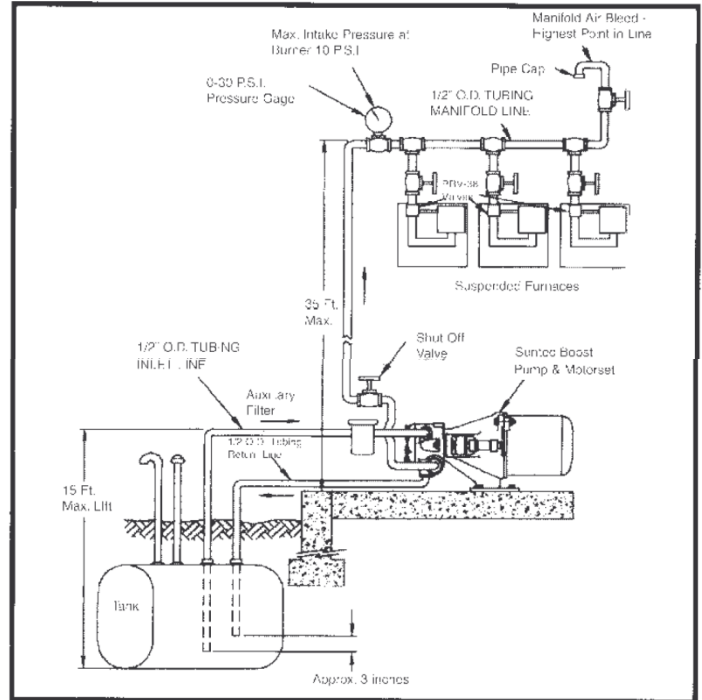

Pressurized System Installation

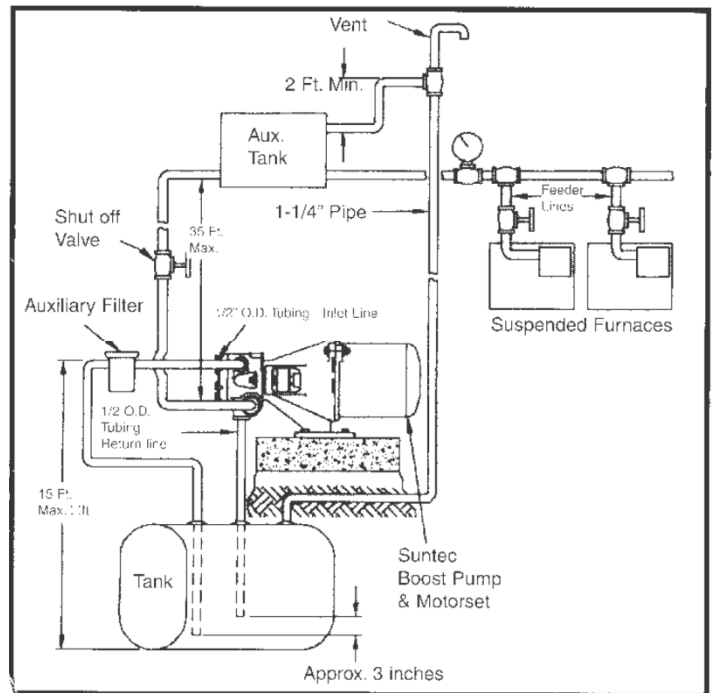

Auxiliary Tank Installation

## WIRING INSTRUCTIONS:

- A. **CONSTANT OPERATION:** See the schematic showing a simple ON/OFF voltage switch in the power line.

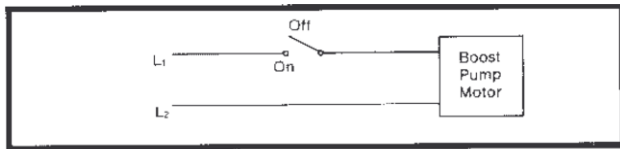

Wiring for Constant Operation

- B. **INTERMITTENT OPERATION:** See "PRESSURE SWITCH"

## START-UP AND SERVICING:

### A. START-UP:

1. Start the boost pump manually.
2. With the remote heaters off, set the boost pump so the pressure into the first burner pump is as specified in the "IMPORTANT INFORMATION" section.
3. Run the boost pump several minutes to pressurize the system. Then loosen the pipe cap and bleed air from the manifold line. Re-tighten the cap.
4. Bleed air from the first burner pump by loosening an unused inlet plug. Progress downstream, bleeding each of the other burner pumps.

### B. SERVICE:

1. Periodically check for fuel tank water to prevent boost pump corrosion.
2. At least annually, change the strainer in the boost pump and the burner pumps, and change the external filter element.
3. Periodically check all electrical connections.
4. Never let the manifold pressure exceed the setting specified in the "IMPORTANT INFORMATION" section.

## TROUBLESHOOTING:

- A. **Boost pump doesn't run:** Check electrical connections and power supply. Check for discharge and return line blockages.
- B. **Boost pump runs, but doesn't supply oil:** Measure the inlet vacuum. If high, check the inlet line, filter and valves for blockages. Ensure the bypass plug is properly installed. Ensure the inlet line has no air leaks.
- C. **Boost pump supplies oil, but burners do not fire:** Check to be sure boost pump capacity exceeds burner requirement. Check to be sure boost pump pressure rating exceeds the head requirement. In a loop system, check to be sure oil is passing through the stand pipe or riser.
- D. **Burner pump seal leaks:** Recheck the burner pump inlet pressure as specified in "START-UP" section.