

LAARS® PENNANT

High Efficiency
Commercial Boiler and
Volume Water Heaters



Built-In Versatility

- LAARS LINC™ Intuitive Control System
- 85% Thermal Efficiency
- 500 to 2,000 MBH
- Stage Firing: Up to 4:1
- Cascade with Auto Redundancy
- Vent from Top or Back
- Indoor/Outdoor Construction

PENNANT

FIELD PROVEN RELIABILITY *PLUS* INTUITIVE CONTROLS



Space saving, rack mounted Pennant boilers with Laars Linc intuitive control system.

For more than 70 years, the LAARS brand has stood for quality, reliability, and innovation in heating system design. Laars builds on that tradition with the addition of the Laars Linc intuitive control system to the reliable Pennant line of fan-assisted, modular boilers and water heaters.

Pennant boilers rank among the industry's most versatile commercial systems for hydronic and hot water applications.

- Available as a boiler or volume water heater
- 7 sizes from 500 to 2000 MBH
- Natural or LP gas operation
- AHRI certified thermal efficiency levels of 85%
- Pennant systems are also among the "greenest" in the industry with NOx emissions below 10 ppm

All Pennant models use lightweight insulation, glass-lined cast iron or bronze headers, and non-ferrous waterways. The 10 tube heat exchanger design uses finned copper or cupro-nickel tubing for the quickest and most efficient heat transfer.

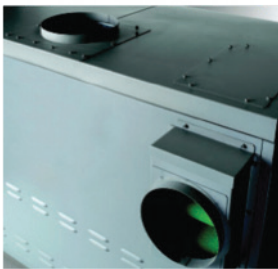

Top or rear vent and combustion air connections

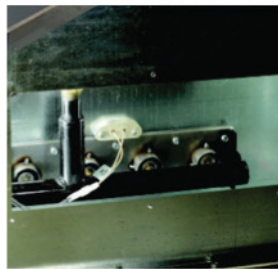

Easy Access to Ignitor.



Field proven ASME heat exchanger with copper finned tubes and glass lined cast iron headers.

Easy to Install

Pennant boilers and water heaters feature convenient, modular construction that separates the burner trays, gas train, and blower assembly making Pennant units easy to install and maintain. Water connection may be reversed to accommodate left or right side piping.

The sealed combustion system is fan-assisted and uses either ambient room air, or air from the outside ducted directly to the unit. This allows the Pennant to be vented as a Category I or Category III appliance. Category I fan assisted appliances allow for smaller diameter vents than natural draft units, but can still be vented with standard B-vent.

Vent and combustion air connections can be located on the top or the back of the unit, in any combination, and every unit has a long-lasting, washable air filter to keep the burner clean, ensuring its long life.

Easy to Maintain

Ongoing maintenance of Pennant is easy. The burner assembly features modular burner trays to ensure perfect alignment of orifices and burners, gas manifolds mount on the burner flange, and the burner flanges seal to the air box.

In addition, the entire gas train can be easily removed and the heat exchanger simply lifts out from the top or front of the unit. The air filter is a breeze to clean... just wash it with soap and water.

Controls are also service-friendly with clean and simple wiring and are readily accessible from the front of the Pennant.

All models have a convenient front-access panel with an easy to read large color touch screen display that clearly spells out any issues in full text, not complicated codes.

Easy to Use

All Pennant boilers and volume water heaters come with the Laars Linc intuitive control system that makes setup, trouble shooting and diagnostics a breeze!

Units are built to operate effectively at up to 10,000 feet, in harsh environments from -40° to +140°F, and to withstand thermal shock down to 30°F.

Pennant boilers can be used with up to a 50:50 glycol to water mix and waterways can operate in water with a hardness up to 17 gpg.

Pennant units feature compliant end walls to accommodate thermal expansion.

The Pennant is the easy choice. With Pennant's high efficiency, operating costs are minimized. Pennant's performance and low maintenance deliver the savings!

LAARS LINC™ TOUCH SCREEN CONTROLS

THE INTUITIVE CONTROL SYSTEM

Laars Linc controls are a step beyond smart, they're intuitive.

Powerful control logic is easily managed via icon driven, touch screen technology. The result is an intuitive to use control system with the intelligence to manage installations from the simple to the complex.

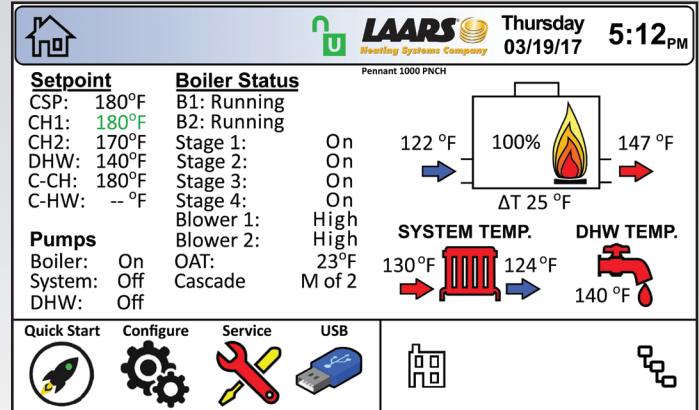

Laars Linc home screen.

Advanced Ease of Use Functionality Sets the Laars Linc Control Apart:

- **Home Screen Boiler Status:** The home screen shows the operational status of the boiler; all set points, status of each pump, status of each stage, and boiler run status.
- **Easy to Use Icon Menu:** All parameters are accessible through the Laars Linc intuitive to use icon menu structure.
- **Quick Start Configurator:** Simply touch the "Quick Start" icon on the home screen to access the most commonly-used parameters for systems that don't require advanced set up.
- **Intelligent Redundancy:** Laars Linc cascade logic includes a built-in redundancy; via either a lag unit's internal setpoint, or a configurable redundant leader. A bank of boilers will continue to operate even if the master control goes down, keeping buildings warm and hot water flowing!
- **Auto Configuring Cascade:** Up to 8 Pennant boilers can be automatically configured by simply connecting the controls and selecting the master boiler. The intelligence of Laars Linc takes over to auto configure the remaining follower boilers. No need to register each follower!
- **Laars Linc Control to Display Handshake:** If for any reason a display or control board needs to be replaced, the parameter set is automatically transferred from the remaining display or control board to the replaced component. Parameters are stored on both the display and control to auto populate either one!
- **USB Data Connection:** The USB connection allows for easy transfer of parameter sets from one boiler to another and for the boiler's history data to be transferred to a USB memory device.
- **Multiple Pump Control:** System pump, boiler pump and domestic water pump operation, each with time delay.

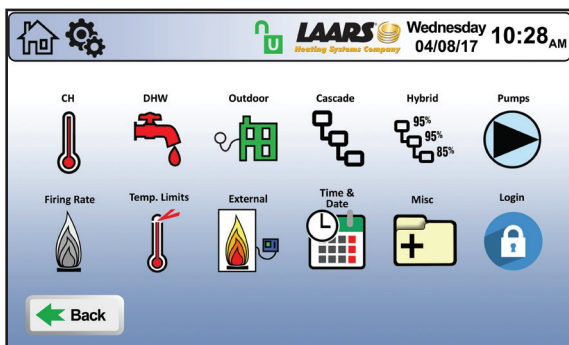

Configure Screen:

Intuitive to use, easy to understand icon menu structure. All functions only a few touches away.

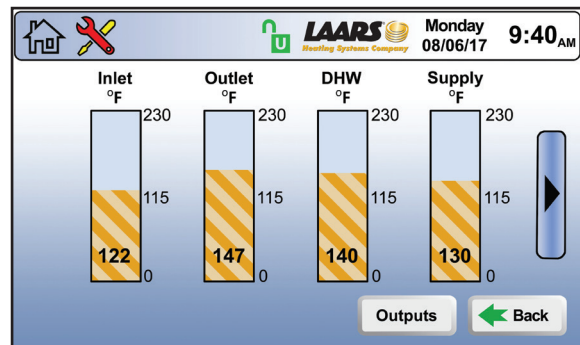

Inputs and Outputs:

Easily monitor multiple input and output readings when in service mode.

STANDARD FEATURES

- ASME 160 psi working pressure heat exchanger (125psi on VWH)
- ASME "H" stamp (HLW Option on VWH)
- Electronic staging & ignition control with LCD touchscreen
- Cascades up to 8 boilers with redundancy options
- Multiple pump control (system, boiler and indirect water heater), each with time delay
- BACnet MSTP and Modbus (optional BACnet IP, Metasys, or LonWorks)
- Accepts external 0-10VDC or 4-20mA for remote control of temperature or stages
- Displays messages in clear text form
- Complete diagnostics for analog and digital inputs
- Password protected parameters
- Quick start configuration
- Hot surface ignition
- 24V control system
- On/off toggle switch
- 115/24VAC transformer
- Boiler, system, DHW, and outdoor temperature sensors (DHW Sensor on VWH)
- Manual reset high limit
- Automatic reset high limit
- Dry run and alarm contacts
- Anti-frost mode
- Anti-short-cycle mode
- Pump, mounted and wired (when ordered as pump-mounted unit)
- Flanged water connections
- Glass-lined headers
- External header gaskets
- 75 psi (517kPa) ASME rated pressure relief valve (125 psi 861kPa rating for VWH)
- Water Flow switch
- Temperature/pressure gauge
- Multiple operating gas valve/pressure regulators
- Manual "A" gas valve
- Multiple removable burner trays
- Stainless steel burners
- Built-in draft fan for Category I or III vent systems
- Intake air filter
- Air pressure switch
- Burner site glass

OPTIONAL LOW TEMPERATURE CONFIGURATION

Prevent damaging condensing operation caused by cold return water with a factory designed, tested and mounted three-way valve and an automatic by-pass system.

This reliable system works in concert with the boiler operating control to maintain a minimum boiler return temperature of 120°F(49°C).

Heat exchanger condensation is prevented, ensuring a long boiler life, even when there are rapid swings in the return water temperature from the system. The Pennant LT can handle return water temperatures as low as 70°F (21°C) — making it the perfect unit for your low temperature boiler and water heater systems.

All low temp Pennant models have on/off firing and are supplied with a wired and mounted pump.



Pennant with Low Temp mixing system

IDEALLY SUITED FOR

- Back-up to heat pump systems
- Radiant floor heating
- Snow melting systems
- Process water heating
- Low-temp baseboard systems

TECHNICAL DATA

Pennant Sizing Data

Size	Input MBH	Input kW	Output MBH	Output kW	Firing Rate	Boiler (PNCH) Combustion Efficiency (%)	Boiler (PNCH) Thermal Efficiency (%)	Water Heater (PNCV) Thermal Efficiency (%)	Gas Connection inches	Water Connection inches	Approx. Shipping Weight ⁹	
											lbs.	kg
500	500	147	425	125	2-Stage	85.0	85.0	85	1¼	2	640	290
750	750	220	638	187	2-Stage	85.0	85.0	85	1¼	2	735	333
1000	999	293	849	249	3-Stage	85.0	85.0	85	1½	2½	830	376
1250	1,250	366	1,064	312	4-Stage	85.1	85.2	85	2	2½	925	420
1500	1,500	440	1,266	371	4-Stage	85.1	85.2	85	2	2½	1020	463
1750	1,750	513	1,489	436	4-Stage	85.1	85.2	85	2	2½	1115	506
PNCH2000	1,999	586	1,701	498	4-Stage	85.1	85.2	85	2	2½	1210	549
PNCV2000	2,000	586	1,701	498	4-Stage	85.1	85.2	85	2	2½	1210	549

1. Low Temp Pennants have 1-stage ON/OFF firing
2. Input and output must be derated 4% per 1000 feet above sea level when installed above 2000 feet altitude.
3. Add 75 to 200 lbs (34 to 91 kg) depending on size, for pump mounted units.

Water Flow Requirements Temperature Rise in Degrees

Size	20°F		11°C		25°F		14°C		30°F		17°C		35°F		19°C	
	Flow GPM	H/L Feet	Flow lpm	H/L m	Flow GPM	H/L Feet	Flow lpm	H/L m	Flow GPM	H/L Feet	Flow lpm	H/L m	Flow GPM	H/L Feet	Flow lpm	H/L m
500	43	1.7	161	0.5	34	1.1	129	0.3	28	0.9	107	0.3	24	0.7	92	0.2
750	64	3.3	242	1.0	51	2.3	193	0.7	43	1.7	161	0.5	36	1.2	138	0.4
1000	85	5.0	321	1.5	68	3.6	257	1.1	57	3.1	214	0.9	49	2.2	184	0.7
1250	106	8.1	402	2.5	85	6.1	322	1.9	71	4.7	268	1.4	61	3.4	230	1.0
1500	128	10.0	483	3.0	102	7.2	386	2.2	85	5.5	322	1.7	73	4.2	276	1.3
1750	N/R	N/R	N/R	N/R	119	10.5	451	3.2	99	8.4	375	2.6	85	5.8	322	1.8
2000	N/R	N/R	N/R	N/R	136	12.5	515	3.8	113	10.4	429	3.2	97	8.3	368	2.5

Headloss/Water Heater Headloss shown is for Pennant heat exchanger only

Size	HARD WATER				NORMAL WATER				SOFT WATER			
	Flow GPM	H/L Feet	Flow lpm	H/L m	Flow GPM	H/L Feet	Flow lpm	H/L m	Flow GPM	H/L Feet	Flow lpm	H/L m
500	90	3.5	341	1.1	68	2.3	257	0.7	45	1.8	170	0.5
750	90	6.0	341	1.8	68	3.0	257	0.9	45	2.1	170	0.6
1000	90	6.1	341	1.9	68	3.6	257	1.1	45	2.3	170	0.7
1250	90	6.3	341	1.9	68	3.8	257	1.2	68	3.8	257	1.2
1500	90	6.5	341	2.0	68	3.9	257	1.2	68	3.9	257	1.2
1750	90	6.7	341	2.0	68	4.0	257	1.2	68	4.0	257	1.2
2000	112	10.0	424	3.0	112	10.0	424	3.0	112	10.0	424	3.0

Clearances

Appliance Surface	Required to Combustible Material		Suggested Service Access	
Left Side	1	2.5	24	61
Right Side	1	2.5	24	61
Top	1	2.5	12	30
Back*	1	2.5	12	30
Front	1	2.5	36	91
Vent	Per venting system supplier's instructions			
*When vent or air is connected to the back, 36" (91cm) is suggested.				

Recovery Data/Water Heater Temperature Rises in Degrees

Size	40°F gph	22°C L/h	50°F gph	28°C L/h	60°F gph	33°C L/h	70°F gph	39°C L/h	80°F gph	44°C L/h	90°F gph	50°C L/h	100°F gph	56°C L/h	120°F gph	67°C L/h	140°F gph	78°C L/h
500	1276	4821	1020	3857	850	3214	729	2755	638	2411	567	2143	510	1929	425	1607	364	1378
750	1915	7238	1532	5790	1277	4825	1094	4136	957	3619	851	3217	766	2895	638	2413	547	2068
1000	2548	9632	2038	7705	1699	6421	1456	5504	1274	4816	1132	4281	1019	3853	849	3211	728	2752
1250	3189	12054	2551	9643	2126	8036	1822	6888	1594	6027	1417	5357	1276	4821	1063	4018	911	3444
1500	3827	14464	3061	11571	2551	9643	2187	8265	1913	7232	1701	6429	1531	5786	1276	4821	1093	4133
1750	4464	16875	3571	13500	2976	11250	2551	9643	2232	8438	1984	7500	1786	6750	1488	5625	1276	4821
2000	5099	19274	4079	15419	3399	12850	2914	11014	2550	9637	2266	8566	2040	7710	1700	6425	1457	5507

NOTE: gph = gallons per hour, L/h = Liters per hour.

DIMENSIONS

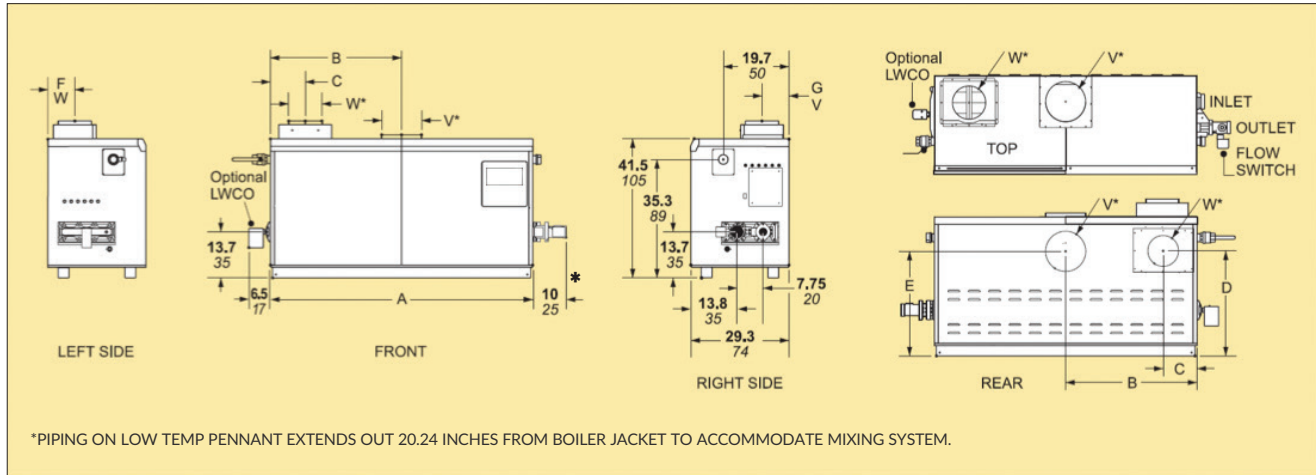

Size	A		B		C		D		E		F		G		Air Conn. W*		Vent Conn. V*		Horiz. Vent	
	in	cm	in	cm	in	cm	in	cm	in	cm	in	cm	in	cm	in	cm	in	cm	in	cm
500	33 ¹ / ₂	85	15 ³ / ₄	40	5 ³ / ₄	15	29 ³ / ₄	76	33 ³ / ₄	86	7 ³ / ₄	20	8 ³ / ₄	22	6	15	8	20	6	15
750	45 ¹ / ₂	116	21 ³ / ₄	55	5 ³ / ₄	15	29 ³ / ₄	76	33 ³ / ₄	86	7 ³ / ₄	20	8 ³ / ₄	22	8	20	10	25	8	20
1000	57 ¹ / ₂	146	28 ³ / ₄	73	5 ³ / ₄	15	29 ³ / ₄	76	33 ³ / ₄	86	7 ³ / ₄	20	7	18	8	20	10	25	8	20
1250	68	172	34	86	10 ¹ / ₈	26	30 ³ / ₄	78	31 ¹ / ₈	79	8 ³ / ₄	22	8 ³ / ₄	22	12	30	12	30	10	25
1500	78 ¹ / ₂	199	39 ³ / ₄	101	10 ¹ / ₈	26	30 ³ / ₄	78	31 ¹ / ₈	79	8 ³ / ₄	22	8 ³ / ₄	22	12	30	12	30	10	25
1750	89	226	44 ¹ / ₂	113	10 ¹ / ₈	26	30 ³ / ₄	78	31 ¹ / ₈	79	8 ³ / ₄	22	8 ³ / ₄	22	12	30	14	36	12	30
2000	99 ¹ / ₂	253	49 ³ / ₄	126	10 ¹ / ₈	26	30 ³ / ₄	78	31 ¹ / ₈	79	8 ³ / ₄	22	8 ³ / ₄	22	12	30	14	36	12	30

NOTE: *Air and vent connections may be on top or back of the Pennant, and they are field convertible. Dimensions shown in inches cm. Dimensions are nominal.



LAARS®

Heating Systems Company

A subsidiary of **BRADFORD WHITE** Corporation

Customer Service and Product Support: 800.900.9276 • Fax 800.559.1583

Headquarters: 20 Industrial Way, Rochester, NH, USA 03867 • 603.335.6300 • Fax 603.335.3355

9 Brigden Gate, Halton Hills, Ontario, Canada L7G 0A3 • 905.203.0600 • Fax: 905.636.0666

www.Laars.com