

Operator: Save these instructions for future use!

FAILURE TO READ AND FOLLOW ALL INSTRUCTIONS CAREFULLY BEFORE INSTALLING OR OPERATING THIS CONTROL COULD CAUSE PERSONAL INJURY AND/OR PROPERTY DAMAGE.

DESCRIPTION

This multi-function gas controls combines into a single compact package the functions of 3-position gas cock, a main gas valve and a pressure regulator. The pilot outlet is plugged, but will accept a $\frac{1}{4}$ " pilot line connection. This control can be mounted in any orientation except upside down.

To permit replacement of a variety of valve sizes, this control is furnished with three reducer bushings (two $\frac{3}{4}$ " to $\frac{1}{2}$ " and one $\frac{1}{2}$ " to $\frac{3}{8}$ "). Also included is a conversion kit which allows this valve to be used at regulator settings of 4.2" W.C. to 11.0" W.C.

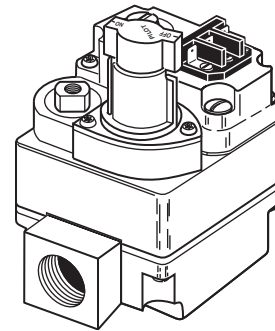

MODELS AVAILABLE

Model No.	Voltage	Gas	Current
36C01	24 volts	Nat.	.23 Amp
36C01A	120 volts	Nat.	.035 Amp

SPECIFICATIONS

Electrical Rating:

24 VAC, 60 Hz., 23A

Pilot Gas Outlet:

Located at outlet end of the valve

Type of Gas:

Suitable for all domestic heating gases

Pressure Regulator Setting:

Adjustable from 2 $\frac{1}{2}$ to 5" W.C. (Factory adjusted for 3.5" W.C.)

Pressure Rating:

$\frac{1}{2}$ lb. per sq. in.

Ambient Temperature:

-40° to 175°F

Mounting:

Any position except upside-down

	CAPACITY (IN BTU PER HOUR)	
	NATURAL GAS (1000 Btu/Cu. Ft. 0.64 Sp. Gr.)	LP GAS (2500 Btu/Cu. Ft. 1.53 Sp. Gr.)
$\frac{1}{2}$ " x $\frac{3}{8}$ "	100,000	162,000
$\frac{1}{2}$ " x $\frac{1}{2}$ "	230,000	372,600
$\frac{1}{2}$ " x $\frac{3}{4}$ "	230,000	372,600
$\frac{3}{4}$ " x $\frac{3}{4}$ "	280,000	453,600

Upright, 90° from upright or vertical

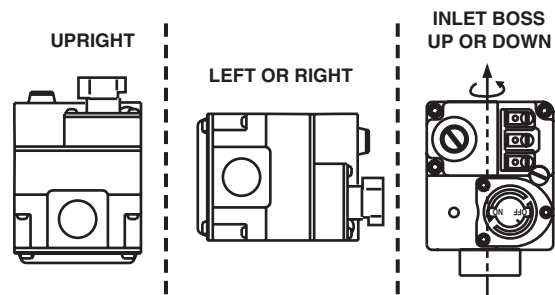

NOTE: Control shown may not be identical to replacement control.

PRECAUTIONS

DO NOT BEGIN INSTALLATION UNTIL YOU READ THE FOLLOWING PRECAUTIONS.

⚠ WARNING



If you do not follow these instructions exactly, a fire or explosion may result, causing property damage, personal injury or loss of life.

1. Failure to turn off electric or main gas supply to heating system could cause personal injury and/or property damage by shock, gas suffocation, fire, and/or explosion.
2. Do not use this control on circuits exceeding specified voltage. Higher voltage will damage the control and may cause shock or fire hazard.
3. NEVER USE FLAME OR ANY KIND OF SPARK TO CHECK FOR GAS LEAKS—COULD CAUSE FIRE AND/OR EXPLOSION.
4. DO NOT USE WIRE JUMPER on pilot systems, such as standing pilot, proven pilot, or spark-to-pilot ignition—a fire and/or explosion may result.
5. Do not use a control set for natural gas with LP gas, or a control set for LP gas with natural gas. Personal injury and/or property damage, gas suffocation, fire, and/or explosion may result.

⚠ CAUTION

1. Do not short out terminals on gas valve or primary control to test. Short or incorrect wiring can cause equipment damage, property damage, and/or personal injury.
2. This control is not intended for use in locations where it may come in direct contact with water. Suitable protection must be provided to shield the control from exposure to water (dripping, spraying, rain, etc.).

INSTALLATION

MAIN PIPING CONNECTIONS

NOTE

All piping must comply with local codes, ordinances, and/or national fuel gas codes.

1. Turn off electrical power to the system at the fuse box or circuit breaker. Also turn off the main gas supply.
2. If replacing an existing valve, disconnect all plumbing and electrical connections from the old control.
3. The control may be installed in any orientation **except upside down**. The arrow on the valve indicates the direction of gas flow through the control.
4. You should use new pipe that is properly chamfered, reamed, and free of burrs and chips. If you are using old pipe, be sure it is clean and free of rust, scale, burrs, chips, and old pipe joint compound.
5. Apply pipe joint compound (pipe dope) or teflon tape that is approved for all gases, only to the male threads of the pipe joints. DO NOT apply compound or teflon tape to the first two threads (see fig. 1 for typical piping connections).
6. If you are using a vise or open-end wrench to hold the valve while installing piping, do not tighten excessively, as this may damage the valve.
7. If additional clearance for the gas cock knob is required when installing the new valve in an existing system, rotate the knob to the position between ON and OFF. Depress the knob while turning the valve. The knob will depress only while in this position.
8. See **SYSTEM WIRING** when making electrical connections. After all gas and electrical connections are completed, turn gas on and check for gas leaks with leak detection solution or soap suds. Bubbles forming indicate a leak. **SHUT OFF GAS AND FIX ALL LEAKS IMMEDIATELY.**

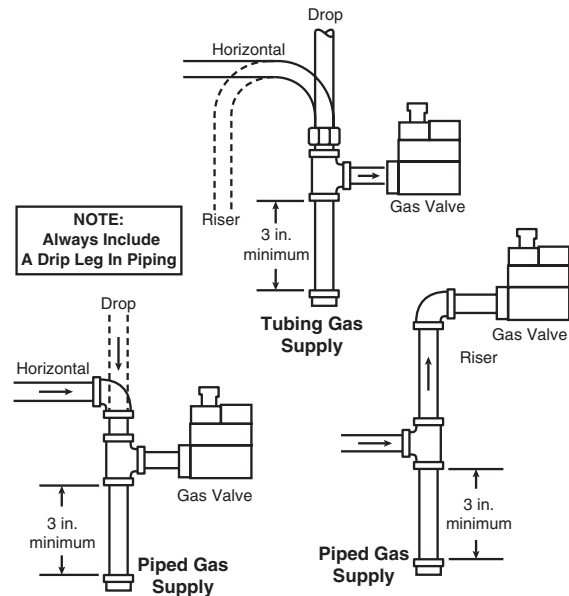

Figure 1. Typical gas valve piping

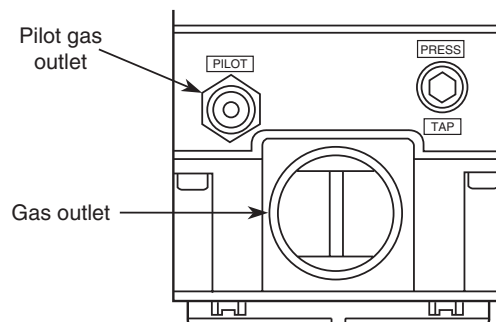

Figure 2. Gas valve side view

PILOT GAS CONNECTION

Install fitting into pilot gas outlet (see fig. 2), turning until finger-tight. Insert clean, deburred tubing all the way through the fitting. While holding the tubing securely, slowly tighten fitting until you feel a slight “give”. Tighten the fitting an additional 1½ turns.

SYSTEM WIRING

⚠ CAUTION

To prevent electrical shock and/or equipment damage, disconnect electrical power to system at main fuse or circuit breaker box until installation is complete.

NOTE

All wiring should be installed in accordance with local and national electrical codes and ordinances.

Always check that the electrical power supply used agrees with the voltage and frequency shown on the gas control.

The typical wiring diagrams (figs. 3 & 4) show only the terminal identification and/or wiring hook up. Always refer to wiring instructions provided by Equipment Manufacturer for system hookup operation.

PILOT GAS ADJUSTMENT

If the pilot flame is low and does not engulf the bulb of the mercury flame sensor, the system will not energize the main valve. If pilot gas pressure is too high, gas will sputter past the ignition electrode, and may not ignite. High pilot gas pressure may also cause the flame to lift off the burner, causing the flame sensor bulb to sense “low” heat.

To adjust the pilot gas pressure, remove the cover screw (see fig. 5). **To REDUCE pilot pressure**, turn the pilot adjust screw (beneath the cover screw) clockwise. **To INCREASE pilot pressure**, turn the pilot adjust screw counterclockwise. Replace and tighten cover screw.

PRESSURE REGULATOR ADJUSTMENT

The pressure regulator has been factory adjusted (see control for specific setting). Although additional adjustments will not normally be necessary, you may adjust the regulator. **Do not force the adjusting screw beyond the limits that it can easily be adjusted.**

1. Energize valve to ignite main burner.
2. Remove “Reg. Adj.” cover screw (see fig. 6).
3. **To DECREASE outlet pressure**, turn the adjusting screw (beneath the cover screw) counterclockwise.
To INCREASE outlet pressure, turn the adjusting screw clockwise.
4. Replace the cover screw. Cycle the valve two or three times to verify regulator setting.

NOTE

If adjustment to higher range (4.2” W.C. to 11.0” W.C.) is required, use conversion kit packed with control.

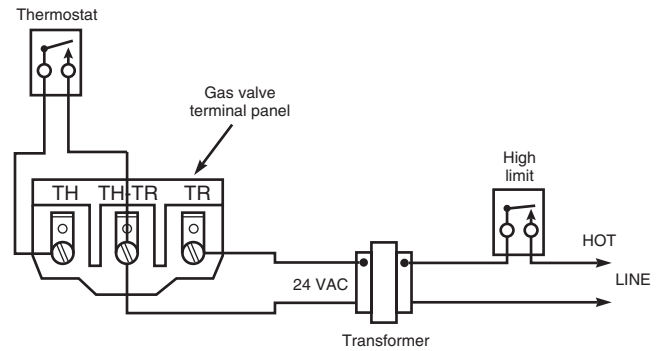

Figure 3. Wiring for 36C01 (24 Volt)

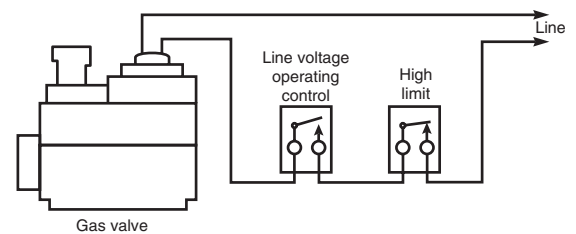

Figure 4. Wiring for 36C01A (120 Volt)

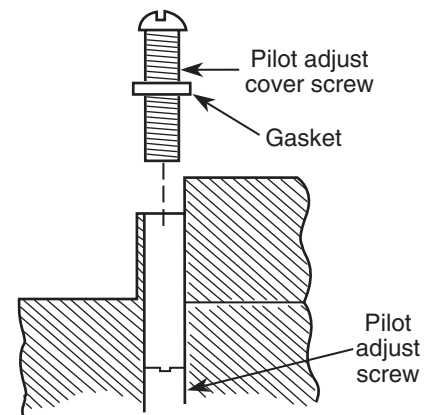

Figure 5. Pilot gas adjustment

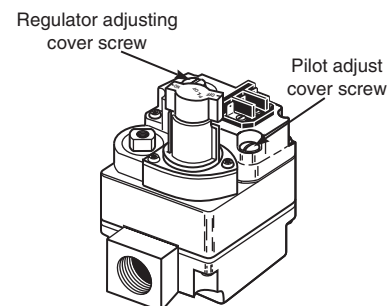

Figure 6. Pressure regulator adjustment

PILOT LIGHTING INSTRUCTIONS AND PRECAUTIONS

FOR YOUR SAFETY READ BEFORE LIGHTING

▲ WARNING



If you do not follow these instructions exactly, a fire or explosion may result causing property damage, personal injury or loss of life.

- A. This appliance has a pilot that must be lighted by hand. When lighting the pilot, follow these instructions exactly.
 - B. **BEFORE LIGHTING**, smell all around the appliance area for gas. Be sure to smell next to the floor because some gas is heavier than air and will settle on the floor.
- **Immediately call your gas supplier from a neighbor's phone. Follow the gas supplier's instructions.**
 - **If you cannot reach your gas supplier, call the fire department.**
- C. Use only your hand to push in or turn the gas control knob. **Never use tools.** If the knob will not push in or turn by hand, don't try to repair it; call a qualified service technician. Force or attempted repair may result in a fire or explosion.
 - D. Do not use this appliance if any part has been under water. Immediately call a qualified service technician to inspect the appliance and to replace any part of the control system and any gas control that has been under water.

FOR YOUR SAFETY "WHAT TO DO IF YOU SMELL GAS"

- **Do not try to light any appliance.**
- **Do not touch any electrical switch; do not use any phone in your building.**

LIGHTING INSTRUCTIONS

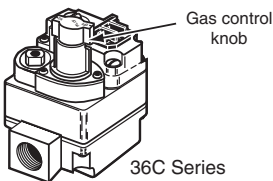
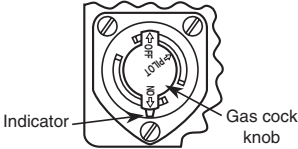
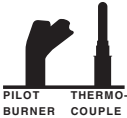
1. **STOP!** Read the precautionary information above.
 2. Set the thermostat to lowest setting.
 3. Turn off all electrical power to the appliance.
 4. Depress gas control knob slightly and turn clockwise to **OFF** (see fig. 6). If knob is in **ON**, turn clockwise to **PILOT**, then depress knob slightly and turn clockwise to **OFF**.
- 
- 
- 
6. Remove the pilot access panel(s) located under the gas control unit.
 7. Find pilot - follow small metal tubes from gas control.
 8. Turn knob on gas control counterclockwise to **PILOT**.
 9. Depress control knob all the way and hold in. **Immediately** light the pilot with a match. Continue to hold the control knob down for about one (1) minute after the pilot is lit. Release knob and it will pop back up. Pilot should remain lit. If it goes out, repeat steps 4, 5, 8, and 9.
 - If knob does not pop up when released, turn clockwise to **OFF**, stop and immediately call your service technician or gas supplier.
 - If the pilot will not stay lit after several tries, turn the gas control knob to **OFF** and call your service technician or gas supplier.
 10. Replace pilot access panel(s).
 11. Turn gas control knob counterclockwise to **ON**.
 12. Turn on all electrical power to the appliance.
 13. Set thermostat to desired setting.

NOTE: Knob cannot be turned from **PILOT** to **OFF** unless knob is depressed slightly. Do not use tools or excessive force.

5. Wait fifteen (15) minutes to clear out any gas. If you then smell gas, **STOP!** Follow **B** in the precautionary information above. If you don't smell gas, go to next step.

TO TURN OFF GAS TO APPLIANCE

1. Set the thermostat to lowest setting.
2. Turn off all electrical power to the appliance if service is to be performed.
3. Turn gas control knob clockwise to **PILOT**.
4. Depress gas control knob slightly and turn clockwise to **OFF**. **Do not use tools or excessive force.**

White-Rodgers is a business of Emerson Electric Co.

The Emerson logo is a trademark and service mark of Emerson Electric Co.

White
Rodgers™

www.white-rodgers.com
www.emersonclimate.com



EMERSON
Climate Technologies