

# YP7899A1002 - 7800 SERIES Burner Management and Fuel Air Ratio Control Panel - Single Fuel

## INSTALLATION INSTRUCTIONS



- 65-0239, ML7999A Universal Parallel-Positioning Actuator
- 65-0321, S7999D1048 System Display
- 66-1152, RM7800L1087 Relay Module with Valve Proving
- 65-0029, 7800 Series Relay Module Checkout and Test
- 65-0084, Q7800A 7800 SERIES 22-Terminals Universal Wiring Subbase
- 66-2034, R78xx Amplifiers for 7800 SERIES and R7140 Relay Modules
- 65-0089, ST7800A,C 7800 SERIES Plug-In Purge Timer
- 65-0249, S7810M Modbus Module
- 60-2026, C7027, C7035, C7044, C7927 Minipeeper UV Flame Detector
- 65-0267, C7961 Dynamic Self-checking Solid State UV Flame Detector
- 60-0292, C7915 Infrared Flame Detector
- 65-0277, C7962 Visible Light Flame Detector
- 60-2024, C7007, C7008, C7009 Flame Rod Detector
- 95-8269, C7076 Adjustable Sensitivity UV Flame Detector
- 60-2398, C7012 Ultraviolet Flame Detectors

## APPLICATION

The 7800 SERIES Burner Management and Fuel Air Ratio Control Panel is a packaged, pre-wired panel that includes the RM7800L1087 burner control, the R7999A ControLinks fuel air ratio control and a Modbus® interface. The included S7999D color touchscreen interface allows commissioning of the ControLinks system as well as monitoring and control of it and the RM7800 control, all with user-friendly menus. On board switches, buttons and alarm lights are included for customer convenience. The ML7999A2001 universal direct coupled actuators are purchased separately as well as the burner control purge card, amplifier and flame detector.

This document provides installation instructions and operation information. Other applicable publications are:

- 65-0238, R7999 ControLinks Controller
- 65-0240, Q7999A ControLinks Universal Wiring Subbase
- 65-0288, S7800A1142 Keyboard Display Module 7800 SERIES

## FEATURES

- **Pre-wired and ready to install**
- **Includes the RM7800L1087 burner control with wiring subbase, S7810M modbus module, R7999 fuel air ratio control with wiring subbase and S7999D touchscreen display**
- **Commission, monitor and control ControLinks through the touchscreen interface**
- **Fuel selector switch**
- **Burner on/off selector switch**
- **Alarm lights**
- **Reset buttons**
- **Unit shutdown / Emergency stop button**
- **Auto/manual switch**
- **Manual operation potentiometer**
- **S7999D touchscreen display is modbus ready**
- **VPS (Valve Proving System) capability via flame safeguard control**



## SPECIFICATIONS

### Electrical Ratings

120 Vac, 50/60 Hz, 10 Amps

For individual ratings, see component literature for details.

### Environmental Ratings

Enclosure: NEMA 12.

For individual ratings, see component literature for details.

### Humidity

Install the panel where the relative humidity never reaches the saturation point. The relay module inside the panel is designed to operate in a maximum 85 percent relative humidity continuous, non-condensing, moisture environment.

### Vibration

Do not install the panel where it could be subjected to vibration in excess of 0.5G continuous maximum vibration.

### General

Overall panel size: 30in. high x 24 in. wide x 8 in. deep (excluding door and door mounted components)

Panel weight: approx. 91 pounds

Mounting holes are 0.44 in. typical diameter, 18 in. on center.

### Approvals

Components are individually approved by the nationally recognized agencies. Please see component literature for details. The panel has UL 508A approval. Panel is assembled and wired to the UL Standards.

## INSTALLATION

### When Installing This Product...

1. Read these instructions and the appropriate product literature carefully. Failure to follow them could damage the product or cause a hazardous condition.
2. Refer to the installation manuals and wiring diagrams provided with this panel for the embedded products.
3. Check the ratings given in the instructions and on the product to make sure that the product is suitable for your application.
4. Installer must be a trained, experienced combustion service technician.
5. Disconnect the power supply before beginning installation to prevent electrical shock and equipment damage. More than one disconnect may be involved.
6. All wiring must comply with the National Electric Code (NEC) and any applicable local electrical codes, ordinances and regulations.
7. After installation is complete, check out product operation as provided in the appropriate product installation instructions.

## WARNING

**Fire or Explosion Hazard. Can cause severe injury, death or property damage.**

To prevent possible hazardous burner operation, verify safety requirements each time a controller is installed on a burner.

## WIRING

## WARNING

**Electrical Shock Hazard. Can cause serious injury, death or equipment damage.**

Disconnect the power supply before beginning wiring to prevent electrical shock, equipment and control damage. More than one disconnect may be involved.

## Ground Connection

Earth ground is required for proper operation of the panel and components. The earth ground must be capable of conducting enough current to blow the fuse or breaker in the event of an internal short. Ensure the panel is bonded to a substantial earth ground. Make sure that mechanically tightened joints along the ground path are free of nonconductive coatings and protected against corrosion on mating surfaces.

## Electrical Connections

1. Refer to the appropriate product data sheet for details.
2. Wire size and length will vary, depending on the component. Refer to the component literature for specific wire lengths, sizes and type recommendations.
3. Wire according to specifications, following all local ordinances and requirements.
4. Field knockouts are required for the wiring. When drilling holes, take care to protect the electronics from metal pieces and debris.

### **IMPORTANT**

*Run line voltage and low voltage wiring in separate conduit to avoid signal interference.*

*Carefully check field wiring and terminal designations in this document and the associated wiring diagram. They are different from those of the individual components.*

## Panel Inspection

After mounting and wiring, but before powering the panel, inspect all internal panel wire connections. Each panel is fully tested at the factory, however, wires may loosen during transit. Verify that all internal wire connections are secure from the Q7999 and Q7800 subbases to the components mounted on the door and the S7999D touchscreen interface.

## Final Wiring Check and Static Checkout

All wiring shall be in accordance with the National Electric Codes (NEC) and local electrical codes.

1. Check the power supply circuit. The voltage and frequency must match the specification listed.
2. Check wiring terminations and routing to ensure proper connections.
3. Follow any system checkout recommendations for individual components as found in the component literature.
4. Restore power to the panel.



### CAUTION

Test each limit and interlock to ensure system operates correctly as defined in the 7800 Series "Checkout and Test" document (Form #65-0229).



### WARNING

**Explosion and Electrical Shock Hazard.  
Can cause serious injury, death or equipment damage.**

1. *Close all manual fuel shutoff valves before starting these tests.*
2. *Use extreme care while testing the system. Line voltage is present on most terminal connections when power is on.*
3. *Replace all limits and interlocks that are not operating properly. Do not bypass limit and interlocks.*

# TROUBLESHOOTING

## System Diagnostics

The S7999D touchscreen interface indicates the current fault and keeps a fault history log. The R7999 ControlLinks control, the ML7999A Universal Parallel-Positioning Actuator and the

RM7800L control also have LED fault blink codes. Refer to the appropriate product instruction sheet for further troubleshooting information and diagnostic codes.

## Field Wiring

**Table 1. Field Wiring and Terminal Designation.<sup>1</sup>**

Terminal #	To Connecting Device	Description
1 <sup>2</sup>	L1 Panel Power	<b>120Vac Power Supply, 10A Max.</b> Provide disconnect means and overload protection as required.
2	L2 Panel Neutral	
GND	Panel Ground	
4	L1	L1 customer convenience wire point - provided for 4 actuators - 120Vac, 50/60Hz
2	L2	L2 customer convenience wire point - provided for 4 actuators
GND	Panel Ground	GND customer convenience wire point - provided for 4 actuators
27-5 <sup>3</sup>	Airflow Switch	Combustion airflow (pressure) switch
5-6 <sup>3</sup>	LP Switch	Fuel low pressure/temperature switch
6-7 <sup>3</sup>	HP Switch	Fuel high pressure/temperature switch
7-8 <sup>3</sup>	Interlocks	Fuel customer interlocks and limits, including LWCO, high-limit, etc.
8-9 <sup>3</sup>	High Limit	High limit device
10	Blower Motor	Combustion blower motor line voltage output from burner control
14 <sup>4</sup>	Shutter Drive	Shutter drive output connection from burner control
16 <sup>4</sup>	F	Flame detector F lead connection from burner control
GND <sup>4</sup>	Panel Ground	Flame detector G lead connection from burner control
25-28	Burner Control	On/off burner operating control
XF-2 <sup>5</sup>	Ignition	Spark ignition transformer
4-19 <sup>3</sup>	POC Switch 1	Main fuel valve 1 proof of closure switch (pre-ignition interlock switch)
19-20 <sup>3</sup>	POC Switch 2	Main fuel valve 2 proof of closure switch (pre-ignition interlock switch)
17-2	Pilot Valve(s)	Pilot fuel valve(s) connection to burner control output - 10 second interrupted pilot
18-2 <sup>6</sup>	Main Valve(s)	Main fuel valve(s) connection to burner control output
202 <sup>7,8</sup>	DR1	Air Actuator DR1 command input
203 <sup>7,8</sup>	DR2	Air Actuator DR2 command input
204 <sup>7,8</sup>	CW	Air Actuator potentiometer CW output
205 <sup>7,8</sup>	S	Air Actuator potentiometer S output
206 <sup>7,8</sup>	CCW	Air Actuator potentiometer CCW output
GND <sup>7,8</sup>	Ground	Air Actuator ground
207 <sup>7,8</sup>	DR1	Fuel 1 Actuator DR1 command input
208 <sup>7,8</sup>	DR2	Fuel 1 Actuator DR2 command input
209 <sup>7,8</sup>	CW	Fuel 1 Actuator potentiometer CW output
210 <sup>7,8</sup>	S	Fuel 1 Actuator potentiometer S output
211 <sup>7,8</sup>	CCW	Fuel 1 Actuator potentiometer CCW output

**Table 1. Field Wiring and Terminal Designation.<sup>1</sup> (Continued)**

Terminal #	To Connecting Device	Description
GND <sup>7,8</sup>	Ground	Fuel 1 Actuator ground
214 <sup>7,8</sup>	DR1	FGR/4th Channel Actuator DR1 command input
215 <sup>7,8</sup>	DR2	FGR/4th Channel Actuator DR2 command input
216 <sup>7,8</sup>	CW	FGR/4th Channel Actuator potentiometer CW output
217 <sup>7,8</sup>	S	FGR/4th Channel Actuator potentiometer S output
218 <sup>7,8</sup>	CCW	FGR/4th Channel Actuator potentiometer CCW output
GND <sup>7,8</sup>	Ground	FGR/4th Channel Actuator ground
220	XmA+	Auxiliary 4-20mA+ input from Stack/Water temperature sensor (used for low fire hold)
212	XmA-	Auxiliary 4-20mA- input from Stack/Water temperature sensor (used for low fire hold)
221	CmA+	4-20mA+ input from Firing Rate control
222	CmA-	4-20mA- input from Firing Rate control
228 <sup>9</sup>	COM 2 A	S7999D COM 2 modbus A / Data + terminal
229 <sup>9</sup>	COM 2 B	S7999D COM 2 modbus B / Data - terminal
225 <sup>9</sup>	COM 2 GND	S7999D COM 2 Modbus C / Ground terminal

<sup>1</sup>Carefully check field wiring and terminal designations in this document and the associated wiring diagram. They are different from those of the individual components.

<sup>2</sup>The circuit protection incorporated into this control panel is designed to serve as supplemental protection only. It is the responsibility of the end user to provide appropriate protection on the service to this control panel. Refer to the National Electric Code and UL standard 1077 for more information on this subject.

<sup>3</sup>Jumper all unused limits and interlocks.

<sup>4</sup>Refer to the appropriate flame detector product sheet for wiring size and length information. Run flame detector F and G leads in their own conduit, independent of other power carrying leadwires. Flame detector power and shutter wires (if applicable) must be run in their own conduit as well, avoiding other electrical noise carrying wiring. The scanner wires should remain separated a minimum of 2 inches from other line voltage wires in the control panel to the flame safeguard device.

<sup>5</sup>Refer to the appropriate ignition transformer product sheet for wiring size and length information. Separate the high voltage ignition cable from other wires to avoid interference. Ignition cable to the spark electrode must be run in separate conduit (if applicable).

<sup>6</sup>If VPS (Valve Proving System) usage is required with the RM7800 burner control, contact factory for advice regarding wiring.

<sup>7</sup>Low voltage wire to the firing rate actuators must be run in separate conduit. Line voltage wiring to actuators provided by customer. Run line voltage wires in separate conduit. Refer to the ML7999A product sheet for details.

<sup>8</sup>Connect the shield ground of the ML7999A actuator(s) to the earth ground strip provided in the Q7999 universal subbase, on the low voltage side. Connect the shield at the controller end only. Refer to the ML7999A product sheet for details.

<sup>9</sup>COM 2 on the S7999D is wired to the S7810M Modbus module on the RM7800L burner control. Customer may wire Modbus-enabled UDC2500/3200/3500 controls in a daisy-chain fashion to the customer terminals provided for display on the S7999D. Refer to the S7999D and UDC control product manuals for further information on wiring and S7999D display set-up.

<sup>10</sup>Installation, operation and maintenance shall conform with National Fire Protection Association standards, national and local codes and authorities having jurisdiction.

<sup>11</sup>For detailed device wiring information, refer to the RM7800, Q7999, R7999, Q7999A, ML7999A and S7999D1048 product sheets.

<sup>12</sup>Spare/unused terminals are provided for customer field use.

Fig. 1.

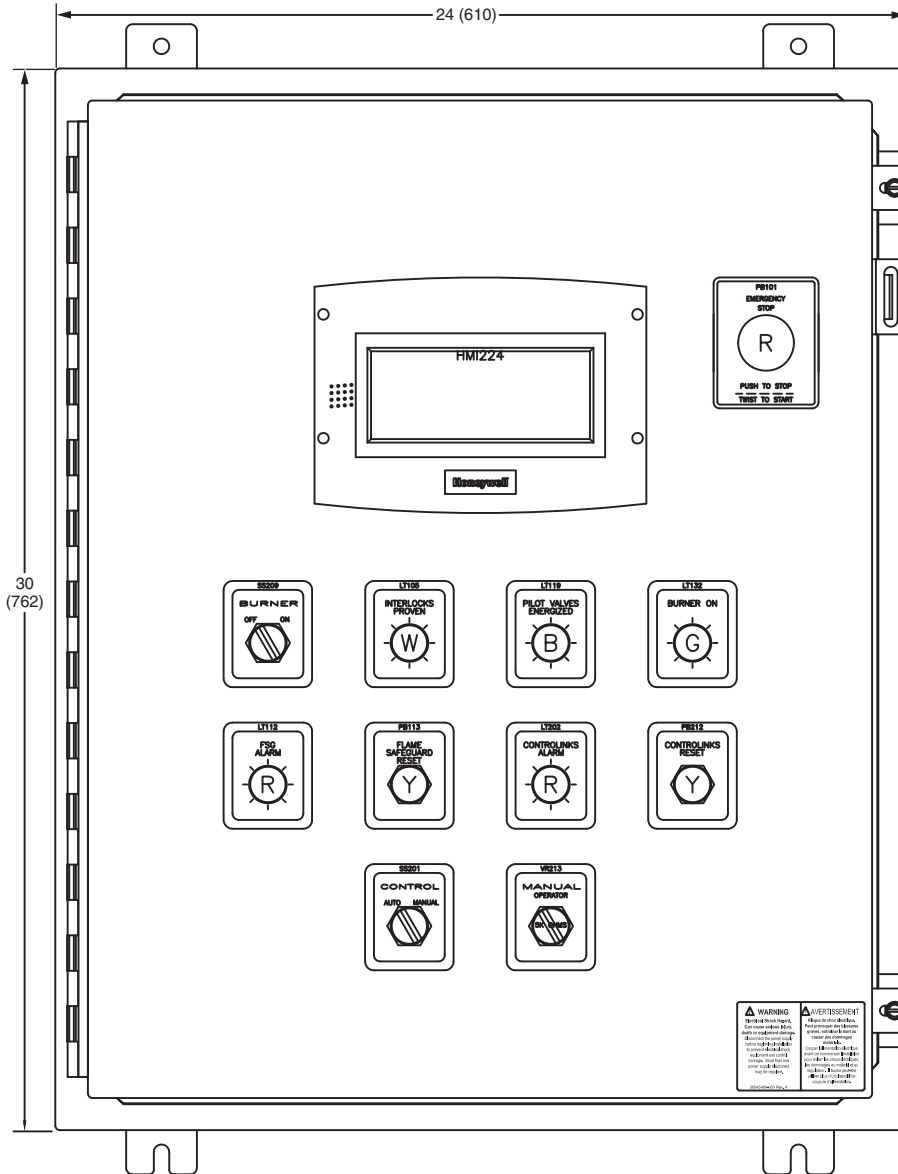

NOTES:

1. THE CIRCUIT PROTECTION INCORPORATED INTO THIS CONTROL PANEL IS DESIGNED TO SERVE AS SUPPLEMENTAL PROTECTION ONLY. IT IS THE RESPONSIBILITY OF THE END USER TO PROVIDE APPROPRIATE PROTECTION ON THE SERVICE TO THIS CONTROL PANEL. REFER TO THE NATIONAL ELECTRIC CODE AND UL STANDARD 1077 FOR MORE INFORMATION ON THIS SUBJECT.
2. JUMPER ALL UNUSED LIMITS AND INTERLOCKS.
3. THE USE OF A HIGH TEMPERATURE LIMIT IS STRONGLY RECOMMENDED ON ALL APPLICATIONS. THIS DEVICE IS TO BE SUPPLIED BY THE CUSTOMER, IN THE FIELD. IF AFTER CAREFUL REVIEW OF YOUR APPLICATION (BY QUALIFIED PERSONNEL) IT IS DETERMINED THIS DEVICE IS NOT REQUIRED, THEN IT MAY BE OMITTED.
4. FIELD WIRING SHOWN FOR BLOCK AND BLEED VALVE ARRANGEMENT.
5. FIELD WIRE TO THE DETECTOR SHOULD BE #14 AWG, TYPE TW 600V INSULATED WIRE OR EQUAL. WIRE MUST NOT BE IN THE SAME CONDUIT WITH POWER WIRING.
6. IGNITION CABLE TO THE SPARK ELECTRODE MUST BE RUN IN SEPARATE CONDUIT. (IF APPLICABLE)
7. WIRE TO THE FIRING RATE ACTUATOR MUST BE RUN IN SEPARATE CONDUIT.
8. INSTALLATION, OPERATION AND MAINTENANCE SHALL CONFORM WITH NATIONAL FIRE PROTECTION ASSOCIATION STANDARDS, NATIONAL AND LOCAL CODES, AND AUTHORITIES HAVING JURISDICTION.

- INDICATES TERMINALS AND WIRING IN MAXON CONTROL PANEL. (MAIN TERMINAL BLOCK).
- INDICATES EXTERNAL WIRING
- △ INDICATES TERMINALS IN MAXON VALVES
- INDICATES COMPONENT TERMINALS

WIRE CODE		
FUNCTION	COLOR	AWG
220VAC (HOT)	BLACK	16 (MTW)
220 VAC (NEUTRAL)	WHITE	16 (MTW)
120 VAC (HOT)	RED	16 (MTW)
120 VAC (NEUTRAL)	WHITE	16 (MTW)
EXTERNAL POWER SOURCE	YELLOW	16 (MTW)
DRY CONTACTS	YELLOW	16 (MTW)
VDC	BLUE	16 (MTW)
24 VAC	BROWN	16 (MTW)
4-20mA SIGNAL	BLUE	16 (MTW)
TYPE J THERMOCOUPLE	WHITE/RED	20 (POLYVINYL)
TYPE K THERMOCOUPLE	YELLOW/RED	20 (POLYVINYL)
FSG RESETS/DISPLAY/CONTROL BUS	BELDON	22 (AWG) TWISTED PAIR
GROUND	GREEN	14 (MTW)

M34546

Fig. 2 - Part 1.

120/1/60  
USE 16 AWG MTW WIRE

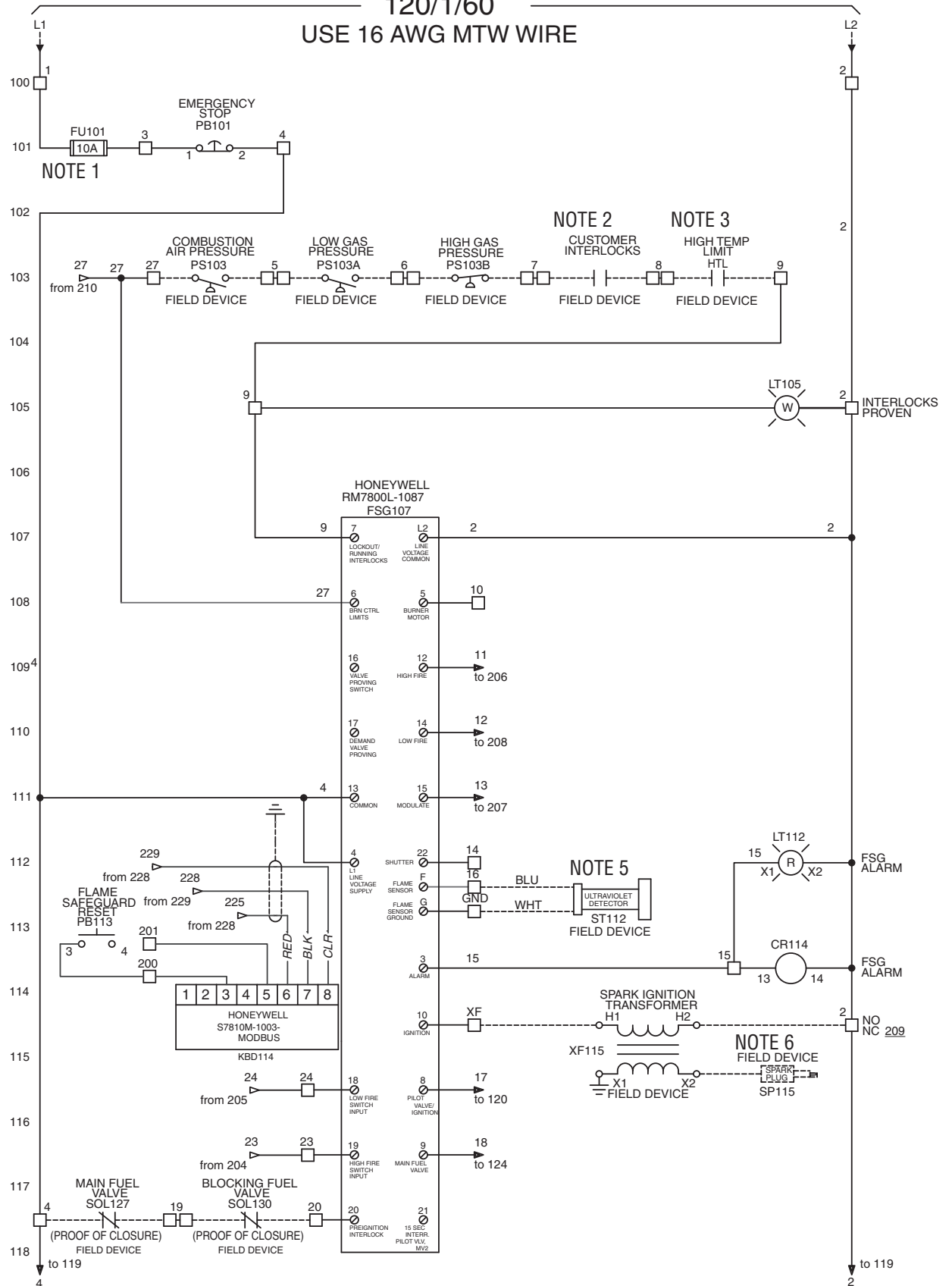

1124734-ECC

M34544

Fig. 2 - Part 2.

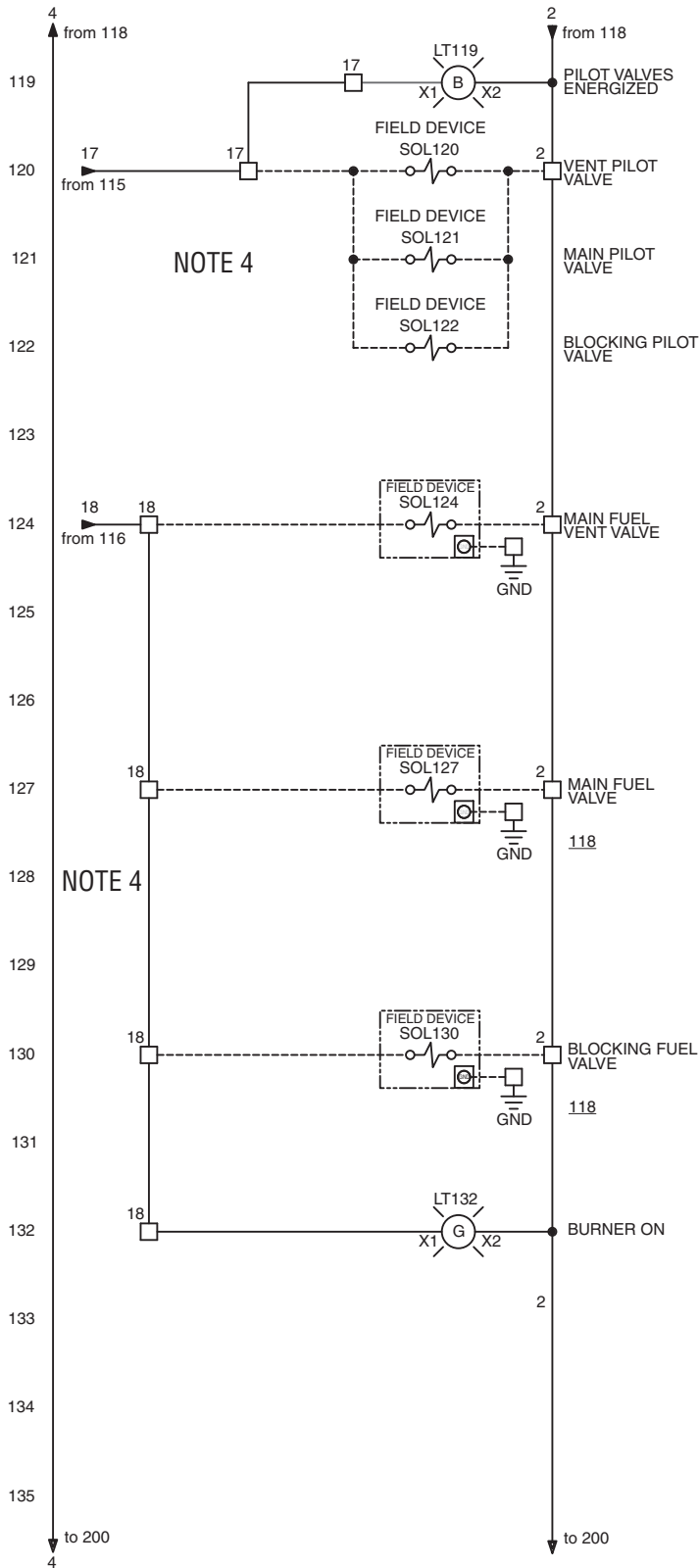

M34657



Fig. 3 - Part 1.

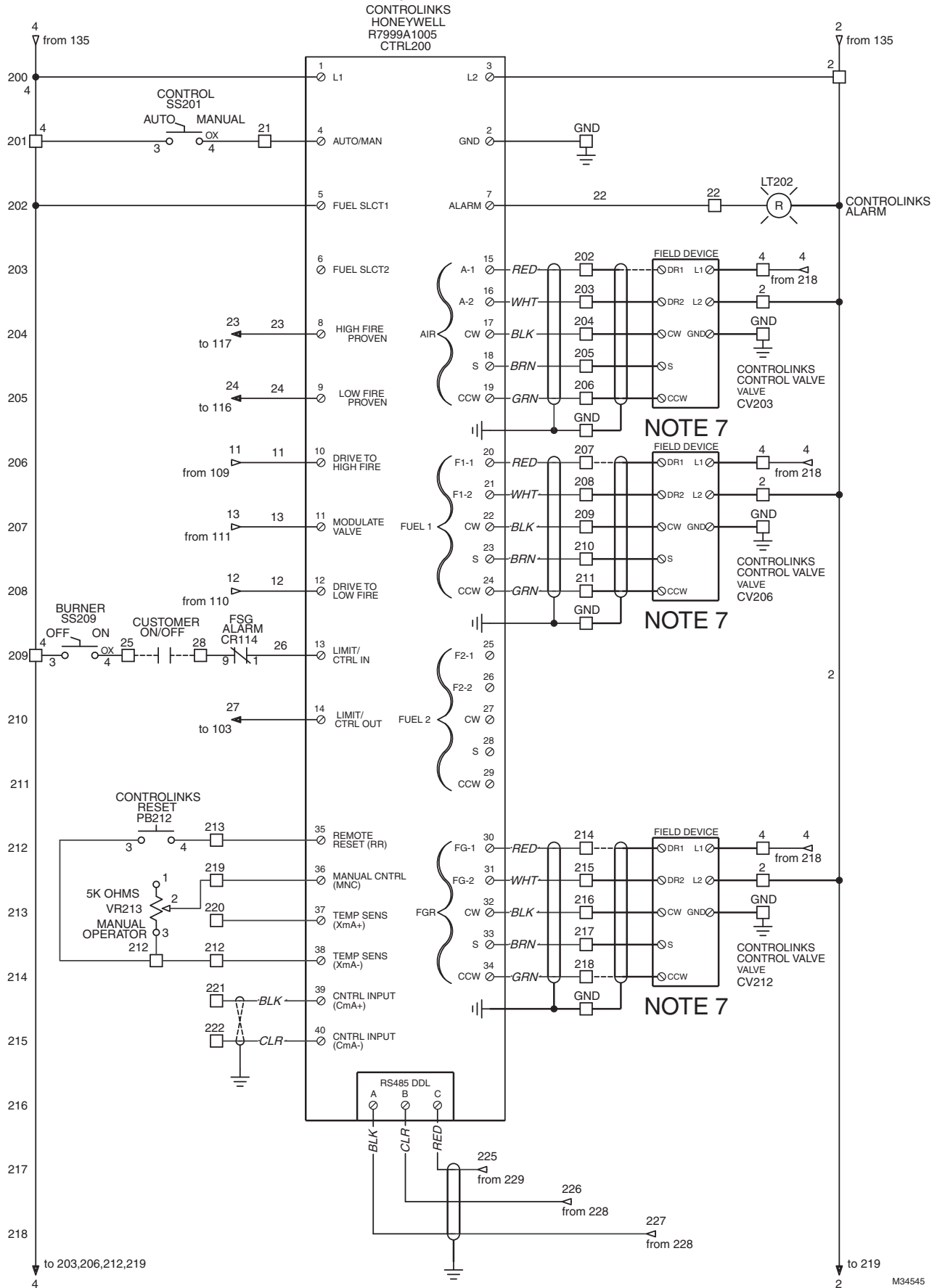
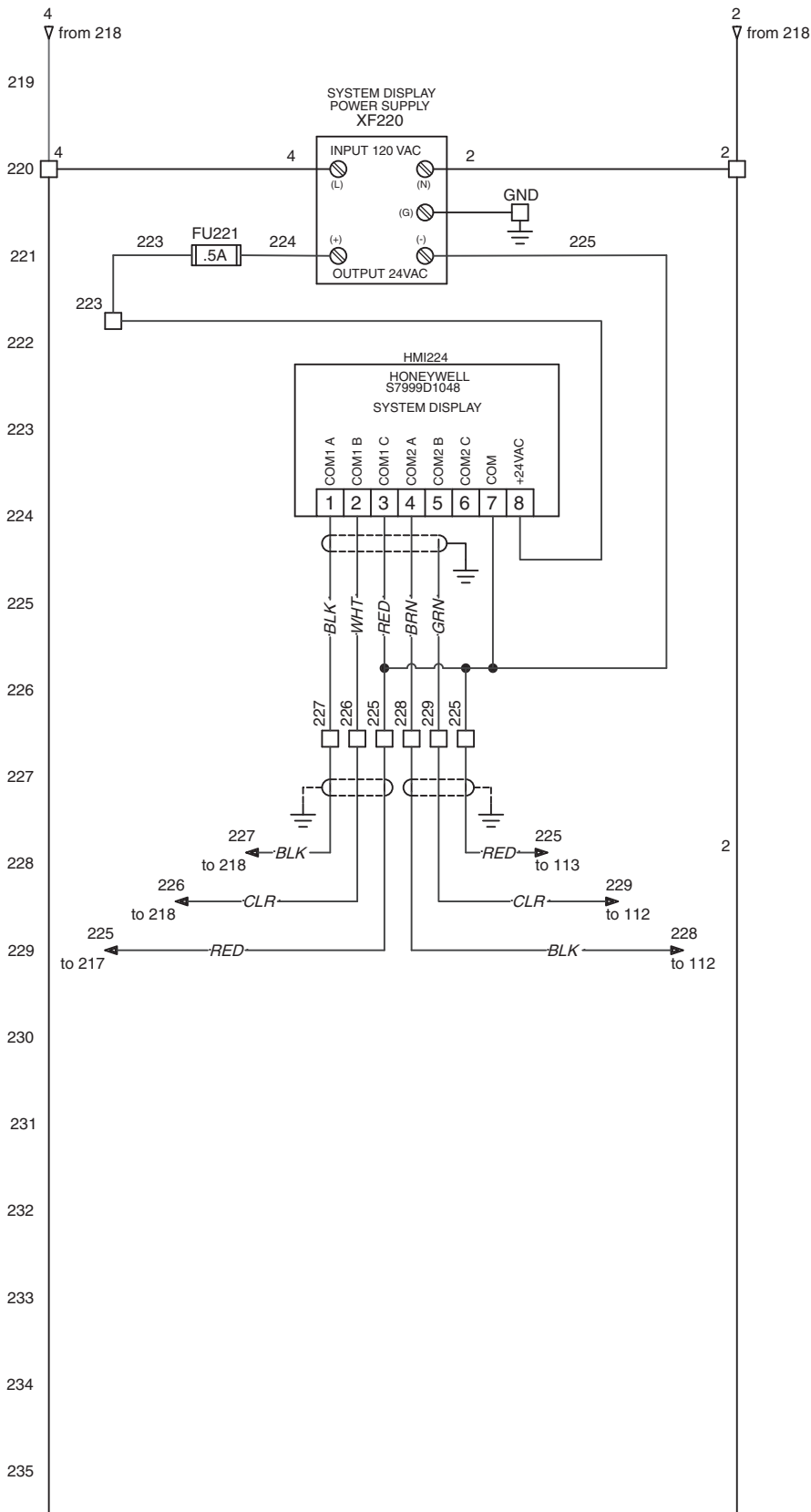
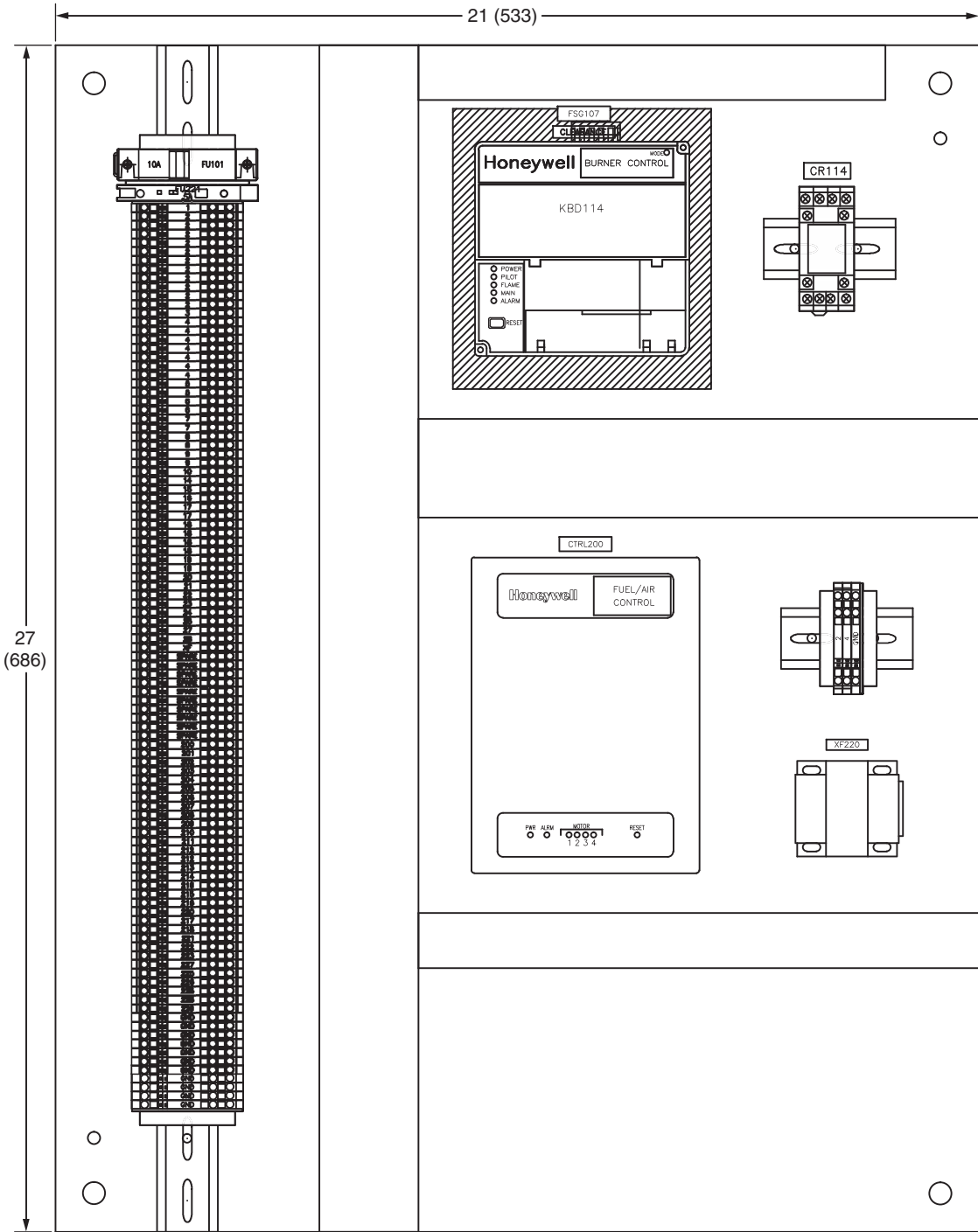

Fig. 3 - Part 2.



M34658

Fig 4.



M34547

**Automation and Control Solutions**

Honeywell International Inc.  
1985 Douglas Drive North  
Golden Valley, MN 55422  
[customer.honeywell.com](http://customer.honeywell.com)

© U.S. Registered Trademark  
© 2013 Honeywell International Inc.  
66-2062—01 M.S. 03-13  
Printed in United States

**Honeywell**